

# SL SERIES POWER DISTRIBUTION MODULES



## Description

High-amp circuits can be disconnected with remote switch SL PDM (PN 880075) or manual/remote switch SL PDM (PN 880076). SL PDM designed to disconnect high-amp circuits remotely through the use of a remote switch. 880076 can be disconnect through the use of switch on unit. Ideal for low-amp “always on” loads including clock memory, alarms, tachograph, and telematics (e.g. Qualcomm) modules; and for high-amp circuits such as vehicle control modules, inverters, and auxiliary circuits.

Ignition protected to SAE J1171 and ISO 8846 for installation in a battery box, or on vehicles carrying hazardous loads. Water and dust-resistant to IP59K, permitting high temperature, high-pressure washing. Provides the benefits of a sealed cover, but allows water to escape if the cover is mistakenly unsecured. Tin-plated copper studs provide maximum conductivity and significantly lower contact resistance. Stainless steel hardware provides superior corrosion resistance. Also available with pre-installed fuses to customer needs.

These products are customer-limited. Please consult Littelfuse for details. Fuses sold separately.

## Features and Benefits

- Provides main battery shutdown from a remote location.
- Optional manual control knob switches high-amp circuits.
- Three switched 30A to 200A MIDI® fuse locations.
- Four unswitched 24-hour 1A-20A ATO® fuse locations.
- Eliminates significant factory or field interconnections.

## Internal Battery Switch Specifications

|                                    |                               |
|------------------------------------|-------------------------------|
| <b>Continuous Amperage Rating:</b> | 300A at 85°C<br>240A at 105°C |
| <b>Cranking Rating:</b>            | 10 sec. 1,000A                |

## MIDI® Fuse Block Specifications

|  |                               |
|--|-------------------------------|
| <b>Amperage Maximum Operating (per block):</b>   | 240A                          |
| <b>Amperage Maximum Operating (per circuit):</b> | 170A                          |
| <b>Fuse Amperages Available:</b>                 | 30A–200A                      |
| <b>Minimum Cable Size to Meet Ratings:</b>       | 2/0 AWG (70 mm <sup>2</sup> ) |
| <b>Screw Size:</b>                               | M5 x .8 x 10                  |
| <b>Screw Torque:</b>                             | 27 in-lb (3.0 N-m)            |

## ATO® Fuse Block Specifications

|  |        |
|--|--------|
| <b>Amperage Maximum Operating (per block):</b>   | 50A    |
| <b>Amperage Maximum Operating (per circuit):</b> | 20A    |
| <b>Fuse Amperages Available:</b>                 | 1A–20A |

## Input Wire Size and Current Derating Table

| AWG WIRE SIZE | METRIC WIRE SIZE    | AMPERAGE MAXIMUM OPERATING (COMBINED) |
|---------------|---------------------|---------------------------------------|
| 4/0 AWG       | 120 mm <sup>2</sup> | 280A                                  |
| 2/0 AWG       | 70 mm <sup>2</sup>  | 240A                                  |
| 1 AWG         | 50 mm <sup>2</sup>  | 180A                                  |
| 4 AWG         | 25 mm <sup>2</sup>  | 125A                                  |

## Ordering Information

| PART NUMBER | DESCRIPTION             |
|-------------|-------------------------|
| 880075      | SL PDM                  |
| 880076      | SL PDM with Manual Knob |

## Accessories Information



| PART NUMBER | DESCRIPTION           |
|-------------|-----------------------|
| 880092      | Remote Control Switch |
| 58311-09    | Remote Control Switch |

## Web Resources

Download technical resources at: [littelfuse.com/SL](http://littelfuse.com/SL)

# 880075 SL SERIES POWER DISTRIBUTION MODULES



PN 880075 with remote switching

## Dimensions in MM

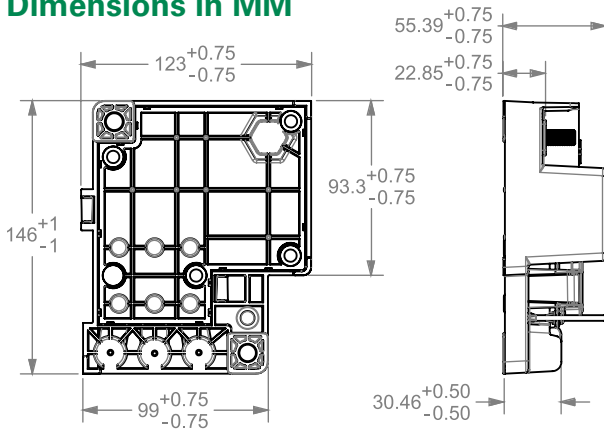

## 880075 SL Series Specifications

|  |   |
|--|---|
| <b>Voltage (nominal):</b>                        | 12V DC  |
| <b>Max Total Amperage Rating:</b>                | 300A at 85°C<br>240A at 105°C   |
| <b>Operating Temp:</b>                           | -50° C to +105° C   |
| <b>Ingress Protection:</b>                       | IP59K/IP66  |
| <b>Shock:</b>                                    | 50 G  |
| <b>Vibration</b>                                 | 8 G   |
| <b>Minimum Input Cable Size to Meet Ratings:</b> | 4/0 AWG (120 mm <sup>2</sup> )  |
| <b>Recommended Ring Terminal:</b>                | M8 (5/16")  |
| <b>Stud Size:</b>                                | M8 x 1.25   |
| <b>Stud Torque:</b>                              | 15 ft-lb (20.3 N-m)   |
| <b>Mating Connectors:</b>                        | Delphi/Aptiv APEX 2.8<br>PN: 54200409<br>Molex MX150<br>PN: 334720606 |
| <b>Weight:</b>                                   | 880075 1.4lbs (0.64kg)  |
| <b>Mounting Holes:</b>                           | 9mm (for M8 hardware)   |

## Ordering Information

| PART NUMBER | DESCRIPTION |
|-------------|-------------|
| 880075      | SL PDM      |

# 880076 SL SERIES POWER DISTRIBUTION MODULES



PN 880076 with remote switching and manual control

## Dimensions in MM

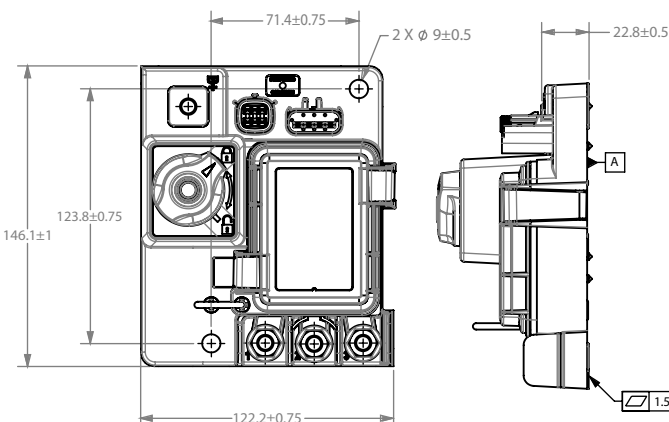

## 880076 SL Series Specifications

|  |   |
|--|---|
| <b>Voltage (nominal):</b>                        | 12V DC  |
| <b>Max Total Amperage Rating:</b>                | 300A at 85°C<br>240A at 105°C   |
| <b>Operating Temp:</b>                           | -50° C to +105° C   |
| <b>Ingress Protection:</b>                       | IP59K/IP66  |
| <b>Shock:</b>                                    | 50 G  |
| <b>Vibration</b>                                 | 8 G   |
| <b>Minimum Input Cable Size to Meet Ratings:</b> | 4/0 AWG (120 mm <sup>2</sup> )  |
| <b>Recommended Ring Terminal:</b>                | M8 (5/16")  |
| <b>Stud Size:</b>                                | M8 x 1.25   |
| <b>Stud Torque:</b>                              | 15 ft-lb (20.3 N-m)   |
| <b>Mating Connectors:</b>                        | Delphi/Aptiv APEX 2.8<br>PN: 54200409<br>Molex MX150<br>PN: 334720606 |
| <b>Weight:</b>                                   | 880076 1.5lbs (0.68kg)  |
| <b>Mounting Holes:</b>                           | 9mm (for M8 hardware)   |

## Ordering Information

| PART NUMBER | DESCRIPTION             |
|-------------|-------------------------|
| 880076      | SL PDM with Manual Knob |

# SL SERIES POWER DISTRIBUTION MODULES

## Operating Instructions

The SL PDM uses a SPDT ON-ON Remote Control Switch for control from a remote location. The Remote Control Switch should be mounted in a convenient location for quick access.

| ACTION   | OPERATIONS   | LED INDICATION   |
|--|--|--|
| To switch the battery bank and high-amperage circuits <b>ON</b>  | Depress the top part of the Remote Control Switch actuator.    | LEDs on switch and block illuminate, indicating that switched circuits are <b>ON</b> .       |
| To switch the battery bank and high-amperage circuits <b>OFF</b> | Depress the bottom part of the Remote Control Switch actuator. | LEDs on switch and block do not illuminate, indicating that switched circuits are <b>OFF</b> |

### The manual control override knob overrides the Remote Control Switch and provides:

- An added level of safety that allows manual ON-OFF control with or without power
- LOCK OFF position for servicing the electrical system or to disconnect the battery bank and high-amperage circuits in an emergency

### Unswitched Fused Circuits

Fused circuits A, B, C, and D are always on 24-hour, (non-switched), regardless of the Remote Control Switch and manual override switch states (see Illustration 1.2 - System Diagram on reverse side).

### Fuses





Unlatch the two yellow tabs on the fuse cover to access fuses.

The ATO® Fuse Block of the SL PDM is used for 24-hour (non-switched) circuits. The total continuous amperage of this block must not exceed 50A.

The MIDI® Fuse Block of the SL PDM is used for the switched circuits. The total continuous amperage of this block must not exceed 240A.

### Manual Control Override Operations

Battery bank and high-amp switched circuits 1,2, and 3 only:

| ACTION  | OPERATION   |
|---|---|
| To switch the SL PDM <b>ON</b>  | Turn manual control knob to the <b>ON</b> position and push button until latched.    |
| To switch the SL PDM <b>OFF</b>                                       | Rotate manual control knob to the <b>OFF</b> (red) position (switch contacts open).  |
| To switch the SL PDM back to <b>READY</b>                             | Rotate manual control knob back to the <b>ON</b> position.                           |
| To prevent remote operation of the SL PDM for <b>SERVICE SHUT OFF</b> | Rotate manual control knob to the <b>OFF</b> (red) position.                         |

## Installation Instructions

Install the SL PDM in a readily accessible location as close as possible to the battery. Mount in a dry and protected location. Avoid mounting directly above vented lead acid batteries so that the SL PDM is not exposed to corrosive gasses from the batteries.

Where possible, mount the SafetyHub in a vertical orientation. (See illustration 1.1 below)

### High Current Input/Remote Battery Switch Connection

Connect the positive battery terminal to the input stud on the SL PDM. Torque the connection to 15 ft-lb.

### High-Amperage Switched Fuse Circuit Connections

To connect high amperage loads such as an engine starting circuit, distribution panel, or windlass, use the numbered high amperage studs.

**CAUTION: Do not switch the Remote Control Switch to OFF while the engine is running!**

### Unswitched Fused Circuit Connections

The fuse connections labeled with letters are designed to be used for circuits that are always on.

### Control Circuit Connections (wires contained in the wire harness)

**NOTE:** The SL PDM is designed to be controlled by the Remote Control Switch. Use minimum 18 AWG (1.5mm<sup>2</sup>) wire for the control circuit.

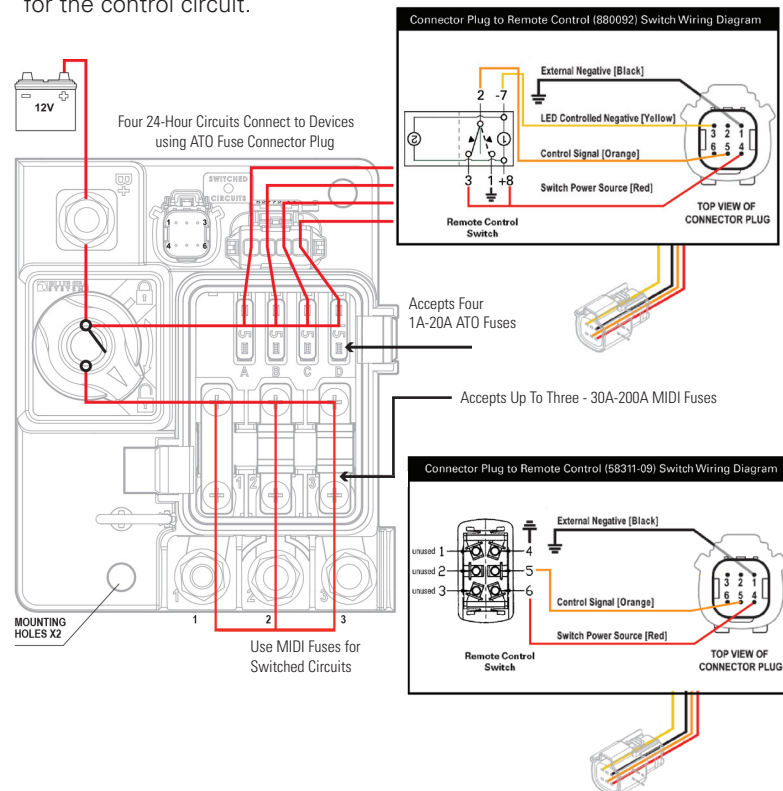

## X-ON Electronics

Largest Supplier of Electrical and Electronic Components

*Click to view similar products for [Fuse Holder](#) category:*

*Click to view products by [Littelfuse](#) manufacturer:*

Other Similar products are found below :

[570-290-741P40](#) [0031.1351.01](#) [020417G](#) [020418E](#) [6R30A1B](#) [F30A3S](#) [80910030](#) [8601.2020](#) [G15A2SPQ](#) [9-3557-GP REV A](#) [HDJ-B](#)  
[R6J30A3S](#) [HFH-1](#) [RF30A1S](#) [RF30A2B](#) [RF30A3SP](#) [BK/HHM](#) [BK/HJM-HH](#) [HTJ-LES-FUSE](#) [C4044-1](#) [2086-1](#) [2602](#) [2650](#) [178.000100](#)  
[F60A2SQ](#) [T30A2B](#) [G4PB8](#) [2660](#) [CQ-209V](#) [HKP-CCHH](#) [R6F30A2S](#) [341001A](#) [345621A](#) [348670](#) [CVRMCC](#) [4202](#) [4407](#) [4408](#) [4413](#) [4423](#)  
[4532](#) [4537](#) [TSD1404-12](#) [BPHHU](#) [HPC](#) [55900008011](#) [32NNL](#) [345602-010](#) [345603-010](#) [345612](#)