

LS2406ERQ23

28V, 6A eFuse with True Reverse Blocking and Fast Role Swap

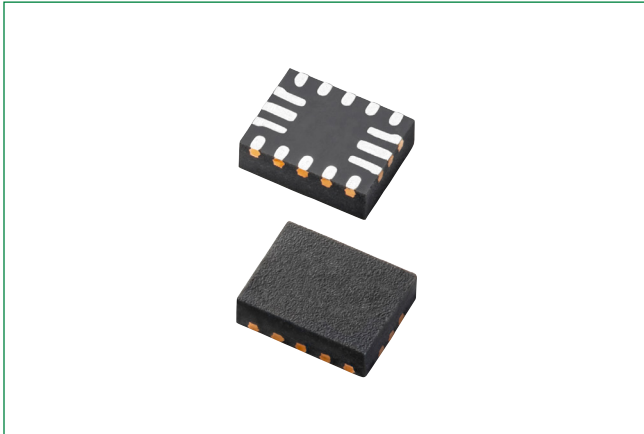

Description

The LS2406ERQ23 is an advanced 28V 6A rated current limit switch which provides overload, short circuit, input voltage surge, excessive inrush current, over-temperature and reverse current protections to the system. The built-in 24mΩ ultra low $R_{DS(ON)}$ power switch helps in reducing power loss during normal operation. Current limit level can be set up to 6A. with an external resistor. The LS2406ERQ23 integrates thermal fold-back function and over temperature shutdown protection. The LS2406ERQ23 has all time reverse current blocking function regardless of the enable signal EN logic states. A fast role swap function is also implemented to comply with the timing requirement defined in the USB Power Delivery Specification. The integrated input and output discharge function which allows the voltage levels at the input and output ports to be discharged to meet the requirement of the USB Power Delivery Specification. The LS2406ERQ23 is available in low profile 16 leads QFN 2.5mm x 3.2mm package.

Agency Approvals

Agency	Agency File/Certificate Number
	E528847

Features & Benefits

- Wide Operation Voltage Range from 3V to 24V
- 30V Maximum Input / output Voltage
- Integrate a 24mΩ Ultra Low On Protection Switch
- External Adjustable Current Limit up to 6A
- External Adjustable Input Over- voltage Protection (OVP) Threshold
- External Adjustable Soft-start (SS) Time
- Support Fast Role Swap Function through a logic signal to bypass Soft-start Time
- All Time True Reverse Current Blocking
- Short-circuit Protection
- Fault Indicator
- Input and Output Discharge Function
- Thermal Shutdown Protection and Auto Recovery
- QFN2.5x3.2_16L Packages
- Pb-Free and RoHS compliant
- UL Recognized to the requirements of UL/CSA 62368-1

Applications

- Notebook, Desktop
- Tablet
- Server
- Docking Station
- Networking
- Industry
- DC FAN
- Storage (SSD / HDD)
- Thunderbolt / USB Type-C PD

LS2406ERQ23

28V, 6A eFuse with True Reverse Blocking and Fast Role Swap

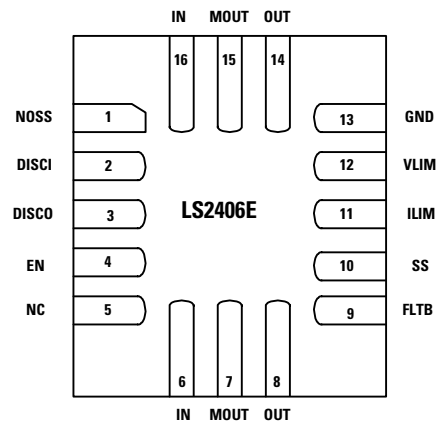
Pinout Designation

Pin #	Pin Name	Description
1	NOSS	Fast Role Swap Function enable pin. Logic Low enables soft-start during startup. The output voltage ramping up rate is set by the capacitor value on the SS pin. Logic High disables soft-start function during startup.
2	DISCI	IN port discharge control input. Logic High discharges IN port to GND through an internal 350Ω pull down resistor.
3	DISCO	OUT port discharge control input. Logic High discharges OUT port to GND through an internal 350Ω pull down resistor.
4	EN	The enable control pin of the LS2406ERQ23 chip. To enable the device this pin needs to be pulled high. Pulling this pin low disables the device. This pin has a pull-down resistor of typically 1MΩ when the device is disabled.
5	NC	Not Connection. Recommend to leave the pin float or connect to GND. Don't connect the pin to the voltage above 1V.
6,16	IN	Input Supply pin.
7,15	MOUT	The middle voltage pin between IN and OUT. Leave this pin float if it is not used. Although MOUT pin can provide power to the other circuitry when EN pin is pulled high, need to pay extra attention when use it. MOUT pin does NOT have short circuit protection, and the current drawn from MOUT pin also affects current limit setting accuracy at ILIM pin. See Application Notes how to take power from the MOUT pin.
8,14	OUT	Output pin.
9	FLT B	Fault event indicator open drain output pin. A pull-up resistor is connected from FLT B pin to any voltage less than 28V. Active Low indicates input over-voltage, over-current, over-temperature and reverse current fault events.
10	SS	Soft-start time program pin. Connect a capacitor to ground to program the soft start time.
11	ILIM	Current limit program pin. Program the switch current limit by connecting a resistor to ground. ILIM pin can't be shorted to GND. If the system requires a single component fail safe, choose 2 resistor in series to program current limit.
12	VLIM	Input over-voltage protection threshold set pin. Program input over-voltage protection threshold by connecting a resistor to ground. Recommend to set input over-voltage protection threshold range 5V to 24V.
13	GND	Ground pin.

LS2406ER023

28V, 6A eFuse with True Reverse Blocking and Fast Role Swap

Functional Block Diagram

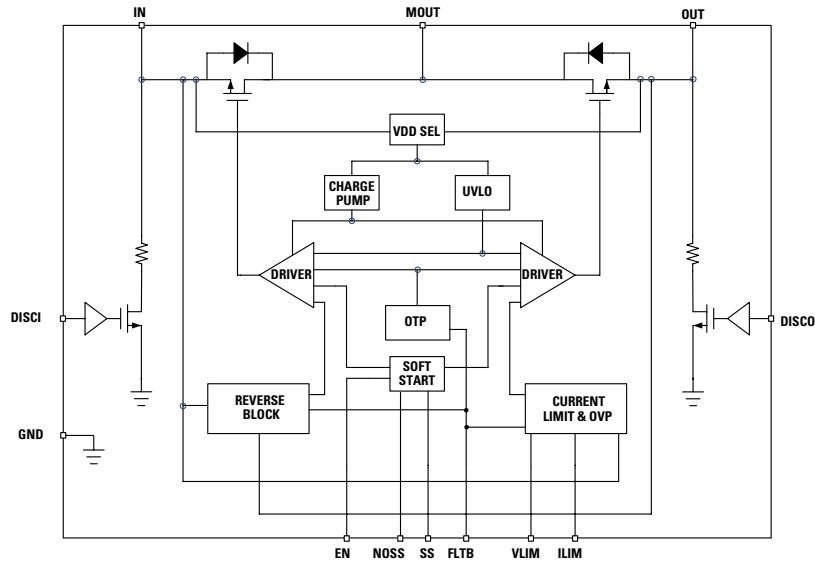

Typical Application (For USB Type-C PD Application)

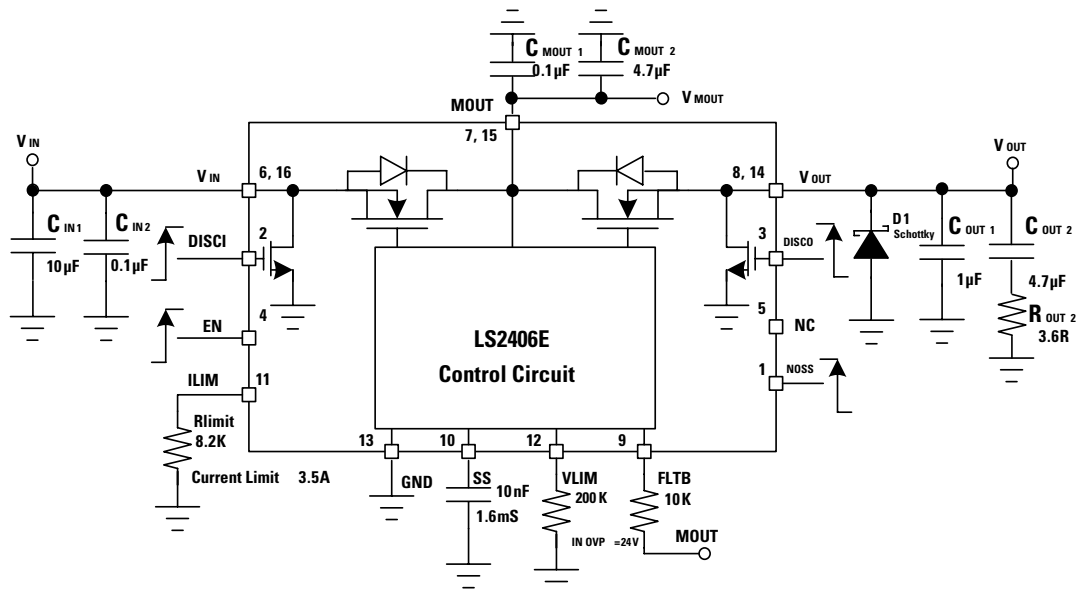

LS2406ERQ23

28V, 6A eFuse with True Reverse Blocking and Fast Role Swap

Absolute Maximum Ratings

Parameter	Value	Unit
IN, MOUT and OUT to GND	-0.3~+30	V
EN and FLTB to GND	-0.3~+28	V
IN to OUT	-30~+30	V
The other pins to GND	-0.3~+6.5	V
ESD, Human Body Model (HBM)	±2000	V
Lead Temperature (Soldering 10s)	+260	°C
Junction Temperature Range	-40 to +150	°C
Storage Temperature Range	-65 to +150	°C

Notes:

1. Stress exceeding those listed "Absolute Maximum Ratings" may damage the device.
2. ESD HBM testing per JEDEC22-A114F

Recommend Operating Conditions

Symbol	Value	Units
IN, MOUT and OUT	+3 to +24	V
Maximum Switch Continuous Current	6	A
Junction Temperature Range	-40 to +125	°C

Notes: The device is not guaranteed to function outside of the recommended operating conditions.

Thermal information

Symbol	Value	Units
Maximum Power Dissipation ($T_A=25^\circ\text{C}$)	2.6	W
Thermal Resistance (θ_{JA})	55.12	°C/W
Thermal Resistance (θ_{JC})	15.6	°C/W

Note:

1. Measured on JESD51-7, 4-Layer PCB.

2. The maximum allowable power dissipation is a function of the maximum junction temperature $T_{J,MAX}$, the junction to ambient thermal resistance θ_{JA} , and the ambient temperature T_A . The maximum allowable continuous power dissipation at any ambient temperature is calculated by $P_{D,MAX} = (T_{J,MAX} - T_A) / \theta_{JA}$. Exceeding the maximum allowable power dissipation will cause excessive die temperature, and the regulator will go into thermal shutdown. Internal thermal shutdown circuitry protects the device from permanent damage.

Electrical Characteristics

($T_A = +27^\circ\text{C}$, $V_{IN} = V_{EN} = 5\text{V}$, $R_{ILIM} = 5.6\text{k}\Omega$, $R_{VLIM} = 200\text{k}\Omega$ and $C_{SS} = 10\text{nF}$, unless otherwise specified.)

Symbol	Parameter	Test Conditions	Min	Nom	Max	Unit
V_{IN}	Input Voltage Range	-	3	-	24	V
I_Q	Quiescent Current	$V_{IN} = 5\text{V} \sim 24\text{V}$, $V_{EN} = V_{IN}$	-	450	600	μA
I_{SHDN}	Shutdown Current	$V_{IN} = 24\text{V}$, $V_{EN} = 0\text{V}$	-	10	20	μA
V_{EN_ON}	EN Turn-on Threshold	EN Rising	1.5	-	24	V
V_{EN_OFF}	EN Turn-off Threshold	EN Falling	-	-	0.4	V
R_{ENPD}	EN Pull-Down Resistance	-	-	1	-	$\text{M}\Omega$
V_{UVLO}	Input Under-voltage (UVLO) Threshold	V_{IN} Rising	-	2.95	-	V
$V_{UVLOHYS}$	Input Under-voltage Hysteresis	V_{IN} Falling	-	450	-	mV
t_{pwrldy}	Power On Delay Time	-	-	500	-	μs
$R_{DS(ON)}$	Power Switch On Resistance	$V_{IN} = 5\text{V} \sim 24\text{V}$, $I_{OUT} = 1\text{A}$	-	24	-	$\text{m}\Omega$
I_{LKG}	Power Switch Leakage Current	$V_{MOUT} = 24\text{V}$, $V_{IN} = V_{OUT} = V_{EN} = 0\text{V}$	-	0.1	10	μA
$V_{RVBINTH}$	Reverse Current Blocking Threshold	$V_{IN} - V_{OUT}$	-10	-15	-20	mV
t_{RVB}	Reverse Current Blocking Response time	-	-	-	5	μs
K_{ILIM}	Current Limit ILIM Setting Factor	$I_{ILIM} = 1\text{A} \sim 6\text{A}$	-	28	-	$\text{A} \cdot \text{k}\Omega$
I_{ILIM}	Current Limit	$R_{ILIM} = 28\text{k}\Omega$	0.9	1	1.1	A
		$R_{ILIM} = 9.33\text{k}\Omega$	2.7	3	3.3	
		$R_{ILIM} = 5.6\text{k}\Omega$	4.5	5	5.5	
K_{OVP}	Input Over-voltage Threshold V_{LIM} Setting Factor	$V_{OVP} = K_{OVP} \cdot R_{VLIM}$	-	120	-	-
I_{VLIM}	V_{LIM} Source Current	$V_{IN} = 5\text{V}$, $R_{VLIM} = 50\text{k}\Omega$	-	10	-	μA
V_{OVP}	Input Over-voltage Threshold	V_{IN} Rising, $R_{VLIM} = 50\text{k}\Omega$	-	6	-	V
		V_{IN} Rising, $R_{VLIM} = 200\text{k}\Omega$	-	24	-	

Notes:

1. for OVP3006Q33, D3, D4 (Pin16 and 17) are NC.

LS2406ERQ23**28V, 6A eFuse with True Reverse Blocking and Fast Role Swap****Electrical Characteristics**(T_A = +27°C, V_{IN} = V_{EN} = 5V, R_{ILIM} = 5.6kΩ, R_{VLIM} = 200kΩ and C_{SS} = 10nF, unless otherwise specified.) (Continued)

Symbol	Parameter	Test Conditions	Min	Nom	Max	Unit
V _{OVPHYS}	Input Over-voltage Threshold Hysteresis	V _{IN} Falling, R _{VLIM} = 50kΩ		0.7		V
		V _{IN} Falling, R _{VLIM} = 200kΩ		0.7		
T _{SS}	Soft-start Time	C _{SS} = 100nF		16		msec
		SS floating		0.8		
I _{SS}	SS bias current	V _{IN} = 5V, SS short to GND		2.5		μA
V _{FOL}	FLTB Output Low Voltage	Fault Event, I _{FLTB} = 1mA			350	mV
I _{Fkq}	FLTB Leakage Current	No Fault Event, V _{FLTB} = 5V		0.01	1	μA
T _{FLTB}	FLTB delay time	Over current or short circuit event		3		mS
	FLTB release delay time	Fault Event remove		1.5		mS
V _{IH}	NOSS, DISCI, DISCO, Logic High Threshold	V _{IN} = 5V ~ 24V	1.5		5	V
V _{IL}	NOSS, DISCI, DISCO, Logic Low Threshold	V _{IN} = 5V ~ 24V			0.4	V
I _{LKG}	NOSS, DISCI, DISCO, Input Leakage Current	V _{NOSS/DISCI/DISCO} = 0V	-1		1	μA
I _{LKG}	NOSS, Input Leakage Current	V _{NOSS} = 5V		2	5	μA
I _{LKG}	DISCI, DISCO, Input Leakage Current	V _{DISCI/DISCO} = 5V		6	9	μA
R _{DISC}	IN, OUT Discharge resistance	V _{DISCI/DISCO} = 5V		350		Ω
T _{SD}	Thermal Shutdown Temperature			150		°C
T _{HYS}	Thermal Shutdown Hysteresis			25		°C

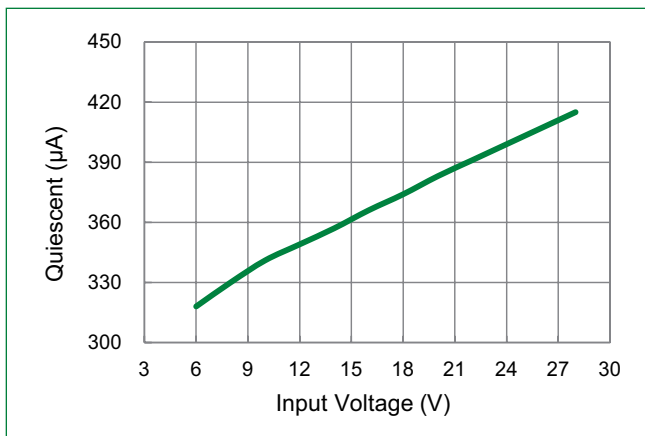
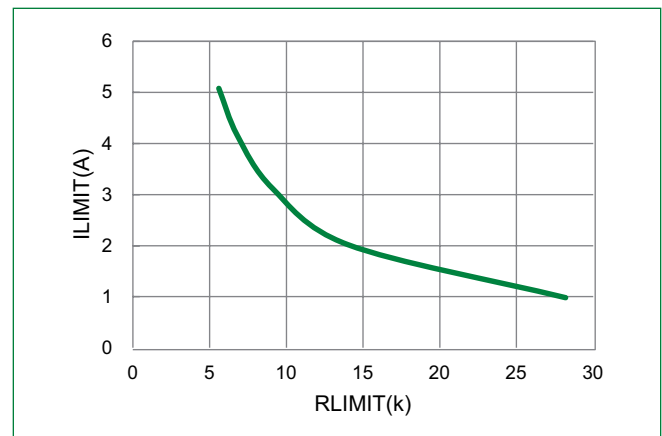
Quiescent Current Vs. Input Voltage**Current Limit Vs. RILIM Resistor Value**

LS2406ER023

28V, 6A eFuse with True Reverse Blocking and Fast Role Swap

Soft-Start Time Vs. SS Capacitance

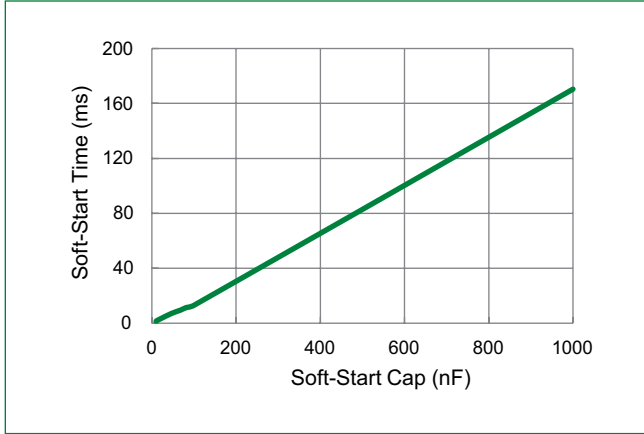

Input Over Voltage Protection

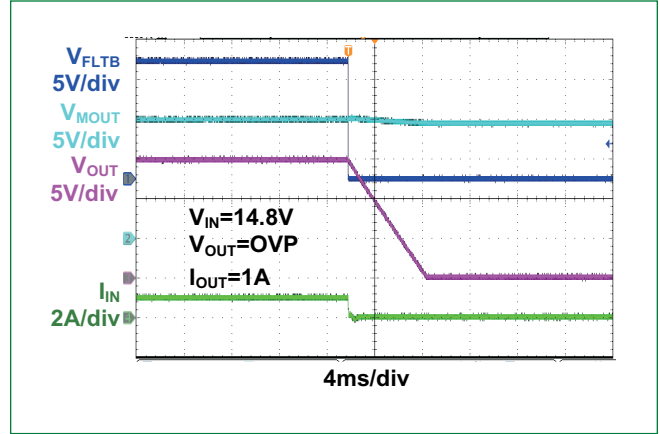

Vin Power On

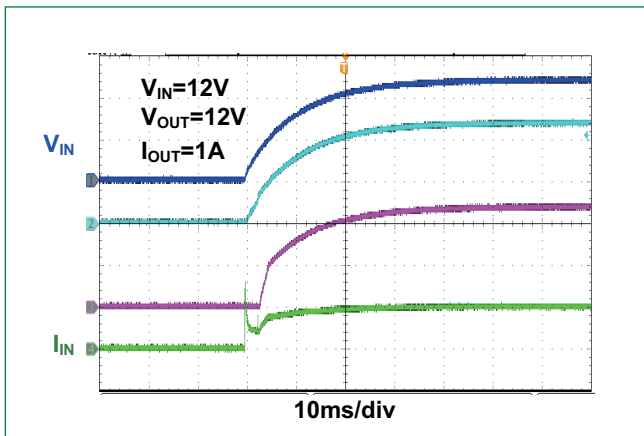

Vin Power Off

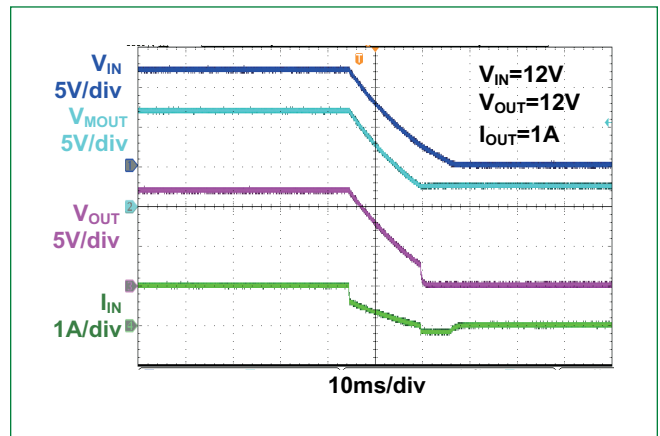

EN On

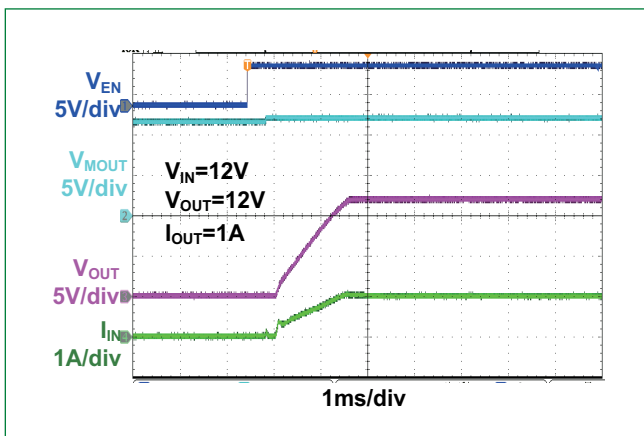

EN Off

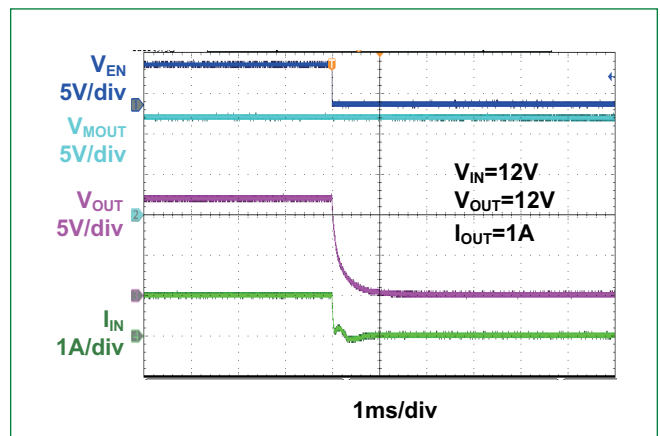

LS2406ERQ23

28V, 6A eFuse with True Reverse Blocking and Fast Role Swap

Short Circuit Protection

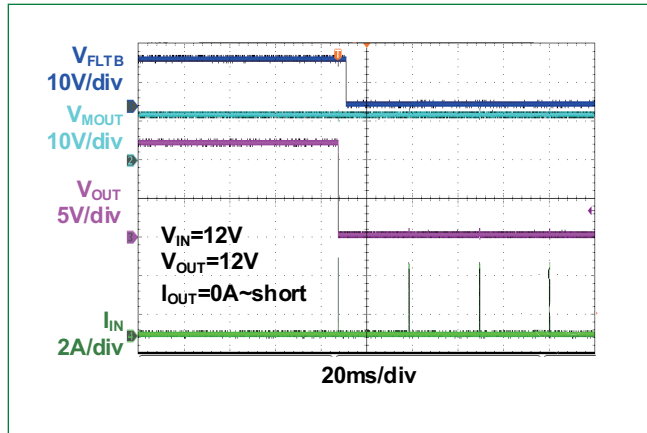

Short Circuit Protection Recovery

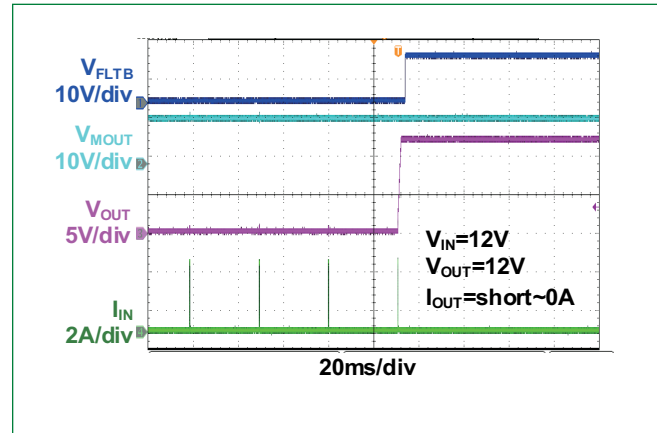

Fast Role Swap With No Soft-Start

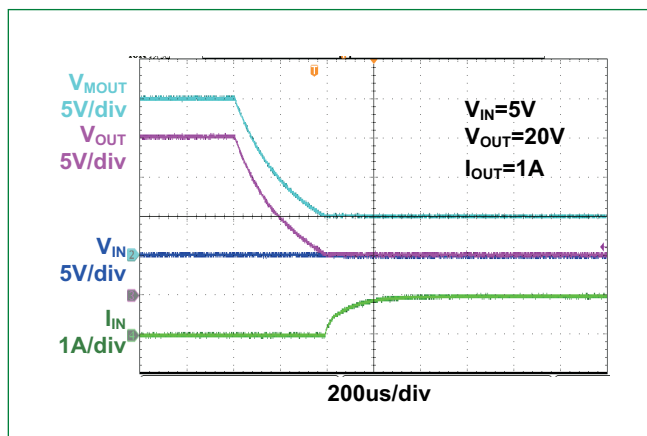

Fast Role Swap With No Soft-Start

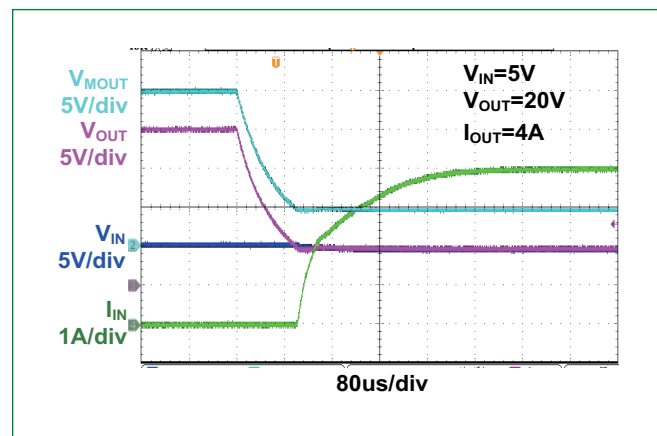

Detailed Description

The LS2406ERQ23 is an advanced current limit power switch with adjustable soft-start, adjustable current limit threshold, input under-voltage, adjustable input over-voltage, over-temperature, and short circuit protection. The integrated back-to-back power switch has a true reverse blocking function regardless of the enable pin EN logic states. When the EN pin is pulled low, the power switch is turned off to prevent current flowing back from the output OUT voltage to the input IN voltage. A high level on the EN pin enables the power switch. The power switch is turned off when the output voltage exceeds the input voltage. The power switch resumes on when the output OUT voltage drops below the input IN voltage. A low level on the NOSS pin enables the power switch soft-start function. While the input IN voltage rises, the power switch starts conducting and allows current to flow slowly from IN to OUT. Users can control the output voltage ramp-up time by connecting a capacitor between the SS pin and GND. A high level on the NOSS pin bypasses the power switch soft-start function and quickly turns on the power switch to power the system with a fast role swap requirement.

After a successful start-up sequence, the device actively monitors its load current to ensure that the overload current limit ILIMIT programmed by pin ILIMIT is not exceeded. The device monitors the input voltage and turns off the power switch if the input voltage spike exceeds the input over-voltage threshold which is set by pin VLIM. Both current limit and input over-voltage protection keep the output device safe from the harmful input voltage and current transients. The device has a built-in thermal sensor. If the device junction temperature (T_J) exceeds the thermal regulation point $+125^\circ\text{C}$, the current limit will be decreased until T_J is regulated around $+125^\circ\text{C}$. In some deadly output short circuit events, and the device junction temperature (T_J) quickly rises and exceeds the thermal shutdown threshold TSD, typically $+150^\circ\text{C}$, the device will shut down the power switch and disconnect the load from the input supply. The LS2406ERQ23 device remains off during a cooling period until the junction temperature falls below TSD -25°C , after the device will attempt to restart.

LS2406ERQ23

28V, 6A eFuse with True Reverse Blocking and Fast Role Swap

Application Information

Enable

Enable interface pin EN has ON/OFF threshold of 1.5V (Min) and 0.4V (Max) respectively. Pull EN pin low below OFF threshold (<0.4V) to disable the power switch and all protection circuits, and the device is in the low power shutdown mode and draws only 10μA current from the input supply. Pull EN pin High above ON threshold (>1.5V) to enable the power switch and all protection circuits. There is an internal 1MΩ pull-down resistor to ensure the power switch OFF if EN pin is floated. EN pin can tolerate maximum 28V voltage spike.

Input Under-voltage Lockout

When EN pin is Logic Hi, the LS2406ERQ23 monitors the input supply voltage V_{IN} and allows the power switch turning on if the input voltage is above input under-voltage lockout threshold V_{UVLO} (Typical 2.95V). If the input voltage is below input under-voltage lockout threshold V_{UVLO} , the device turns off the power switch.

Input Over-voltage Protection

When EN pin is Logic Hi, the LS2406ERQ23 monitors the input supply voltage V_{IN} . The input over-voltage protection circuit disables the power switch and pulls FLTB pin LOW to report the fault condition. If the input voltage is above input over-voltage threshold V_{OVP} . Once the input voltage drops below input over-voltage threshold V_{OVP} and no other protection circuit is active, the power switch resumes ON.

An external resistor R_{VLIM} is connected from V_{LIM} pin to GND to set the input over-voltage protection threshold V_{OVP} . The device sources typical 10μA to V_{LIM} pin. The voltage drop V_{VLIM} across the R_{VLIM} resistor externally adjusts the input over-voltage threshold from 5V to 24V using Equation (1):

$$V_{OVP} = K_{OVP} \times V_{VLIM} = 12 \times 10 \mu A \times R_{VLIM} \dots\dots\dots(1)$$

The recommended input over-voltage threshold setting is shown in the Table 1.

Table 1. Input Over-voltage Setting by An External Resistor R_{VLIM}

R_{VLIM} (kΩ)	45.8	82.5	137.5	183.3
Input Over-voltage Threshold (V)	5.5	9.9	16.5	22

Soft Start and Fast Role Swap (FRS)

When EN pin is asserted high, and NOSS pin is asserted low, the soft start control circuitry controls the gate voltage of the power switch in a manner such that the output voltage is ramped up linearly until it reaches input voltage level during power on. The in-rush current at power-on is limited by the regulated output voltage ramp up rate through the soft-start time. The built-in internal soft-start time is typical 0.8msec. If users prefers the soft-start time longer than 0.8msec, connect an external capacitor CSS between SS pin and ground to re-adjust the soft-start time. The external soft-start time is approximately calculated by Equation (2):

$$T_{SS} = C_{SS} \times 1.67 \times 10^5 \dots\dots\dots(2)$$

The recommended soft-start time setting is shown in the Table 2.

Table 2. Soft-start Time Setting by An External Capacitor CSS

CSS Value (nF)	None or < 4.7nF	10	33	47	100
Soft-start Time TSS (msec)	0.8	1.6	5.5	7.8	16.7

When both EN pin and NOSS are asserted high, the LS2406ERQ23 bypasses soft start time and turns on the power switch immediately. This feature allows the LS2406ERQ23 acting as a new power source to support the system with Fast Role Swap (FRS) requirements. Figure 2 shows the FRS timing requirement defined in the USB PD revision 3.0. To support Fast Role Swap operation, connect the LS2406ERQ23 input supply pin IN to a 5V power source and connect the LS2406ERQ23 output pin OUT to another power source V_{BUS} which supply voltage range is from 0V to 24V. When the LS2406ERQ23 output voltage is above the input voltage ($V_{OUT} - V_{IN} > 15mV$), the power switch is turned off to prevent reverse current flowing from V_{OUT} to V_{IN} . Once the output voltage falls below the input voltage ($V_{IN} > V_{OUT}$), the reverse current condition is not valid. The Fast Role Swap function is triggered, and the LS2406ERQ23 power switch is quickly switched ON within 100μs. Figure 3 show the LS2406ERQ23 FRS control sequence.

LS2406ERQ23

28V, 6A eFuse with True Reverse Blocking and Fast Role Swap

Figure 2. V_{BUS} Detection and Timing during Fast Role Swap

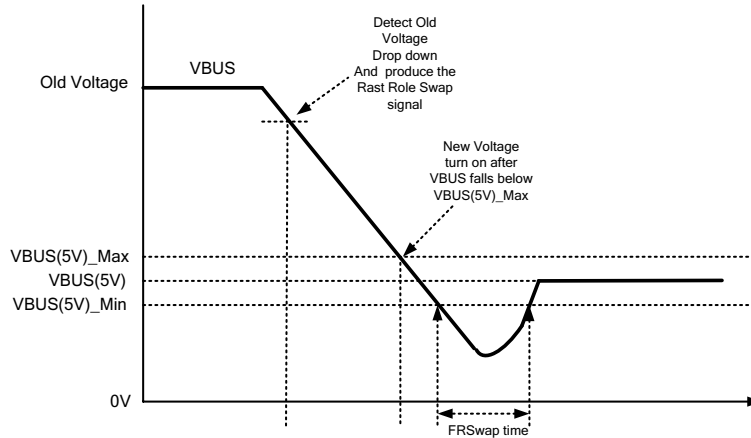
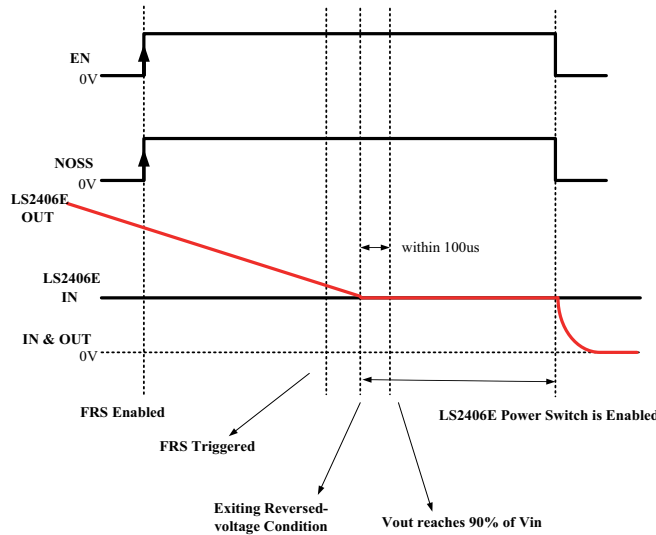

Figure 3. Fast Role Swap Control Sequence



Current Limit and Short Circuit Protection

For current limited adaptors or power sources, users can program the input current limit level to prevent the load current overload the source. The LS2406ERQ23 current limit is set with an external resistor R_{ILIM} connected between ILIM and GND. If over-load occurs, the internal circuitry limits the input current based on the value of R_{ILIM} and pulls FLTB pin LOW to report the fault condition. ILIM pin can't be short to GND. If the system requires a single component fail safe, choose two resistor in series to program input current limit. The current limit resistor R_{ILIM} is selected with Equation (3)

$$R_{ILIM} = \frac{K_{ILIM}}{I_{ILIM}} = \frac{28A * k\Omega}{I_{ILIM}} \dots \dots \dots (3)$$

The common current limit threshold setting is shown in the Table 3.

Table 3. Current Limit Setting by an External Resistor R_{ILIM}

R_{ILIM} (k Ω)	28	14	9.33	7	5.6	4.6
Current Limit I_{ILIM} (A)	1.0	2.0	3.0	4.0	5.0	6.0

LS2406ERQ23

28V, 6A eFuse with True Reverse Blocking and Fast Role Swap

The LS2406ERQ23 integrates a fast-trip comparator to quickly turn off the power switch when the output voltage shorts to ground. The device operates hiccup mode in short circuit protection. Once the short circuit fault is detected, the power switch is turned off and is forced off for a given time. At the end of the predetermined time, a restart attempt is made by soft-starting the power switch. If the overload condition no longer exists, the power switch will turn on and operate normally; otherwise, the device will see another over-current event and shut off the power switch again, repeating the previous cycle. The excess heat due to overload lasts for only a short duration in the hiccup cycle, and hence the junction temperature of the power devices is much lower.

Thermal Foldback and Thermal Shutdown Protection

The device continuously monitors the load current and keeps it limited to the value programmed by R_{ILIM} . In the normal operation or current limit protection mode, If power dissipation in the internal MOSFET PD = $(V_{IN} - V_{OUT}) \times I_{OUT}$ is too high, the LS2406ERQ23 will engage thermal foldback to reduce the current limit value so that the junction temperature (T_J) is maintained around +125°C. Figure 4 shows thermal foldback current limit. In some deadly output short circuit events, the output voltage drops with current limit I_{ILIM} . It will result in the increasing junction temperature T_J with the increased power consumption and the device junction temperature (T_J) quickly rises and exceeds the thermal shutdown threshold T_{SHDN} , typically +150°C, the device will shut down the power switch and disconnect the load from the input supply. The LS2406ERQ23 device remains off during a cooling period until the junction temperature falls below $T_{SHDN} - 20^\circ\text{C}$, after the device will attempt to restart.

Figure 4. Thermal Foldback Current Limit

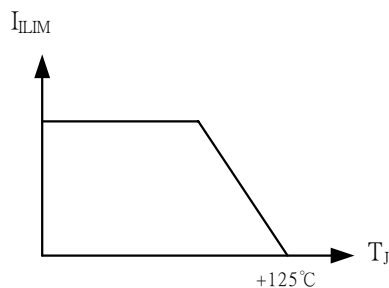

Reverse Current Protection

The LS2406ERQ23 has all time reverse current protection regardless of the EN logic level. The voltage difference $V_{IN} - V_{OUT}$ between the IN and OUT port is monitored continuously. Once the input voltage drops below the output voltage, the device immediately turns off the power switch to prevent the current flowing from the opposite direction and pulls FLTB pin LOW to report the fault condition. When the reverse current condition is no longer valid, the input voltage rises above the output voltage, the power switch resumes ON, and FLTB pin becomes high impedance HiZ.

Fault Indicator FLTB

The FLTB is an open-drain output that requires an external pull-up resistor connected to any voltage less than 28V. The pull up resistor value is recommend to be 10kΩ to 1000kΩ. FLTB pin indicates the state of the power switch. When no fault is detected and power switch is conducting, FLTB stays at high impedance HiZ. The device generates a warning flag and FLTB output low whenever one of the following fault event occurs: input over-voltage, current limit, short circuit, reverse current and over-temperature. And FLTB output change to be low with typical 3msec de-glitch time when over current or short circuit event occurs. The FLTB signal remains at 'low' until the device exits from the fault events with typical 1.5msec de-glitch time.

IN and OUT Port Discharge Function

The input IN and output OUT port discharge function is controlled via two external control inputs DISCI and DISCO, and the internal discharge resistance is around 350Ω. DISCI=Hi discharges the input IN port to GND, and DISCI=Lo disables the input discharge function. DISCO=Hi discharges the output OUT port to GND, and DISCO=Lo disables the output discharge function.

LS2406ERQ23

28V, 6A eFuse with True Reverse Blocking and Fast Role Swap

Take Power from MOUT Pin

The LS2406ERQ23 power switch consists of 2 back-to-back connected N-channel MOSFETs. MOUT is the middle voltage pin between IN and OUT. Although MOUT pin can provide power to the other circuitry when EN pin is pulled high, need to pay extra attention when use it. Bypass MOUT to GND with a minimum 0.1 μ F MLCC capacitor if MOUT pin is used. The current drawn from MOUT pin affects input current limit setting accuracy at ILIM pin. Due to body diode of the power MOSFETs in LS2406ERQ23, MOUT pin is NOT protected from over-load and short circuit fault events. Whenever the input voltage is applied on IN pin, MOUT will follow the input voltage through either the power MOSFET M1 or M1 body diode. When a short circuit occurs on the MOUT pin, the current can NOT be limited by the LS2406ERQ23. If over load or short circuit protection is required for the MOUT pin, recommend to add a load switch between MOUT pin and any downstream circuits.

Input Capacitor Selection

Place a high quality 0.1 μ F in parallel with at least a 4.7 μ F or higher ceramic type X5R or X7R bypass capacitor from the IN pin to ground GND for proper decoupling. The input capacitor voltage rating should exceed the maximum input voltage range.

Output Capacitor Selection

Place a high quality 0.1 μ F in parallel with at least 4.7 μ F or higher ceramic type X5R or X7R bypass capacitor at the OUT pin to ground GND for proper decoupling. The output capacitor voltage rating should exceed the maximum input voltage range.

USB Type-C Cable Short Circuit Protection

The OUT pin of the LS2406ERQ23 is connected to USB Type-C cable V_{BUS} pin. When a USB cable is hot plugged in/out of the USB Type-C connector, large ground current could be seen at the V_{BUS} pin. When the far end of a connected cable is short to ground for whatever reason, the OUT pin of the LS2406ERQ23 could also see a large ground current. The large ground current with high slew rate di/dt can cause the LS2406ERQ23 OUT pin going negative voltage up to -10V due to the USB Type-C cable parasitic inductance. The excessive negative voltage spike will trigger on the LS2406ERQ23 internal OUT pin ESD diode and put voltage stress on the internal power switch. If the voltage difference between LS2406ERQ23 IN pin and OUT pin exceeds 28V, the power switch will be permanently damaged. Recommend to place a Schottky diode as close as possible to the LS2406ERQ23's OUT pin to help absorb large GND current which may result in LS2406ERQ23 false operation. Another method of clamping the V_{BUS} negative voltage spike is to use a RC snubber. The RC snubber modifies the characteristic of total RLC response in the USB Type-C cable hot-plug from being under-damped to critically-damped or over-damped in the USB cable hot-plug. The RC snubber actually changes the hot-plug response, so the voltage on V_{BUS} does not ring and the voltage is limited. However, the USB Type-C and Power Delivery specifications limit the range of capacitance that can be used on V_{BUS} for the RC snubber. V_{BUS} capacitance must have a minimum 1 μ F and a maximum of 10 μ F. The RC snubber values chosen support up to 4 meter USB Type-C cable (maximum length allowed in the USB Type-C specification) being hot plugged, is to use 4.7 μ F capacitor in series with a 3.6- Ω resistor. In parallel with the RC snubber a 1 μ F capacitor is used, which always ensures the minimum USB Type-C V_{BUS} capacitance specification is met. This V_{BUS} clamping circuit is shown below in Figure 6.

Figure 6. Clamp USB Type-C V_{BUS} overshoot/undershoot with a Schottky Diode and RC Snubber

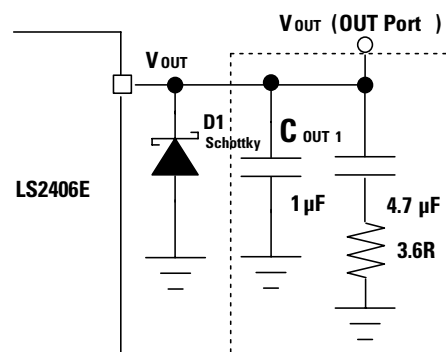

LS2406ERQ23

28V, 6A eFuse with True Reverse Blocking and Fast Role Swap

Application 1 Schematic

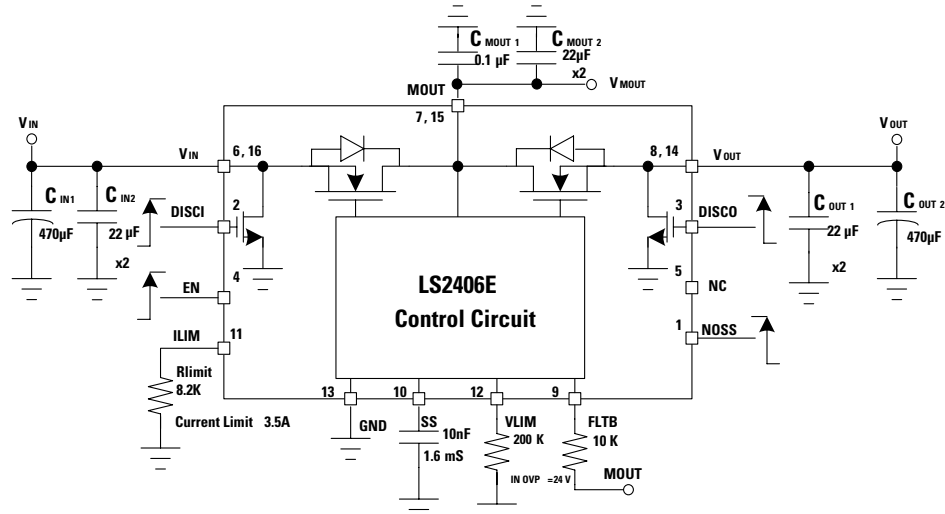

Bill of Materials

Qty	Ref	Value	Description	Package
2	C _{CIN2}	22µF	Ceramic Capacitor, 50V, X5R	1206
2	C _{MOUT2}	22µF	Ceramic Capacitor, 50V, X5R	1206
2	C _{OUT1}	22µF	Ceramic Capacitor, 50V, X5R	1206
2	C _{IN1} , C _{OUT2}	470µF	Electrolytic Capacitor, 50V	8x12mm
1	C _{MOUT1}	100nF	Ceramic Capacitor, 10V, X5R	0603
1	C _{SS}	10nF	Ceramic Capacitor, 10V, X5R	0603
1	R _{LIMIT}	8.2KΩ	Resistor, ±1%	0603
1	R _{FLT}	10KΩ	Resistor, ±1%	0603
1	R _{VLIM}	200K	Resistor, ±1%	0603
1	Power IC	LS2406ERQ23	eFuse IC	QFN2.5x3.2

LS2406ERQ23

28V, 6A eFuse with True Reverse Blocking and Fast Role Swap

Application2 Schematic for USB Type-C Application

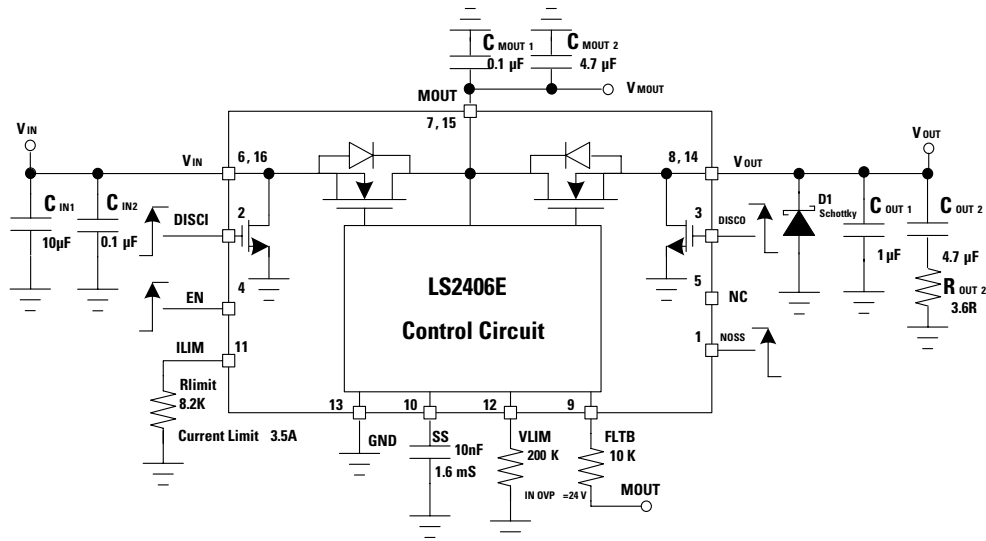

Bill of Materials

Qty	Ref	Value	Description	Package
1	C _{IN1}	10µF	Ceramic Capacitor, 50V, X5R	1206
2	C _{OUT1} , C _{MOUT2}	1µF	Ceramic Capacitor, 50V, X5R	0805
1	C _{OUT2}	4.7µF	Ceramic Capacitor, 50V, X5R	0805
2	C _{IN2} , C _{MOUT1}	0.1µF	Ceramic Capacitor, 50V, X5R	1206
1	R _{OUT2}	3.6	Resistor, ±1%	0805
1	D ₁	SL34PL	Schottky Diode	1206
1	C _{SS}	10nF	Ceramic Capacitor, 10V, X5R	0603
1	R _{LIMIT}	8.2KΩ	Resistor, ±1%	0603
1	R _{FLT}	10KΩ	Resistor, ±1%	0603
1	R _{VLIM}	200K	Resistor, ±1%	0603
1	Power IC	LS2406ERQ23	eFuse IC	QFN2.5x3.2_16

Part Numbering

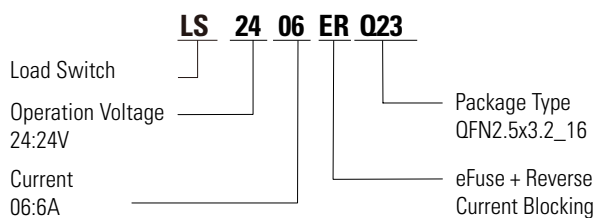

Part Marking

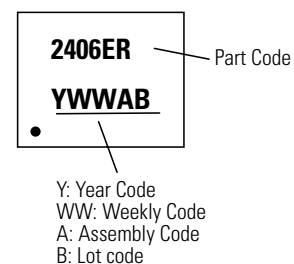

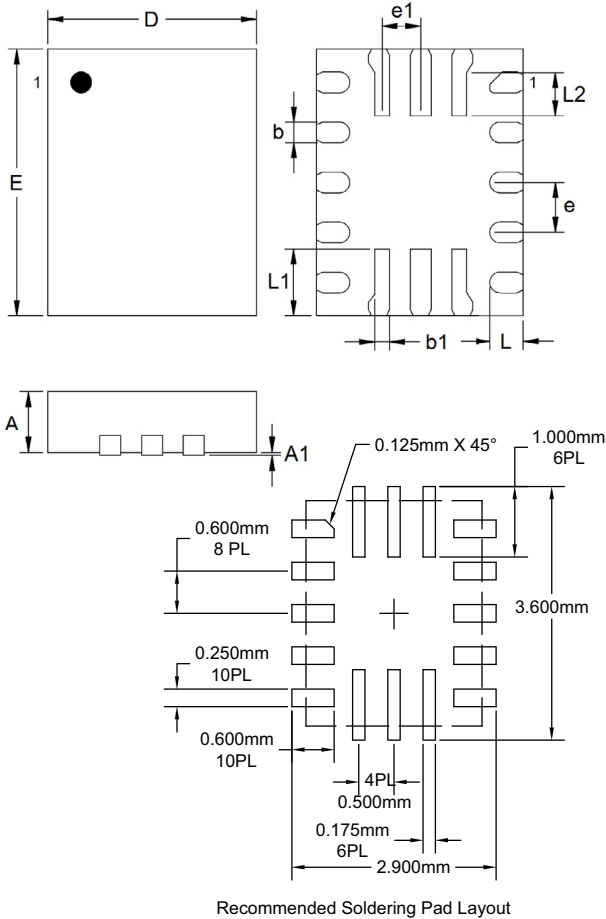
LS2406ERQ23**28V, 6A eFuse with True Reverse Blocking and Fast Role Swap****Dimensions – QFN 16L 2.5x3.2mm**

Dimension	Millimeters		Inches	
	MIN	MAX	MIN	MAX
A	0.70	0.80	0.028	0.031
A1	0.00	0.05	0.000	0.002
b	0.20	0.30	0.008	0.012
b1	0.12	0.23	0.005	0.009
D	2.40	2.60	0.094	0.102
E	3.10	3.30	0.122	0.130
e	0.60 BSC		0.024 BSC	
e1	0.50 BSC		0.020 BSC	
L	0.30	0.50	0.012	0.020
L1	0.70	0.90	0.028	0.035
L2	0.52 REF		0.020 REF	

* BSC = Basic Spacing between Centers

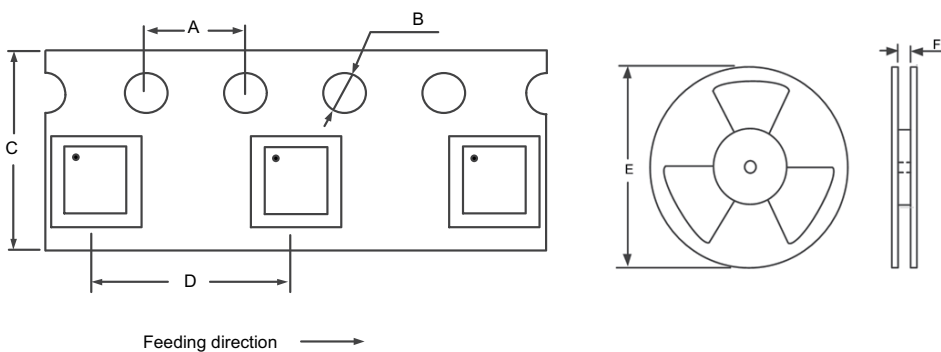
Carrier Tape & Reel Specification – QFN 16L 2.5x3.2mm

Symbol	Millimeters
A	4.0
B	1.5
C	12.0
D	8.0
E	13 inch
F	13.0

Ordering Information

Part Number	Component Package	Quantity	Packaging Option
LS2406ERQ23	QFN 16L 2.5x3.2mm	5000	Tape & Reel

Product Disclaimer - Littelfuse products are not designed for, and shall not be used for, any purpose (including, without limitation, automotive, military, aerospace, medical, life-saving, life-sustaining or nuclear facility applications, devices intended for surgical implant into the body, or any other application in which the failure or lack of desired operation of the product may result in personal injury, death, or property damage) other than those expressly set forth in applicable Littelfuse product documentation. Warranties granted by Littelfuse shall be deemed void for products used for any purpose not expressly set forth in applicable Littelfuse documentation. Littelfuse shall not be liable for any claims or damages arising out of products used in applications not expressly intended by Littelfuse as set forth in applicable Littelfuse documentation. The sale and use of Littelfuse products is subject to Littelfuse Terms and Conditions of Sale, unless otherwise agreed by Littelfuse. "Littelfuse" includes Littelfuse, Inc., and all of its affiliate entities.

<https://www.littelfuse.com/legal/disclaimers/product-disclaimer.aspx>

X-ON Electronics

Largest Supplier of Electrical and Electronic Components

Click to view similar products for [Power Switch ICs - Power Distribution](#) category:

Click to view products by [Littelfuse](#) manufacturer:

Other Similar products are found below :

[TLE6232GP](#) [NCP45520IMNTWG-L](#) [VND5E004ATR-E](#) [FPF1018](#) [DS1222](#) [NCV380HMUAJAATBG](#) [SZNCP3712ASNT3G](#)
[NCP45520IMNTWG-H](#) [VND5004ATR-E](#) [AP22811BW5-7](#) [SLG5NT1437VTR](#) [SZNCP3712ASNT1G](#) [DML1008LDS-7](#) [TS13011-QFNR](#)
[VND7012AYTR](#) [NCV459MNWTBG](#) [NCP4545IMNTWG-L](#) [NCV8412ASTT1G](#) [NCV8412ASTT3G](#) [FPF2260ATMX](#) [SLG5NT1765V](#)
[SLG5NT1757V](#) [NCP45780IMN24RTWG](#) [AP2151DMPG-13](#) [AP2151AMP-13](#) [NCP45540IMNTWG-L](#) [TPS2022P](#) [FPF2495BUCX](#)
[NCP45650IMNTWG](#) [NCV8412ADDR2G](#) [DK5V100R20S](#) [BTS7020-2EPA](#) [BTT6100-2ERA](#) [BTS71220-4ESA](#) [DK5V100R15M](#)
[WS3220C9-9/TR](#) [AW32405CSR](#) [BTT6030-2ERA](#) [TLE75602-ESH](#) [BTS5200-4EKA](#) [DK5V150R25M](#) [DK5V45R25](#) [DK5V100R25S](#)
[AW35206FOR](#) [BTS7120-2EPA](#) [TLE75008-ESD](#) [BTS7040-1EPA](#) [BTT6030-1ERA](#) [DK5V60R10S](#) [DK5V45R25S](#)