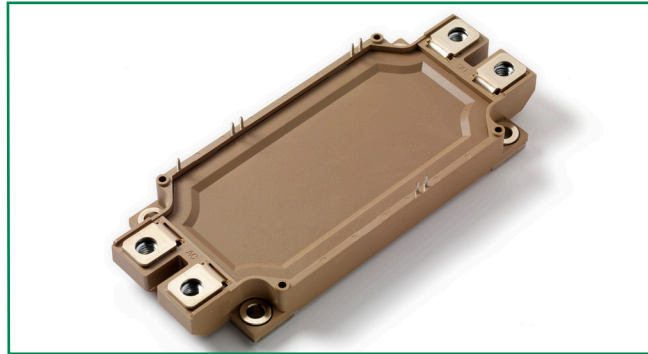

### MG12225WB-BN2MM

#### Features

- IGBT<sup>3</sup> CHIP(Trench+Field Stop technology)
- Low saturation voltage and positive temperature coefficient
- Fast switching and short tail current
- Free wheeling diodes with fast and soft reverse recovery
- Temperature sense included

#### Applications

- AC motor control
- Motion/servo control
- Photovoltaic/Fuel cell
- Inverter and power supplies

#### Module Characteristics (T<sub>j</sub> = 25°C, unless otherwise specified)

Symbol	Parameters	Test Conditions	Min	Typ	Max	Unit
T <sub>Jmax</sub>	Max. Junction Temperature				150	°C
T <sub>Jop</sub>	Operating Temperature		-40		125	°C
T <sub>stg</sub>	Storage Temperature		-40		125	°C
V <sub>isol</sub>	Insulation Test Voltage	AC, t=1min		3000		V
CTI	Comparative Tracking Index		250			
Torque	Module-to-Sink	Recommended (M5)	2.5		5	N·m
Torque	Module Electrodes	Recommended (M6)	3		5	N·m
Weight				350		g

#### Absolute Maximum Ratings (T<sub>j</sub> = 25°C, unless otherwise specified)

Symbol	Parameters	Test Conditions	Values	Unit
<b>IGBT</b>				
V <sub>CES</sub>	Collector - Emitter Voltage	T <sub>j</sub> =25°C	1200	V
V <sub>GES</sub>	Gate - Emitter Voltage		±20	V
I <sub>C</sub>	DC Collector Current	T <sub>C</sub> =25°C	325	A
		T <sub>C</sub> =80°C	225	A
I <sub>CM</sub>	Repetitive Peak Collector Current	t <sub>p</sub> =1ms	450	A
P <sub>tot</sub>	Power Dissipation Per IGBT		1050	W
<b>Diode</b>				
V <sub>RRM</sub>	Repetitive Reverse Voltage	T <sub>j</sub> =25°C	1200	V
I <sub>F(AV)</sub>	Average Forward Current	T <sub>C</sub> =25°C	225	A
		T <sub>C</sub> =80°C	160	A
I <sub>FRM</sub>	Repetitive Peak Forward Current	t <sub>p</sub> =1ms	450	A
I <sup>2</sup> t		T <sub>j</sub> =125°C, t=10ms, V <sub>R</sub> =0V	9100	A <sup>2</sup> s

### Electrical and Thermal Specifications ( $T_J = 25^\circ\text{C}$ , unless otherwise specified)

Symbol	Parameters	Test Conditions	Min	Typ	Max	Unit
<b>IGBT</b>						
$V_{GE(th)}$	Gate - Emitter Threshold Voltage	$V_{CE}=V_{GE}, I_C=9\text{mA}$	5.0	5.8	6.5	V
$V_{CE(sat)}$	Collector - Emitter	$I_C=225\text{A}, V_{GE}=15\text{V}, T_J=25^\circ\text{C}$		1.7		V
	Saturation Voltage	$I_C=225\text{A}, V_{GE}=15\text{V}, T_J=125^\circ\text{C}$		2.0		V
$I_{ICES}$	Collector Leakage Current	$V_{CE}=1200\text{V}, V_{GE}=0\text{V}, T_J=25^\circ\text{C}$			1	mA
		$V_{CE}=1200\text{V}, V_{GE}=0\text{V}, T_J=125^\circ\text{C}$			5	mA
$I_{GES}$	Gate Leakage Current	$V_{CE}=0\text{V}, V_{GE}=\pm 15\text{V}, T_J=125^\circ\text{C}$	-400		400	nA
$R_{Gint}$	Integrated Gate Resistor			3.3		$\Omega$
$Q_{ge}$	Gate Charge	$V_{CE}=600\text{V}, I_C=225\text{A}, V_{GE}=\pm 15\text{V}$		2.1		$\mu\text{C}$
$C_{ies}$	Input Capacitance	$V_{CE}=25\text{V}, V_{GE}=0\text{V}, f=1\text{MHz}$		16		nF
$C_{res}$	Reverse Transfer Capacitance				0.75	
$t_{d(on)}$	Turn - on Delay Time	$V_{CC}=600\text{V}$ $I_C=225\text{A}$ $R_G=3.3\Omega$ $V_{GE}=\pm 15\text{V}$ Inductive Load	$T_J=25^\circ\text{C}$		160	ns
			$T_J=125^\circ\text{C}$		170	ns
$t_r$	Rise Time		$T_J=25^\circ\text{C}$		45	ns
			$T_J=125^\circ\text{C}$		50	ns
$t_{d(off)}$	Turn - off Delay Time		$T_J=25^\circ\text{C}$		460	ns
			$T_J=125^\circ\text{C}$		530	ns
$t_f$	Fall Time		$T_J=25^\circ\text{C}$		100	ns
			$T_J=125^\circ\text{C}$		150	ns
$E_{on}$	Turn - on Energy		$T_J=25^\circ\text{C}$		9	mJ
			$T_J=125^\circ\text{C}$		13.5	mJ
$E_{off}$	Turn - off Energy	$T_J=25^\circ\text{C}$		22.5	mJ	
		$T_J=125^\circ\text{C}$		33	mJ	
$I_{SC}$	Short Circuit Current	$t_{psc} \leq 10\mu\text{s}, V_{GE}=15\text{V}, T_J=125^\circ\text{C}, V_{CC}=900\text{V}$		900		A
$R_{thJC}$	Junction-to-Case Thermal Resistance (Per IGBT)				0.12	K/W
<b>Diode</b>						
$V_F$	Forward Voltage	$I_F=225\text{A}, V_{GE}=0\text{V}, T_J=25^\circ\text{C}$		1.65		V
		$I_F=225\text{A}, V_{GE}=0\text{V}, T_J=125^\circ\text{C}$		1.6		V
$t_{RR}$	Reverse Recovery Time	$I_F=225\text{A}, V_R=600\text{V}$ $di_F/dt=-3600\text{A}/\mu\text{s}$ $T_J=125^\circ\text{C}$		200		ns
$I_{RRM}$	Max. Reverse Recovery Current			180		A
$E_{rec}$	Reverse Recovery Energy			18		mJ
$R_{thJCD}$	Junction-to-Case Thermal Resistance (Per Diode)				0.2	K/W

### NTC Characteristics ( $T_J = 25^\circ\text{C}$ , unless otherwise specified)

Symbol	Parameters	Test Conditions	Min	Typ	Max	Unit
$R_{25}$	Resistance	$T_c=25^\circ\text{C}$		5		K $\Omega$
$B_{25/50}$				3375		K

**Figure 1: Typical Output Characteristics for IGBT Inverter**

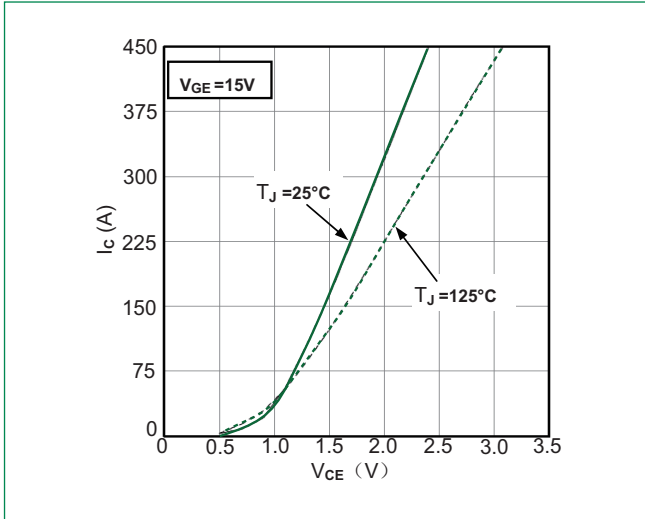

**Figure 2: Typical Output Characteristics for IGBT Inverter**

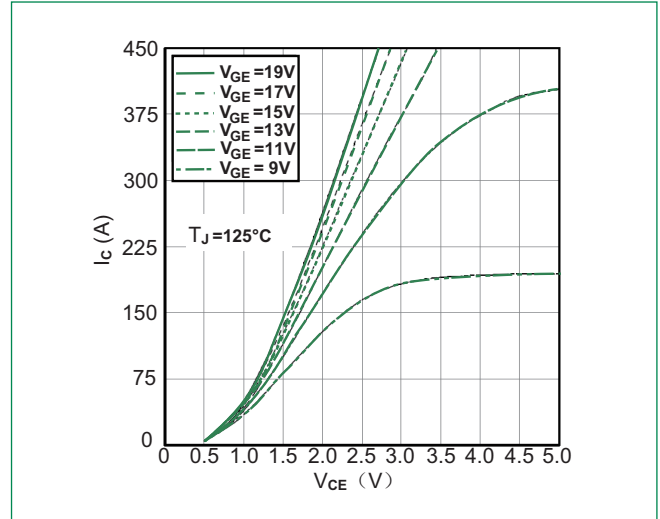

**Figure 3: Typical Transfer Characteristics for IGBT Inverter**

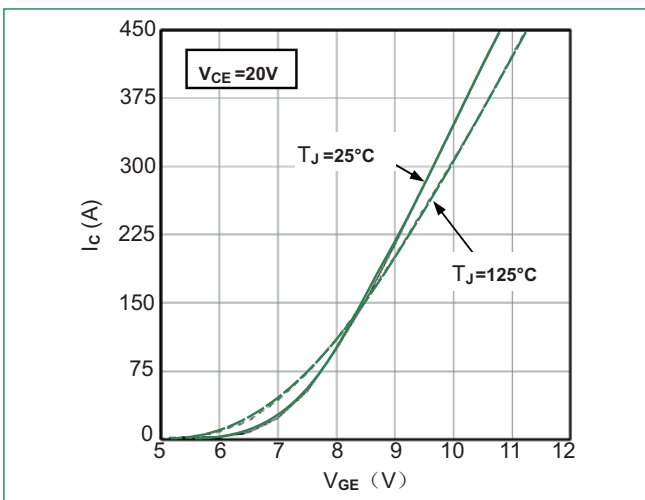

**Figure 4: Switching Energy vs. Gate Resistor for IGBT Inverter**

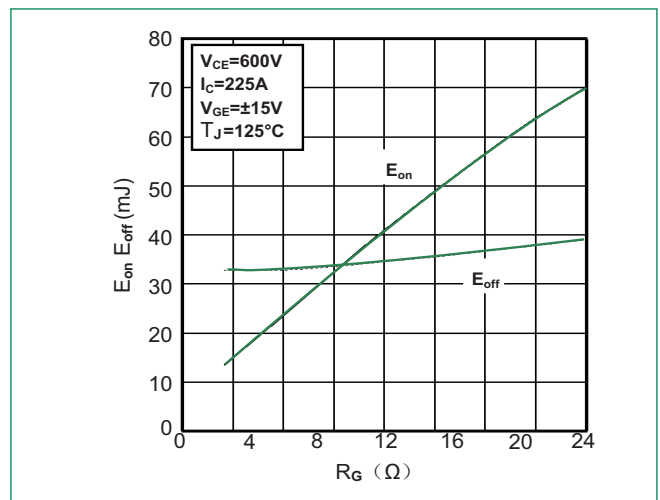

**Figure 5: Switching Energy vs. Collector Current for IGBT Inverter**

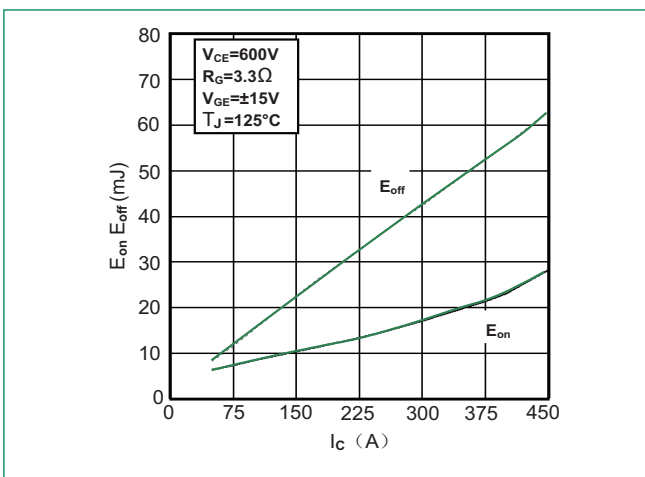

**Figure 6: Reverse Biased Safe Operating Area for IGBT Inverter**

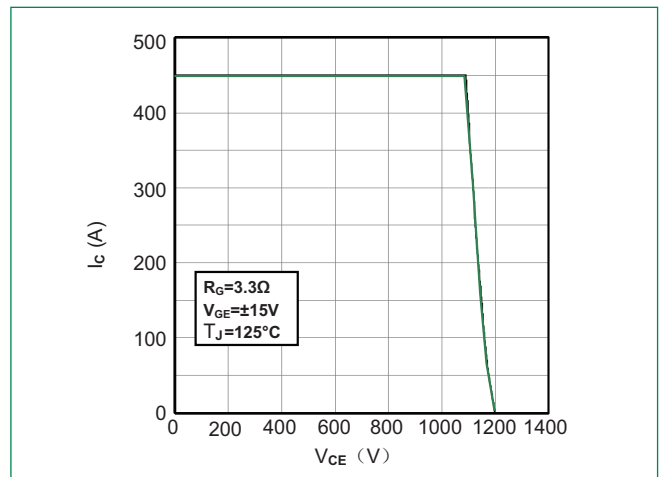

**Figure 7: Diode Forward Characteristics for Diode Inverter**

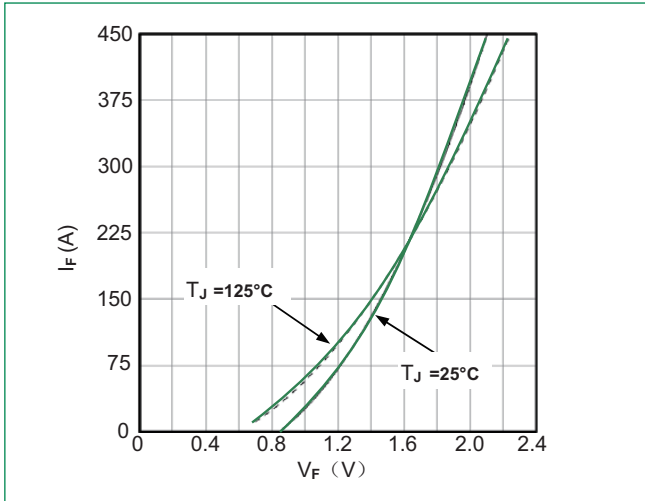

**Figure 8: Switching Energy vs. Gate Resistort for Diode Inverter**

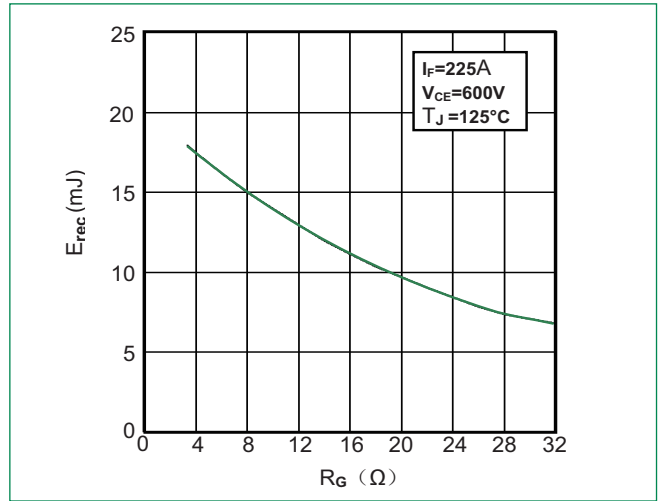

**Figure 9: Transient Thermal Impedance of Diode and IGBT Inverter**

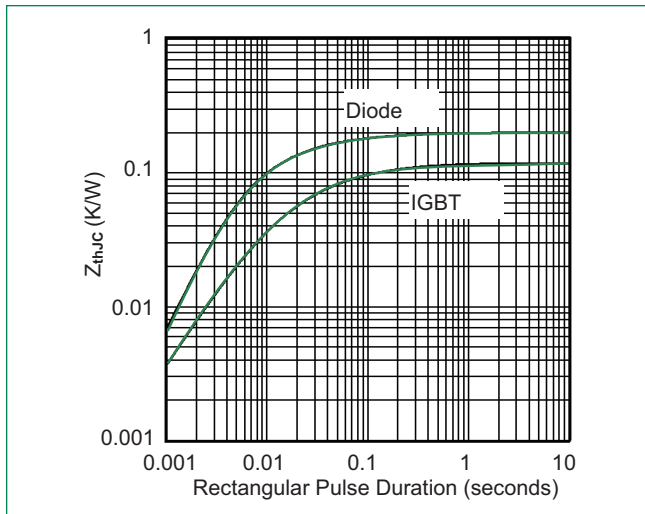

**Figure 10: NTC Characteristics**

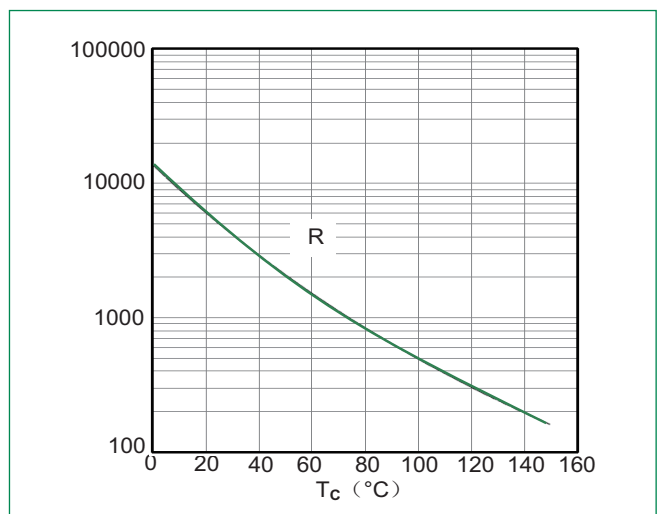

### Circuit Diagram



### Dimensions-Package WB

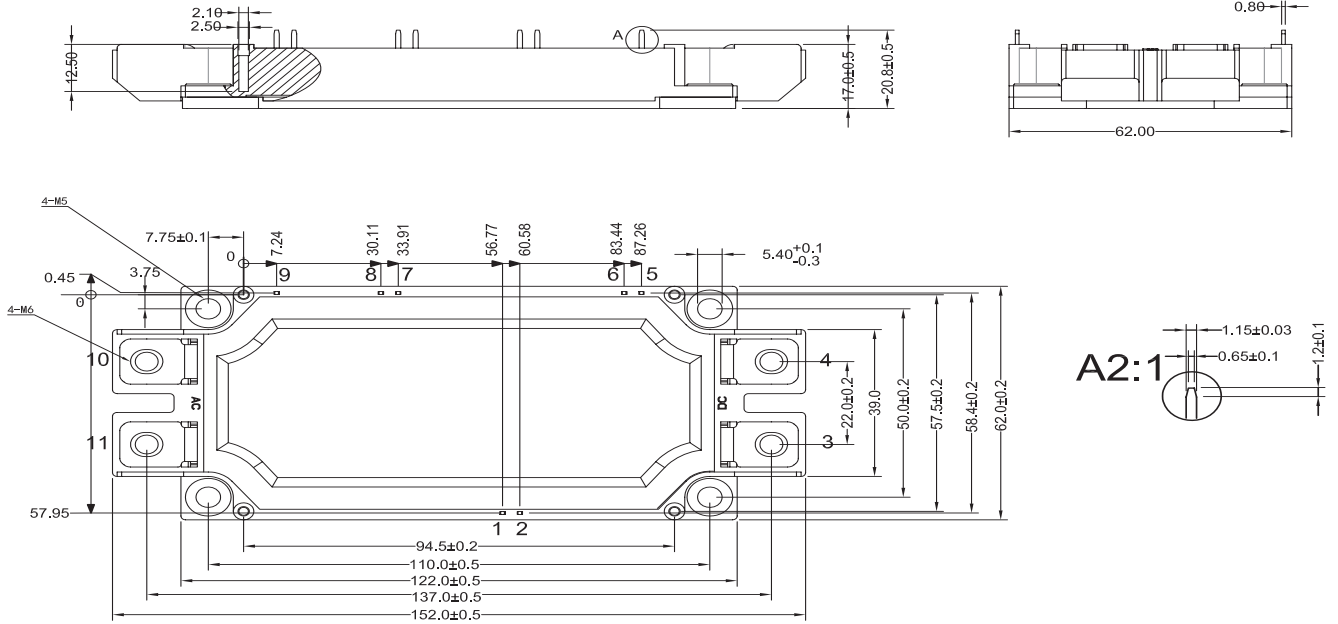

The foot pins are in gold / nickel coating

### Packing Options

Part Number	Marking	Weight	Packing Mode	M.O.Q
MG12225WB-BN2MM	MG12225WB-BN2MM	350g	Bulk Pack	60

### Part Numbering System

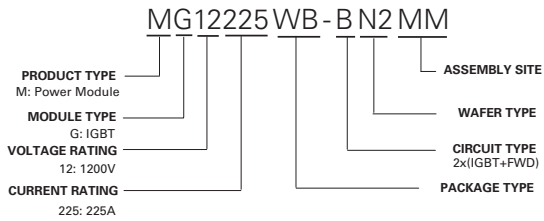

### Part Marking System

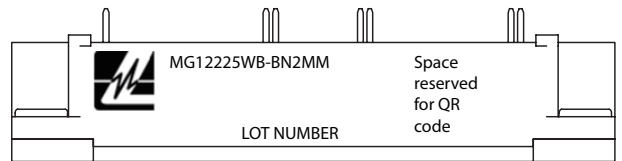

## X-ON Electronics

Largest Supplier of Electrical and Electronic Components

*Click to view similar products for [IGBT Modules category](#):*

*Click to view products by [Littelfuse manufacturer](#):*

Other Similar products are found below :

[F3L400R07ME4\\_B22](#) [F4-50R07W2H3\\_B51](#) [FB15R06W1E3](#) [FB20R06W1E3\\_B11](#) [FD1000R33HE3-K](#) [FD400R33KF2C-K](#)  
[FD401R17KF6C\\_B2](#) [FD-DF80R12W1H3\\_B52](#) [FF200R06YE3](#) [FF300R12KE4\\_E](#) [FF450R12ME4P](#) [FF600R12IP4V](#) [FP10R06W1E3\\_B11](#)  
[FP20R06W1E3](#) [FP50R12KT3](#) [FP75R07N2E4\\_B11](#) [FS10R12YE3](#) [FS150R07PE4](#) [FS150R12PT4](#) [FS200R12KT4R](#) [FS50R07N2E4\\_B11](#)  
[FZ1000R33HE3](#) [FZ1800R17KF4](#) [DD250S65K3](#) [DF1000R17IE4](#) [DF1000R17IE4D\\_B2](#) [DF1400R12IP4D](#) [DF200R12PT4\\_B6](#)  
[DF400R07PE4R\\_B6](#) [BSM75GB120DN2\\_E3223c-Se](#) [F3L300R12ME4\\_B22](#) [F3L75R07W2E3\\_B11](#) [F4-50R12KS4\\_B11](#)  
[F475R07W1H3B11ABOMA1](#) [FD1400R12IP4D](#) [FD200R12PT4\\_B6](#) [FD800R33KF2C-K](#) [FF1200R17KP4\\_B2](#) [FF300R17KE3\\_S4](#)  
[FF300R17ME4\\_B11](#) [FF401R17KF6C\\_B2](#) [FF650R17IE4D\\_B2](#) [FF900R12IP4D](#) [FF900R12IP4DV](#) [STGIF7CH60TS-L](#) [FP50R07N2E4\\_B11](#)  
[FS100R07PE4](#) [FS150R07N3E4\\_B11](#) [FS150R17N3E4](#) [FS150R17PE4](#)