

MHP-TAM DEVICES:

MHP with Thermal Activation

The rapidly expanding market for ultra-thin portable electronic devices, such as media tablets and ultra-thin PCs, has created demand for very thin, low-profile, lightweight and high-capacity Lithium Polymer (LiP) and prismatic cells.

A new MHP (Metal Hybrid PPTC) device, the MHP-TAM device, offers a 9V_{DC} rating and a higher current rating than typical battery strap devices. This helps them meet the battery safety requirements of higher-capacity LiP and prismatic batteries found in the latest tablet and ultra-thin computing products. Hybrid MHP technology connects a bimetal protector in parallel with a PPTC (polymeric positive temperature coefficient) device. The resulting MHP-TAM (Thermal Activation) series helps provide resettable overtemperature protection, while utilizing the PPTC device to act as a heater and to help keep the bimetal latched until the fault is removed.



BENEFITS

- Capable of handling the higher voltages and battery discharge rates found in high-capacity LiP and prismatic cell applications
- Helps provide resettable overtemperature protection in high-capacity LiP and prismatic cell applications

FEATURES

- 9V_{DC} rating
- Two levels of current carrying capacity:
 - Low current (nominal 6A hold current @25°C)
 - High current (nominal 15A hold current @25°C)
- Multiple activation temperature ratings (72°C, 77°C, 82°C, 85°C, 90°C)
- Compact size (L: 5.8mm x W: 3.85mm x H: 1.15mm) allows for ultra-thin battery pack designs

APPLICATIONS

Battery cell protection for high-capacity Lithium Polymer and prismatic cells used in:

- Notebook PCs
- Ultra-book
- Tablets
- Smart phones

MHP-TAM Devices: MHP with Thermal Activation

Table M1 – Electrical Characteristics for MHP-TAM15 Series

Model Number	Rating [°C] Nominal	Operation Temperature [°C]		Reset Temperature [°C]		Reference Resistance [mohms] 25°C	
		Min	Max	Min	ΔT	Typ	Max
MHP-TAM15-9-72	72	67	77	≥40	≥7	2.5	5
MHP-TAM15-9-77	77	72	82	≥40	≥10	2.5	5
MHP-TAM15-9-82	82	77	87	≥40	≥10	2.5	5
MHP-TAM15-9-85	85	80	90	≥40	≥10	2.5	5
MHP-TAM15-9-90	90	85	95	≥40	≥10	2.5	5

Maximum breaking current 5V_{DC} / 80A (100 cycles)
Contact Rating 9V_{DC} / 25A (6000 cycles)

Table M2 – Electrical Characteristics for MHP-TAM6 Series

Model Number	Rating [°C] Nominal	Operation Temperature [°C]		Reset Temperature [°C]		Reference Resistance [mohms] 25°C	
		Min	Max	Min	ΔT	Typ	Max
MHP-TAM6-9-72	72	67	77	≥40	≥7	10	15
MHP-TAM6-9-77	77	72	82	≥40	≥10	10	15
MHP-TAM6-9-82	82	77	87	≥40	≥10	10	15
MHP-TAM6-9-85	85	80	90	≥40	≥10	10	15

Maximum breaking current 5V_{DC} / 40A (100 cycles)
Contact Rating 9V_{DC} / 12A (6000 cycles)
ΔT is the minimum temperature differential between the actual operation temperature of the device and the reset temperature

Table M3 – Dimensions in Millimeters and Mechanical Characteristics

	A		B	C		D		E	
	Min	Max	Max	Min	Max	Min	Max	Min	Max
mm:	10.9	11.4	1.15	3.75	3.85	2.6	2.8	2.6	2.8

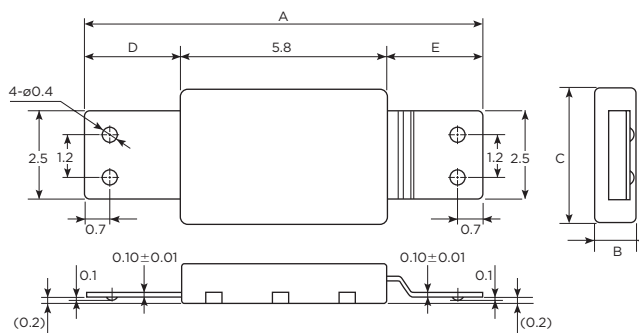

MHP-TAM Devices: MHP with Thermal Activation

Figures M1-M2 — Hold Current vs. Temperature Curves (Typical)

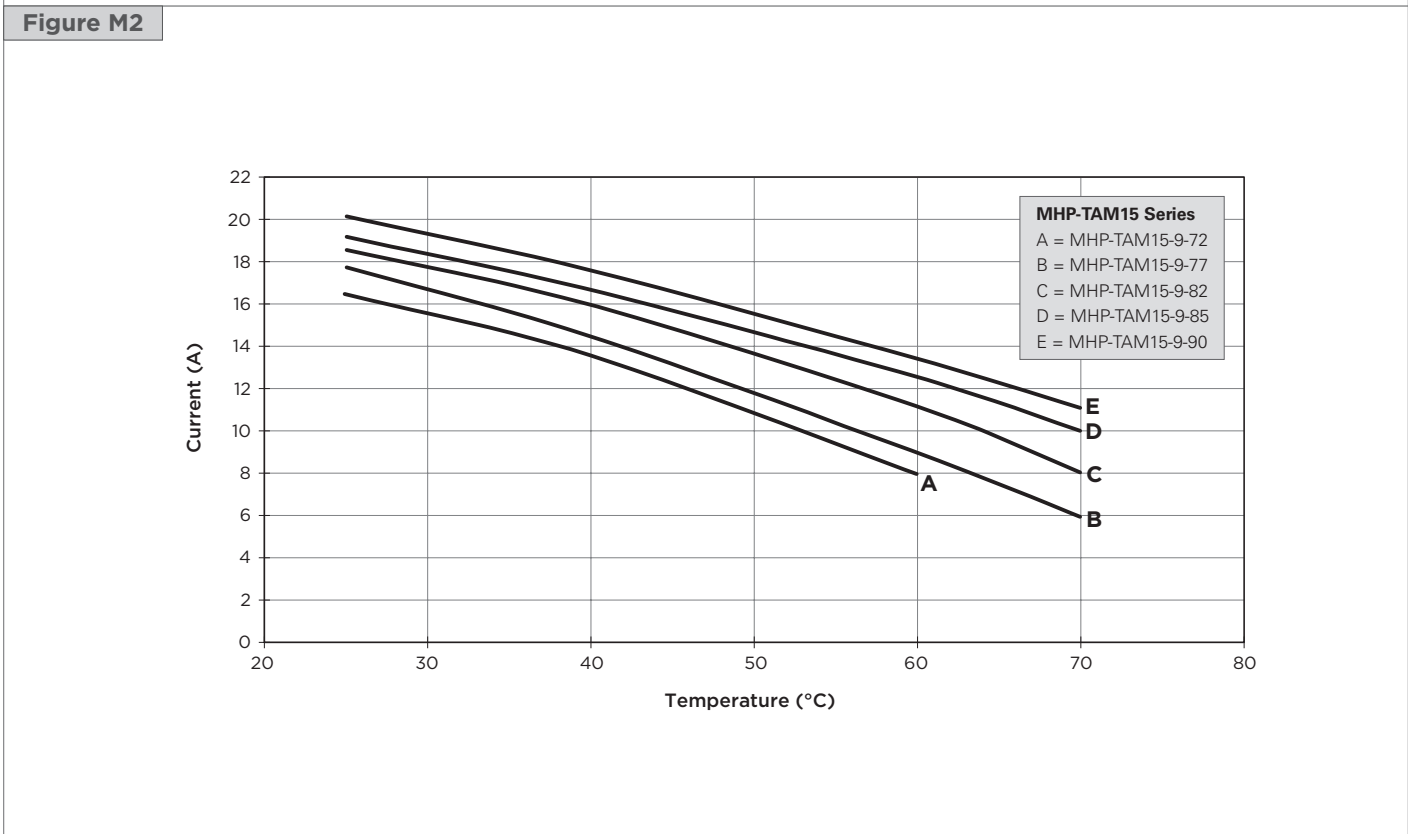
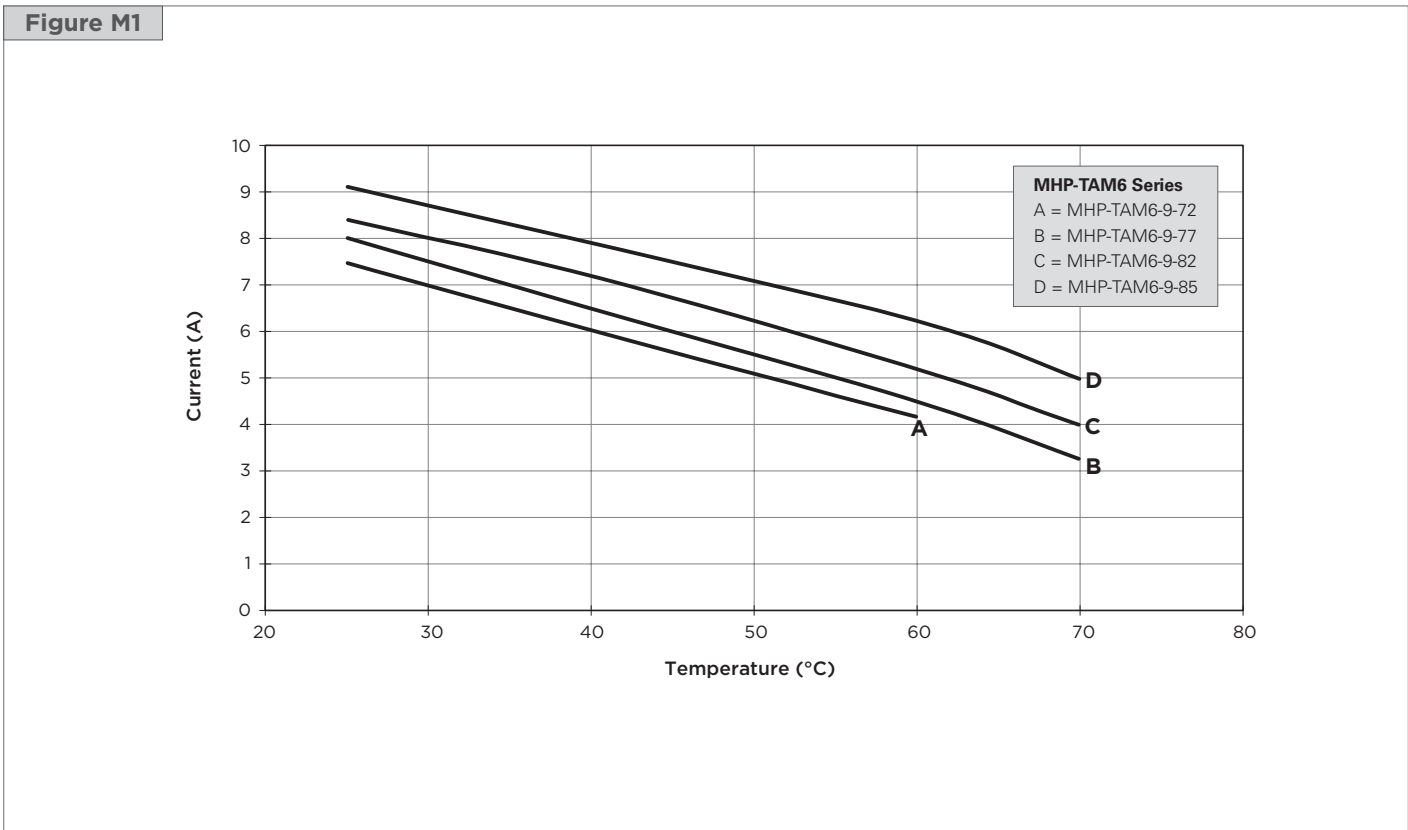

MHP-TAM Devices: MHP with Thermal Activation

Physical Characteristics

Terminals	Copper Alloy
Molding Plastic	LCP (Liquid Crystal Polymer)

RoHS and Halogen-Free Compliance

RoHS Compliant
Halogen Free per IEC 61249-2-21

Storage Conditions

Device must be stored in the original, unopened bag.
Suggested storage temperature (except for packaging material)
Temperature: -10°C – 40°C
Humidity: 75%RH (max)

The following environments should be avoided for storage:
Areas with salt air or with corrosive gas, such as Cl₂, H₂S, NH₃, SO₂ and NO_x.
Areas exposed to direct sunlight.
Areas outside of the suggested storage temperature range, as indicated above.

Precautions for Handling

The device is composed of plastic parts, please do not clamp or dent the housing with a tool as this might cause a resistance increase and product damage.

When welding product terminals or mounting the breaker on a battery (cell), please be careful not to apply excessive bending, twisting or force on the product and terminals. The excessive stress might cause a resistance increase or product damage.

Please refer to following cautions:

1. Do not apply more than 10N bend force to product. (Fig. M3)
2. Do not apply more than 1.5cN/m twist torque to the product. (Fig. M4)
3. Do not apply more than 20N deflection force to product. (Fig. M5)
4. Do not apply more than 2N force to the terminals. (Fig. M6)
5. Do not apply more than 0.6cN/m twisting torque to the terminals. (Fig. M7)
6. Do not bend the terminal base more than 45° when the product is mounted in a fixed position. (Fig. M8)

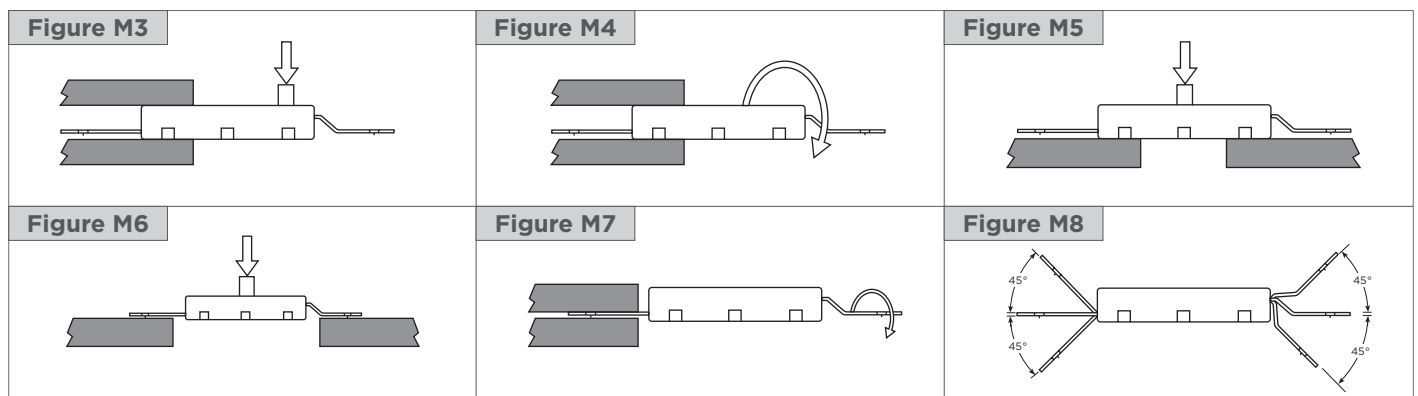

Product terminals can be welded using direct welding and series welding methods. In either case, please use a suitable jig so that the device will not be subjected to the stress conditions listed above.

Pull strength and detach strength of the terminal welds are per user requirements. However, if the welding is controlled by resistance, the measurement should be made as close as possible to the weld point by a "4-point clip method" using milliohm meter to ensure accuracy.

Avoid putting stress on the device, as listed above, when a jig, fitting or additional welding process is used. Please reconfirm the resistance value whenever a new process is added.

MHP-TAM Devices: MHP with Thermal Activation

Table M4 — Packaging and Marking Information

Part Number	Bag Quantity	T & R Quantity	Standard Package	Part Marking	Agency Recognition
MHP-TAM 15 Series					
MHP-TAM15-9-72	1,000	—	20,000	Lot ID#, Control# & Co. Logo, Product #	UL & cUL File No. E349829; CB File No. US-24160-UL
MHP-TAM15-9-77	1,000	—	20,000	Lot ID#, Control# & Co. Logo, Product #	UL & cUL File No. E349829; CB File No. US-24160-UL
MHP-TAM15-9-82	1,000	—	20,000	Lot ID#, Control# & Co. Logo, Product #	UL & cUL File No. E349829; CB File No. US-24160-UL
MHP-TAM15-9-85	1,000	—	20,000	Lot ID#, Control# & Co. Logo, Product #	UL & cUL File No. E349829; CB File No. US-24160-UL
MHP-TAM15-9-90	1,000	—	20,000	Lot ID#, Control# & Co. Logo, Product #	UL & cUL File No. E349829; CB File No. US-24160-UL
MHP-TAM 6 Series					
MHP-TAM6-9-72	1,000	—	20,000	Lot ID#, Control# & Co. Logo, Product #	UL & cUL File No. E349829; CB File No. US-23966-M1-UL
MHP-TAM6-9-77	1,000	—	20,000	Lot ID#, Control# & Co. Logo, Product #	UL & cUL File No. E349829; CB File No. US-23966-M1-UL
MHP-TAM6-9-82	1,000	—	20,000	Lot ID#, Control# & Co. Logo, Product #	UL & cUL File No. E349829; CB File No. US-23966-M1-UL
MHP-TAM6-9-85	1,000	—	20,000	Lot ID#, Control# & Co. Logo, Product #	UL & cUL File No. E349829; CB File No. US-23966-M1-UL

Table M5 — Ordering Information

Bag	1,000	pieces
Box	20,000	pieces

MHP-TAM Devices: MHP with Thermal Activation

Part Numbering System

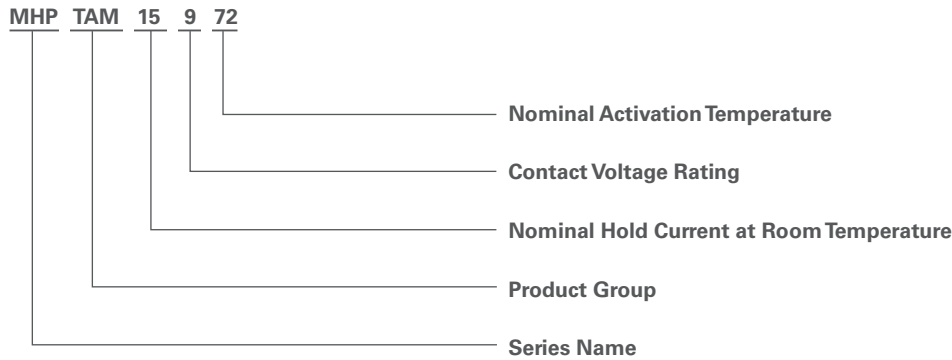

Notice:

Littelfuse products are not designed for, and shall not be used for, any purpose (including, without limitation, automotive, military, aerospace, medical, life-saving, life-sustaining or nuclear facility applications, devices intended for surgical implant into the body, or any other application in which the failure or lack of desired operation of the product may result in personal injury, death, or property damage) other than those expressly set forth in applicable Littelfuse product documentation. Warranties granted by Littelfuse shall be deemed void for products used for any purpose not expressly set forth in applicable Littelfuse documentation. Littelfuse shall not be liable for any claims or damages arising out of products used in applications not expressly intended by Littelfuse as set forth in applicable Littelfuse documentation. The sale and use of Littelfuse products is subject to Littelfuse Terms and Conditions of Sale, unless otherwise agreed by Littelfuse.

Special Recommendations:

1. The power supply voltage must be less than the rated voltage of the device. Operation above the voltage rating may result in device damage, smoking or flame.
2. Designs must be selected in such a manner that the device hold current is higher than the normal current value in the circuit and that the device trip current is lower than the abnormal current value. Selecting device hold current and trip current values that are too low for the application may interrupt the circuit under normal usage conditions.
3. This product should not be used in an application where the maximum interrupt current can be exceeded in a short circuit condition.
4. The devices are intended for protection against damage caused by occasional overcurrent or overtemperature fault conditions and should not be used when repeated fault conditions or prolonged trip events are anticipated.
5. The devices may not perform as specified if mechanical pressure is added while the device is in the tripped state or exposed to temperature conditions lower than -30°C or over 100°C .

X-ON Electronics

Largest Supplier of Electrical and Electronic Components

Click to view similar products for [Thermal Cut-offs](#) category:

Click to view products by [Littelfuse](#) manufacturer:

Other Similar products are found below :

[D070-002](#) [HC77AY-B](#) [SDF DF192S](#) [SDF DF152S](#) [TT125](#) [TT86](#) [X2](#) [Y1](#) [F18](#) [Q136](#) [P125](#) [C7](#) [RS240](#) [RS257](#) [H18](#) [R7](#) [RS167](#) [TT102](#) [B13](#)
[X3](#) [C32](#) [Y0](#) [K9](#) [K8](#) [V0](#) [S136](#) [X8](#) [RS104](#) [RS117](#) [RT121](#) [U2](#) [RT167](#) [SDF DF144S](#) [HP136](#) [K5](#) [RT117](#) [H7](#) [RS128](#) [H5](#) [RT99](#) [RT128](#) [X32](#)
[RS72](#) [U5](#) [R3](#) [H6](#) [RS121](#) [RS152](#) [V2](#) [R6](#)