

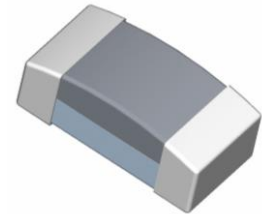
## Specification Status: Released

### BENEFITS

- ESD protection for high frequency applications (HDMI 1.3)
- Smaller form factor for board space savings
- Helps protect electronic circuits against damage from electrostatic discharge (ESD) events
- Assists equipment to pass IEC 61000-4-2, level 4 testing

### FEATURES

- 0.25 pF (typ) Capacitance
- Low leakage current
- Low clamping voltage
- Fast response time (<1ns)
- Capable of withstanding numerous ESD strikes
- Compatible with standard reflow installation procedures
- Thick film technology
- Bi-directional protection



### APPLICATIONS

- HDMI 1.3 interface
- LCD, HDTV
- Cellular phones
- Antennas (cell phones, GPS...)
- Portable video devices (PDA, DSC, Bluetooth...)
- Printer ports
- High speed Ethernet
- USB 2.0 and IEEE 1394 interfaces
- DVI interface

**CAUTION:** This device should not be used in Power Bus applications

### MATERIALS INFORMATION

**RoHS Compliant**

Directive 2002/95/EC  
Compliant

**ELV Compliant**

Directive 2000/53/EC  
Compliant

**Halogen Free\***



**Lead-free**



### PART NUMBERING

|          |             |             |   |            |  |
|----------|-------------|-------------|---|------------|--|
|          | <u>PESD</u> | <u>0402</u> | - | <u>140</u> |  |
| Series   |             |             |   |            |  |
| EIA Size |             |             |   |            |  |

**Operating Voltage Designator**  
14 x 10<sup>0</sup> = 14V<sub>DC</sub>

\* Halogen Free refers to: Br≤900ppm, Cl≤900ppm, Br+Cl≤1500pp

## TYPICAL DEVICE RATINGS AND CHARACTERISTICS

|        | Continuous Max Operating Voltage | Typical TLP Trigger Voltage <sup>1</sup> | Typical TLP Clamping Voltage <sup>1</sup> after 30ns | Typical Capacitance <sup>2</sup> @ 1 MHz, 1V <sub>rms</sub> | Typical Leakage Current @ 14V <sub>DC</sub> | Max Leakage Current @ 14V <sub>DC</sub> |
|--------|----------------------------------|--|--|---|---|---|
| Symbol | V <sub>DC</sub>                  | V <sub>T(TLP)</sub>                      | V <sub>C(TLP 30)</sub>                               | C <sub>p</sub>  | I <sub>L(Typ)</sub>                         | I <sub>L(MAX)</sub>                     |
| Unit   | V                                | V  | V  | pF  | μA  | μA                                      |
| Value  | 14                               | 250                                      | 40   | 0.25  | <0.01                                       | 10.0                                    |

Note 1: TLP test method at 1000V (refer to FIG. 5 on page 5)

Note 2: Typical capacitance @ 0V and 14V bias

## GENERAL CHARACTERISTICS

Operating temperature: -55°C to +125°C

Storage temperature: -55°C to +125°C

ESD voltage capability (tested per IEC 61000-4-2)

- Contact discharge mode: 8kV (typ), 15kV (max)
- Air discharge mode: 15kV (typ), 25kV (max) [1 pulse: per customer request]

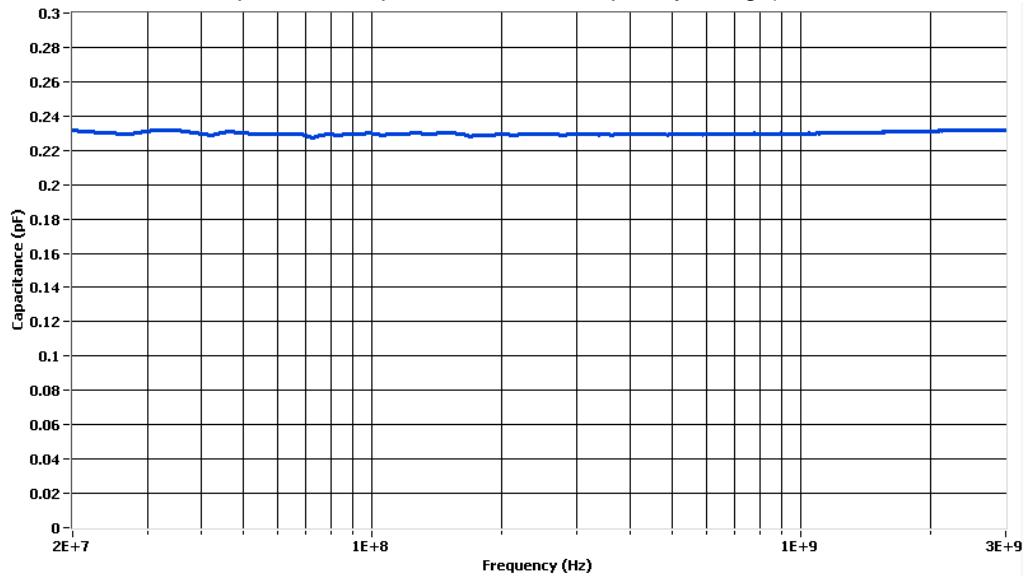
ESD pulse withstand: Typically 100 pulses (tested per IEC 61000-4-2, level 4, and contact method)

## Environmental Specifications

|                    | Bias Humidity Test  | Thermal Shock                                | Bias Heat Test                                 | Bias Low Temp Test                             | Solderability                | Solder Heat  | Vibration   | Mechanical Shock                             | Solvent Resistance                           |
|--------------------|---|--|--|--|------------------------------|--------------|---|--|--|
| Test Conditions    | @ 85°C<br>@ 85% RH<br>V <sub>DC</sub> (max)<br>1000 hours | -55°C to 125°C<br>30min dwell<br>1000 cycles | @ 125°C<br>V <sub>DC</sub> (max)<br>1000 hours | @ -55°C<br>V <sub>DC</sub> (max)<br>1000 hours | 250 °C +/- 5 °C<br>3s +/- 1s | 260 °C, 10s  | 10 to 50Hz,<br>60s cycle,<br>2hrs each in<br>X-Y-Z axis | 1500G,<br>0.5ms, X-Y-Z<br>axis<br>3<br>times | IPA ultrasonic<br>300s                       |
| Pass/Fail Criteria | I <sub>L</sub> ≤ 10μA                                     | I <sub>L</sub> ≤ 10μA                        | I <sub>L</sub> ≤ 10μA                          | I <sub>L</sub> ≤ 10μA                          | 95% coverage                 | 90% coverage | No Physical Damage<br>I <sub>L</sub> ≤ 10 μA            | No Physical Damage<br>I <sub>L</sub> ≤ 10 μA | No Physical Damage<br>I <sub>L</sub> ≤ 10 μA |

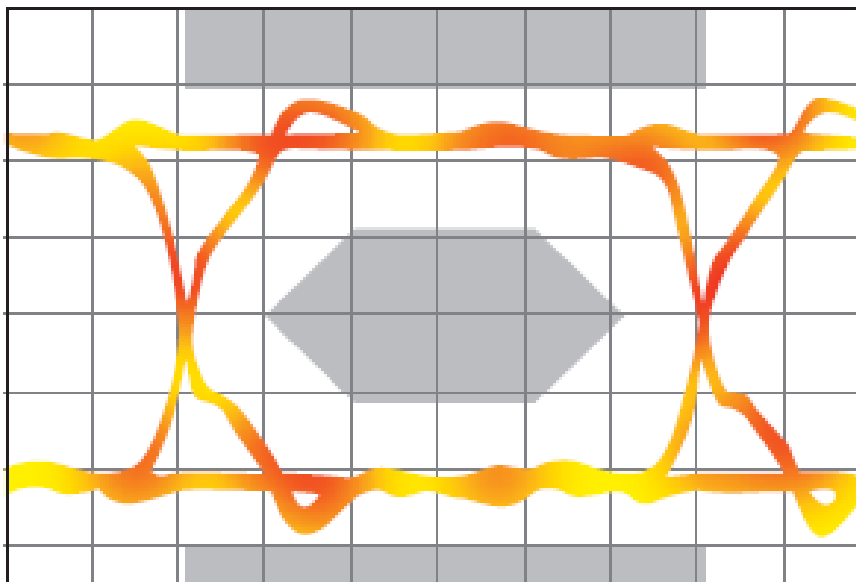
**FIG 1: CAPACITANCE VS. FREQUENCY (TYPICAL SAMPLE)**

(PESD0402 Flat Response of Capacitance over Frequency Range)

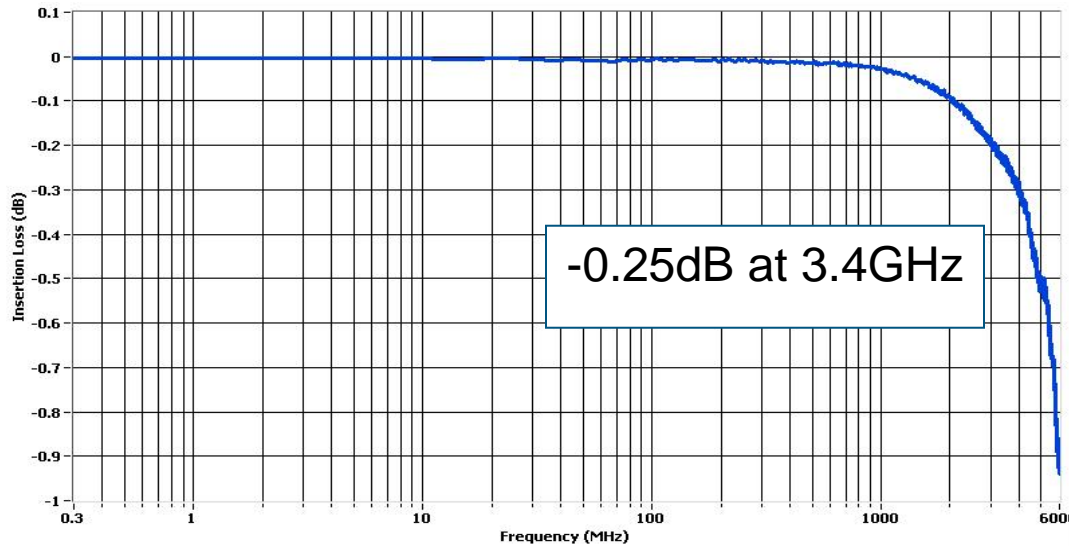


**FIG 2: EYE DIAGRAM (TYPICAL SAMPLE)**

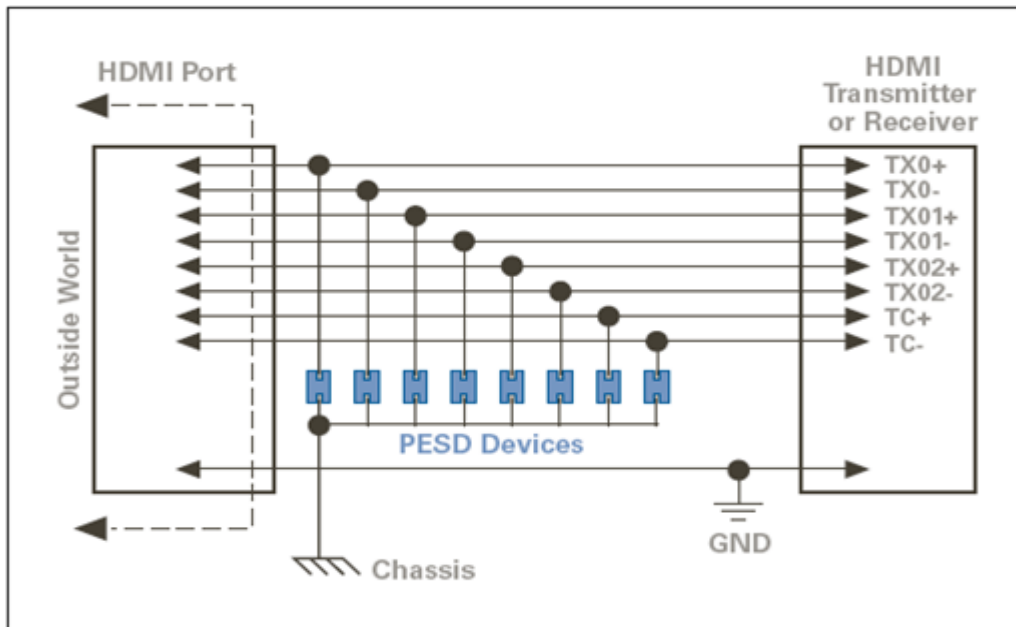
(PESD0402 Eye Diagram Performance at 3.4 GHz— meets criteria for HDMI 1.3)



**FIG 3: INSERTION LOSS DIAGRAM (TYPICAL SAMPLE)**  
 (PESD0402 Minimal Insertion Loss at 3.4 GHz)

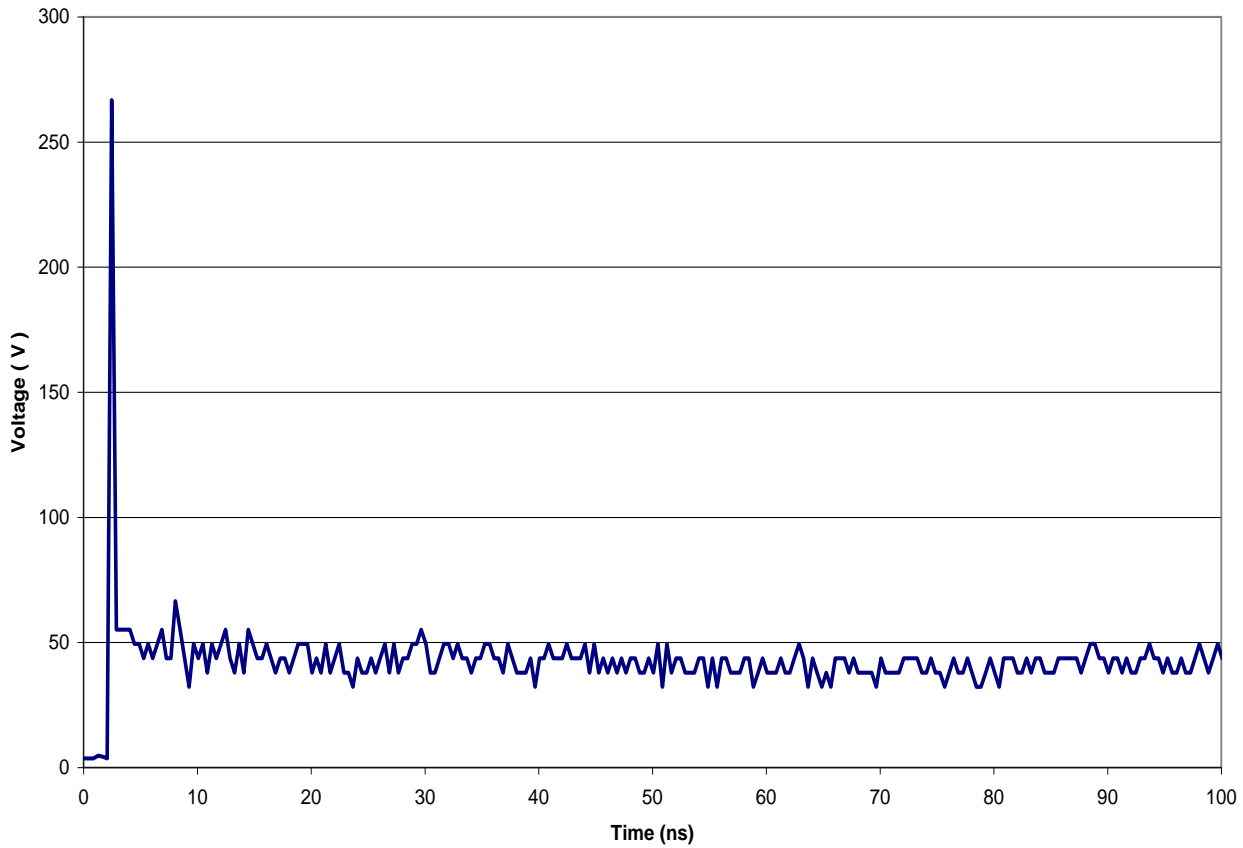


**FIG 4: ESD PROTECTION FOR HDMI**  
 (PESD0402 Reference Layout and Test Results available)

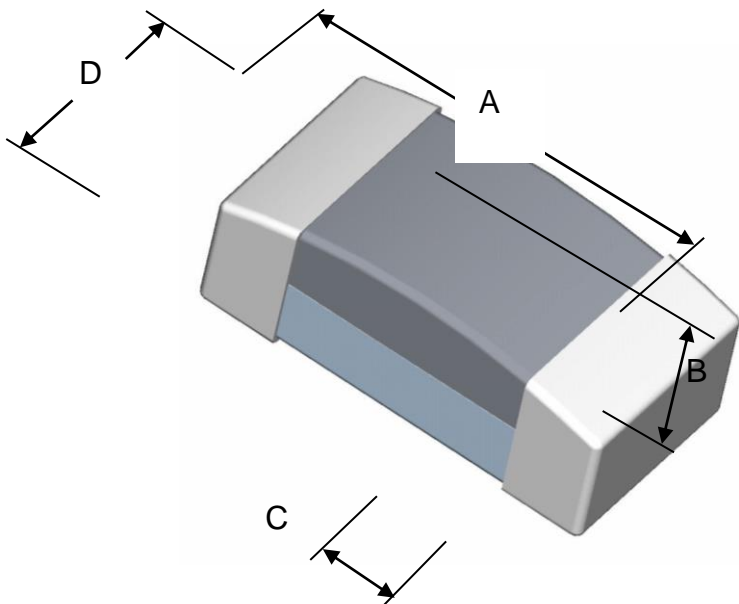


**FIG 5: TYPICAL TRANSMISSION LINE PULSE RESPONSE GRAPH**

Typical TLP Clamping Voltage



**DIMENSIONS**



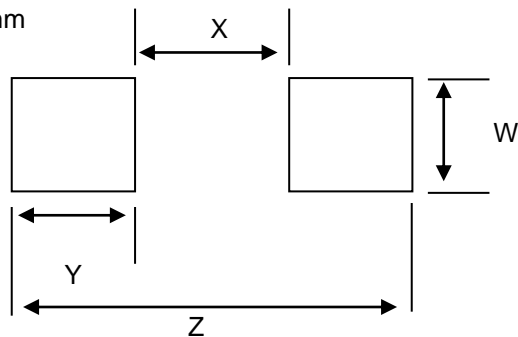
Drawing Not To Scale

|     | Length A |         | Height B |         | Terminal Width C |         | Width D |         |
|-----|----------|---------|----------|---------|------------------|---------|---------|---------|
|     | Min      | Max     | Min      | Max     | Min              | Max     | Min     | Max     |
| mm  | 0.90     | 1.10    | 0.23     | 0.43    | 0.10             | 0.30    | 0.40    | 0.60    |
| in* | (0.035)  | (0.043) | (0.009)  | (0.017) | (0.004)          | (0.012) | (0.016) | (0.024) |

\* Round off approximation

**RECOMMENDED LAND PATTERN:**

Solder thickness 0.15 to 0.2mm

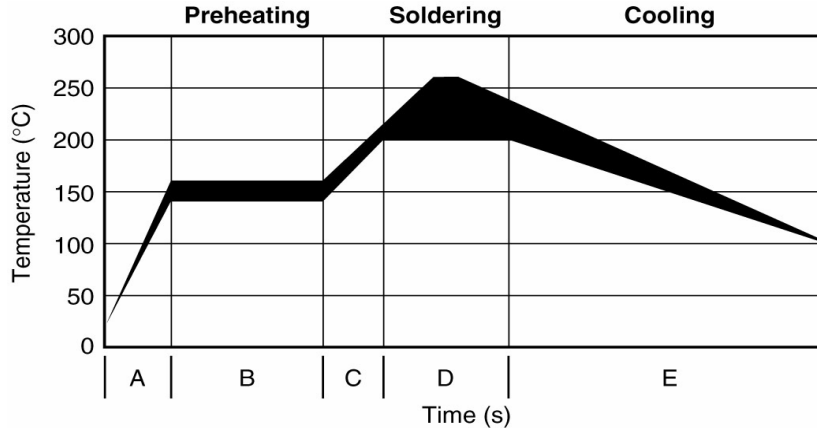


|     | W       |         | X       |         | Y       |         | Z       |         |
|-----|---------|---------|---------|---------|---------|---------|---------|---------|
|     | Min     | Max     | Min     | Max     | Min     | Max     | Min     | Max     |
| mm  | 0.60    | 0.70    | 0.30    | 0.40    | 0.80    | 0.90    | 2.10    | 2.20    |
| in* | (0.024) | (0.028) | (0.012) | (0.016) | (0.031) | (0.035) | (0.083) | (0.087) |

\* Round off approximation

**SOLDER REFLOW RECOMMENDATIONS:**

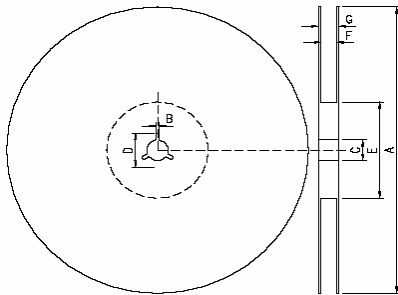
|   |                       |  |   |
|---|-----------------------|--|---|
| A | Temperature ramp up 1 | From ambient to Preheating temperature       | 30s to 60s                                      |
| B | Preheating            | 140°C - 160°C                                | 60s to 120s                                     |
| C | Temperature ramp up 2 | From Preheating to Main heating temperature  | 20s to 40s                                      |
| D | Main heating          | at 200°C<br>at 220°C<br>at 240°C<br>at 260°C | 60s ~ 70s<br>50s ~ 60s<br>30s ~ 40s<br>5s ~ 10s |
| E | Cooling               | From main heating temperature to 100°C       | 4°C/s (max)                                     |



**PACKAGING**

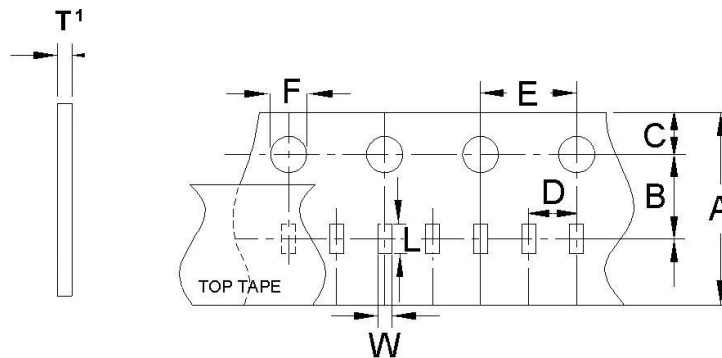
| Packaging    | Tape & Reel | Standard Box |
|--------------|-------------|--------------|
| PESD0402-140 | 10,000      | 50,000       |

**EIA referenced Reel Dimensions for PESD Devices**



**Reel Dimensions (mm):**

|                     | A          | B        | C         | D         | E         | F        | G         |
|---------------------|------------|----------|-----------|-----------|-----------|----------|-----------|
| <b>0402 Devices</b> | 178.0 ±2.0 | 2.0 ±0.5 | 13.0 ±0.5 | 21.0 ±0.8 | 62.0 ±1.5 | 9.0 ±0.5 | 13.0 ±1.0 |



**Carrier**

**Dimensions (mm):**

|                     | A          | B          | C          | D          | E          | F          | L          | W          | T <sup>1</sup> |
|---------------------|------------|------------|------------|------------|------------|------------|------------|------------|----------------|
| <b>0402 Devices</b> | 8.00 ±0.30 | 3.50 ±0.05 | 1.75 ±0.10 | 2.00 ±0.05 | 4.00 ±0.10 | 1.50 ±0.10 | 1.13 ±0.03 | 0.63 ±0.03 | 0.48 ±0.03     |

Note 1: Carrier thickness

**Product Orientation** – always face up (meaning the substrate is at the bottom), but parts do not have polarity mark.

**Leader & Trailer:** The leader is 180mm in length & consists of empty cavities with sealed cover tape. The trailer is 350mm in length & consists of empty cavities with sealed cover tape.



## POST REFLOW, CLEANING CONDITIONS

A 5% saponifier combined with water during wash.

For the ultrasonic process water temperature should be at 50°C and board should be submerged for a minimum of one minute in the solutions, then rinse and dry.

For in-line washing, the temperature of the water sprayed should be at 110°C, rinse and drying is done in-line.



**Warning: Application Limitations for PESD0402-140. This part is not intended to be used on power lines or for power bus applications. Users should independently evaluate the suitability of and test each product selected for their own applications**

Information furnished is believed to be accurate and reliable. However, users should independently evaluate the suitability of and test each product selected for their own applications. Littelfuse products are not designed for, and shall not be used for, any purpose (including, without limitation, military, aerospace, medical, lifesaving, life-sustaining or nuclear facility applications, devices intended for surgical implant into the body, or any other application in which the failure or lack of desired operation of the product may result in personal injury, death, or property damage) other than those expressly set forth in applicable Littelfuse product documentation. Warranties granted by Littelfuse shall be deemed void for products used for any purpose not expressly set forth in applicable Littelfuse documentation. Littelfuse shall not be liable for any claims or damages arising out of products used in applications not expressly intended by Littelfuse as set forth in applicable Littelfuse documentation. The sale and use of Littelfuse products is subject to Littelfuse Terms and Conditions of Sale, unless otherwise agreed by Littelfuse.

## X-ON Electronics

Largest Supplier of Electrical and Electronic Components

*Click to view similar products for [ESD Suppressors / TVS Diodes](#) category:*

*Click to view products by [Littelfuse](#) manufacturer:*

Other Similar products are found below :

[60KS200C](#) [D12V0H1U2WS-7](#) [D18V0L1B2LP-7B](#) [82356050220](#) [D5V0F4U5P5-7](#) [D5V0M5U6V-7](#) [NTE4902](#) [P4KE27CA](#) [P6KE11CA](#)  
[P6KE39CA-TP](#) [P6KE8.2A](#) [SA110CA](#) [SA60CA](#) [SA64CA](#) [SMBJ12CATR](#) [SMBJ8.0A](#) [SMLJ30CA-TP](#) [ESD112-B1-02EL E6327](#)  
[ESD119B1W01005E6327XTSA1](#) [ESD5V0J4-TP](#) [ESD5V0L1B02VH6327XTSA1](#) [ESD7451N2T5G](#) [19180-510](#) [CPDT-5V0USP-HF](#)  
[3.0SMCJ33CA-F](#) [3.0SMCJ36A-F](#) [HSPC16701B02TP](#) [D3V3Q1B2DLP3-7](#) [D55V0M1B2WS-7](#) [DESD5V0U1BL-7B](#) [DRTR5V0U4SL-7](#)  
[SCM1293A-04SO](#) [ESD203-B1-02EL E6327](#) [SM12-7](#) [SMF8.0A-TP](#) [SMLJ45CA-TP](#) [CEN955 W/DATA](#) [82350120560](#) [82356240030](#)  
[VESD12A1A-HD1-GS08](#) [CPDUR5V0R-HF](#) [CPDUR24V-HF](#) [CPDQC5V0U-HF](#) [CPDQC5V0USP-HF](#) [CPDQC5V0-HF](#) [D1213A-01LP4-7B](#)  
[D1213A-02WL-7](#) [ESDLIN1524BJ-HQ](#) [5KP100A](#) [5KP15A](#)