

QJxx25xHx Series

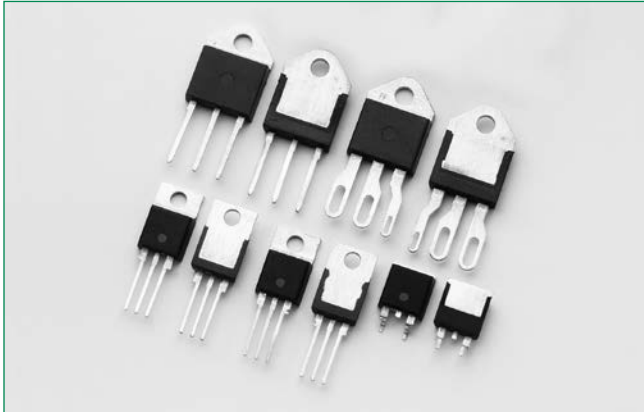

Description

This 25A alternistor triac solid state switch series is designed for AC switching and phase control applications such as motor speed and temperature modulation controls, lighting controls, and static switching relays.

Standard alternistor triac components operate with in-phase signals in quadrants I or III and only unipolar negative gate pulses for quadrant II or III. The alternistor triac will not operate in quadrant IV.

Agency Approvals

Agency	Agency File Number
	E71639*

* - J, K and L Packages

Features & Benefits

- Voltage capability up to 600V
- Surge capability of 250A at 60Hz half cycle
- Halogen free and RoHS compliant
- Recognized to UL 1557

Main Features

Symbol	Value	Unit
$I_{T(RMS)}$	25	A
V_{DRM}/V_{RRM}	400, 600, or 800	V
I_{GT}	35 to 80	mA

Schematic Symbol

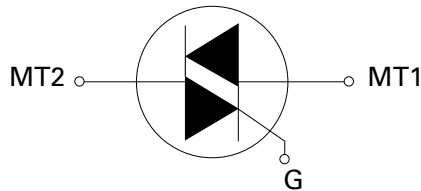

Applications

Excellent for AC switching and phase control applications such as heating, lighting, and motor speed controls.

Typical applications are AC solid-state switches, industrial power tools, exercise equipment, white goods and commercial appliances.

Alternistor Triacs (no snubber required) are used in applications with high inductive loads requiring the highest commutation performance.

Isolated packages offered for ease of heat sinking.

Absolute Maximum Ratings – Alternistor Triac

Symbol	Parameter	Test Conditions	Value	Unit
$I_{T(RMS)}$	RMS on-state current	QJxx25LHy $T_C = 90^\circ\text{C}$	25	A
		QJxx25KH6 QJxx25JH6 $T_C = 110^\circ\text{C}$		
		QJxx25RHy QJxx25NHy $T_C = 120^\circ\text{C}$		
I_{TSM}	Peak non-repetitive surge current	Single half cycle; $f = 50\text{Hz}$; T_J (initial) = 25°C	208	A
		Single half cycle; $f = 60\text{Hz}$; T_J (initial) = 25°C	250	
I^2t	I^2t Value for fusing	$t_p = 8.3\text{ms}$	260	A^2s
di/dt	Critical rate-of-rise of on-state current	$f = 60\text{Hz}$; $T_J = 150^\circ\text{C}$	100	$\text{A}/\mu\text{s}$
I_{GTM}	Peak gate current	$t_p = 20\mu\text{s}$, $T_J = 150^\circ\text{C}$	4	A
$P_{G(AV)}$	Average gate power dissipation	$T_J = 150^\circ\text{C}$	0.5	W
T_{stg}	Storage temperature range		-40 to 150	$^\circ\text{C}$
T_J	Operating junction temperature range		-40 to 150	$^\circ\text{C}$
V_{DSM}/V_{RSM}	Peak non-repetitive blocking voltage	$P_w = 100 \mu\text{s}$	$V_{DRM}/V_{RRM} + 100$	V

xx = voltage/10

Electrical Characteristics ($T_J = 25^\circ\text{C}$, unless otherwise specified) – Alternistor Triac

Symbol	Test Conditions	Quadrant		Value			Unit
				QJxx25xH4	QJxx25xH5	QJxx25xH6	
I_{GT}	$V_D = 12\text{V}$; $R_L = 60\Omega$	I – II – III	MAX.	35	50	80	mA
V_{GT}		I – II – III	MAX.	1.3			V
V_{GD}	$V_D = V_{DRM}$; $R_L = 3.3\text{k}\Omega$; $T_J = 150^\circ\text{C}$	I – II – III	MIN.	0.15			V
I_H	$I_T = 400\text{mA}$ (initial)		MAX.	50	50	100	mA
dv/dt	$V_D = V_{DRM}$; Gate Open; $T_J = 150^\circ\text{C}$	400V	MIN.	-	575	600	$\text{V}/\mu\text{s}$
		600V 800V		- 350	500 450	600	
$(dv/dt)_c$	$(di/dt)_c = 13.3 \text{A/ms}$; $T_J = 150^\circ\text{C}$		MIN.	15	20	30	$\text{V}/\mu\text{s}$
t_{gt}	$I_G = 2 \times I_{GT}$; $PW = 15\mu\text{s}$; $I_T = 35.4\text{A}$		TYP.	3	3	5	μs

Static Characteristics

Symbol	Test Conditions		Value	Unit
V_{TM}	$I_T = 35.4\text{A}$; $t_p = 380 \mu\text{s}$		MAX. 1.8	V
I_{DRM}/I_{RRM}	V_{DRM}/V_{RRM}	$T_J = 25^\circ\text{C}$	MAX. 4000	μA
		$T_J = 125^\circ\text{C}$		
		$T_J = 150^\circ\text{C}$		

xx = voltage/10, x = package

Thermal Resistances

Symbol	Parameter	Value	Unit	
$R_{\theta(J-C)}$	Junction to case (AC)	QJxx25RH6 / QJxx25NH6 QJxx25RH5 / QJxx25NH5	0.90	°C/W
		QJxx25LH6 / QJxx25LH5	1.80	
		QJxx25KH6 / QJxx25JH6	1.25	
		QJxx25RHy	45	
$R_{\theta(J-A)}$	Junction to ambient	QJxx25RH6 / QJxx25LH5	50	°C/W

xx = voltage/10, y = sensitivity

Figure 1: Normalized DC Gate Trigger Current vs. Junction Temperature

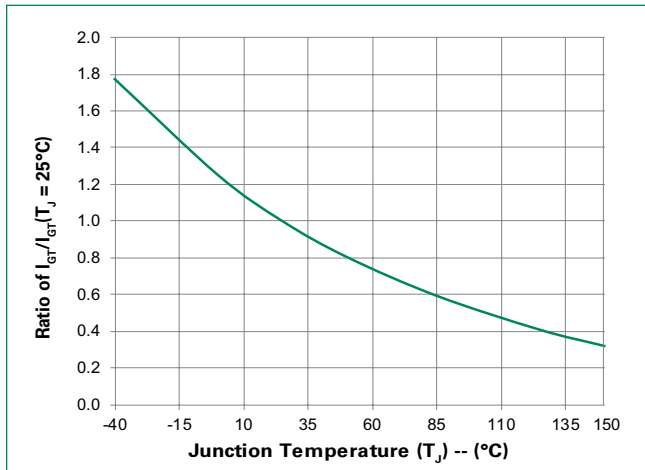

Figure 2: Normalized DC Gate Trigger Voltage vs. Junction Temperature

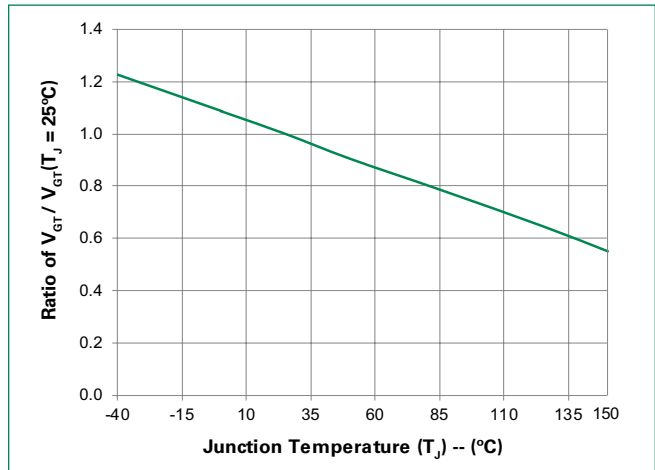

Figure 3: Normalized DC Holding Current vs. Junction Temperature

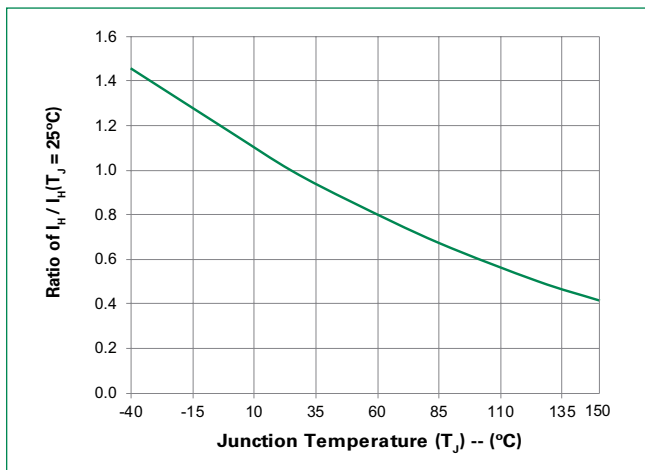

Figure 4: On-State Current vs. On-State Voltage (Typical)

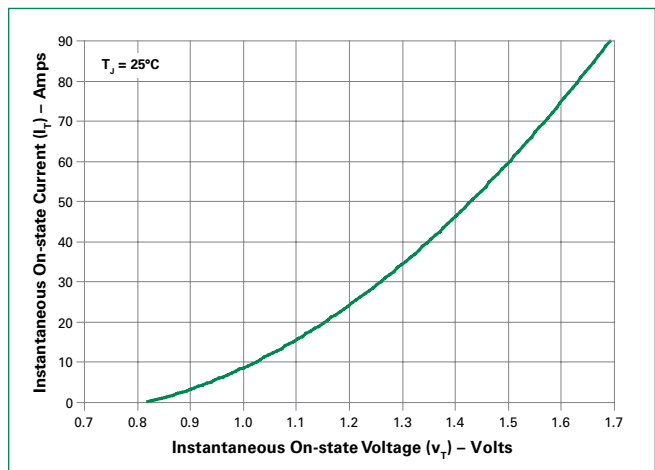

Figure 5: Power Dissipation (Typical) vs. RMS On-State Current

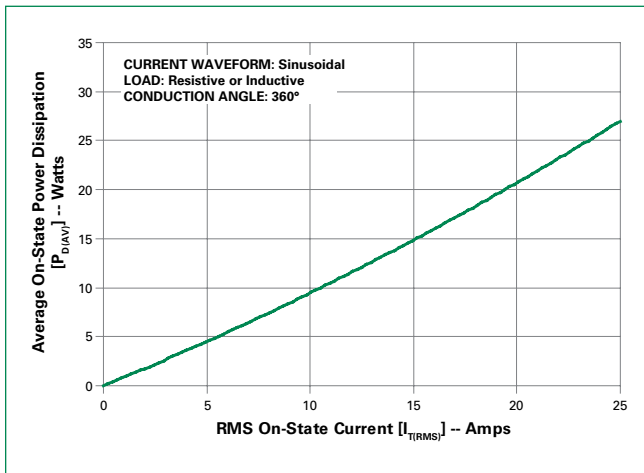

Figure 6: Maximum Allowable Case Temperature vs. RMS On-State Current

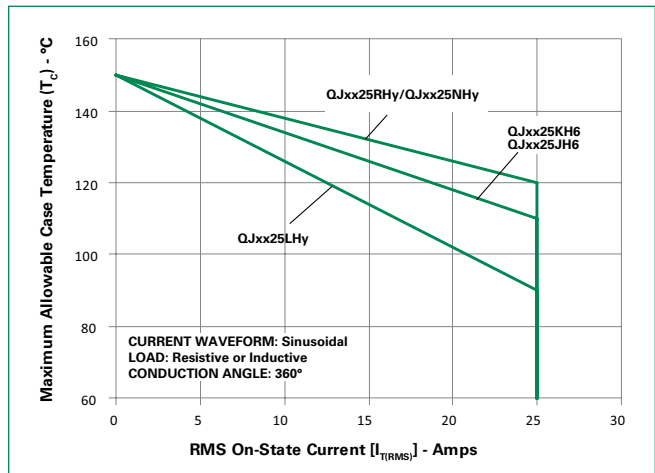
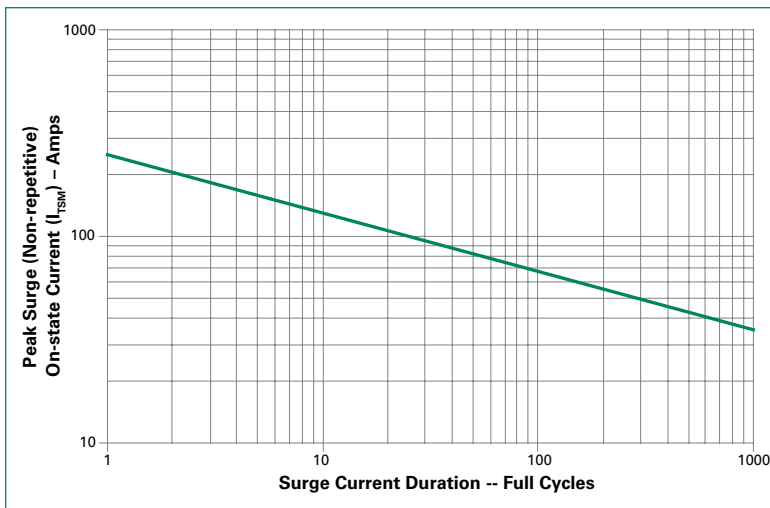

Figure 8: Surge Peak On-State Current vs. Number of Cycles



SUPPLY FREQUENCY: 60 Hz Sinusoidal
LOAD: Resistive
RMS On-State Current: [I_{T(RMS)}]: Maximum Rated Value at Specified Case Temperature

- Notes:
1. Gate control may be lost during and immediately following surge current interval.
 2. Overload may not be repeated until junction temperature has returned to steady-state rated value.

Soldering Parameters

Reflow Condition		Pb - Free assembly
Pre Heat	- Temperature Min ($T_{s(min)}$)	150°C
	- Temperature Max ($T_{s(max)}$)	200°C
	- Time (min to max) (t_s)	60 - 180 secs
Average ramp up rate (Liquidus Temp) (T_L) to peak		5°C/second max
$T_{S(max)}$ to T_L - Ramp-up Rate		5°C/second max
Reflow	- Temperature (T_L) (Liquidus)	217°C
	- Temperature (t_t)	60 - 150 seconds
Peak Temperature (T_p)		260 ^{+0/-5} °C
Time within 5°C of actual peak Temperature (t_p)		20 - 40 seconds
Ramp-down Rate		5°C/second max
Time 25°C to peak Temperature (T_p)		8 minutes Max.
Do not exceed		280°C

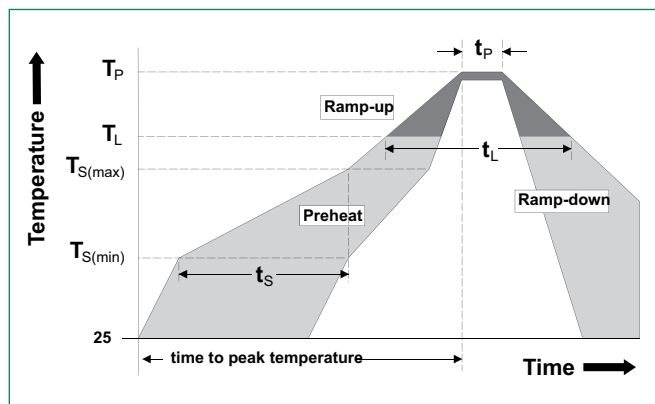

Physical Specifications

Terminal Finish	100% Matte Tin-plated
Body Material	UL Recognized compound meeting flammability rating V-0
Lead Material	Copper Alloy

Design Considerations

Careful selection of the correct component for the application's operating parameters and environment will go a long way toward extending the operating life of the Thyristor. Good design practice should limit the maximum continuous current through the main terminals to 75% of the component rating. Other ways to ensure long life for a power discrete semiconductor are proper heat sinking and selection of voltage ratings for worst case conditions. Overheating, overvoltage (including dv/dt), and surge currents are the main killers of semiconductors. Correct mounting, soldering, and forming of the leads also help protect against component damage.

Environmental Specifications

Test	Specifications and Conditions
High Temperature Voltage Blocking	MIL-STD-750: Method 1040, Condition A Rated V_{RRM} , 150°C, 1008 hours
Temperature Cycling	MIL-STD-750: Method 1051 -40°C to 150°C, 15-minute dwell, 100 cycles
Biased Temp & Humidity	EIA/JEDEC: JESD22-A101 320VDC, 85°C, 85%RH, 1008 hours
High Temp. Storage	MIL-STD-750: Method 1031 150°C, 1008 hours
Low-Temp Storage	-40°C, 1008 hours
Resistance to Solder Heat	MIL-STD-750: Method 2031 260°C, 10 seconds
Solderability	ANSI/J-STD-002, Category 3, Test A
Lead Bend	MIL-STD-750: Method 2036, Condition E
Moisture Sensitivity Level	Level 1, JEDEC-J-STD-020

Dimensions – TO-220AB (R Package) – Non-isolated Mounting Tab

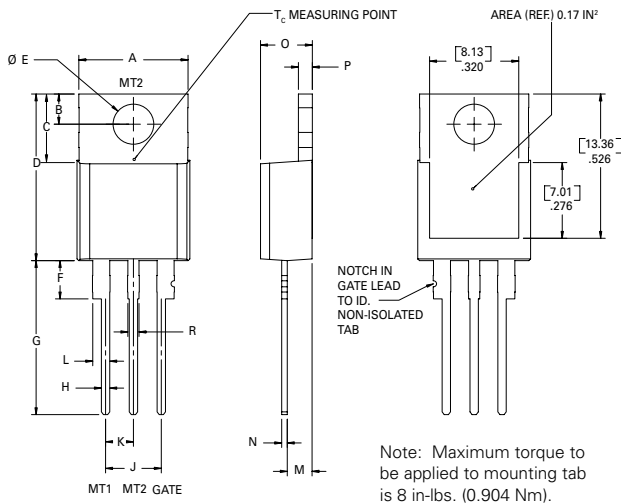

Dimension	Inches		Millimeters	
	Min	Max	Min	Max
A	0.380	0.420	9.65	10.67
B	0.105	0.115	2.67	2.92
C	0.230	0.250	5.84	6.35
D	0.590	0.620	14.99	15.75
E	0.142	0.147	3.61	3.73
F	0.110	0.130	2.79	3.30
G	0.540	0.575	13.72	14.61
H	0.025	0.035	0.64	0.89
J	0.195	0.205	4.95	5.21
K	0.095	0.105	2.41	2.67
L	0.060	0.075	1.52	1.91
M	0.085	0.095	2.16	2.41
N	0.018	0.024	0.46	0.61
O	0.178	0.188	4.52	4.78
P	0.045	0.060	1.14	1.52
R	0.038	0.048	0.97	1.22

Dimensions — TO-220AB (L Package) — Isolated Mounting Tab

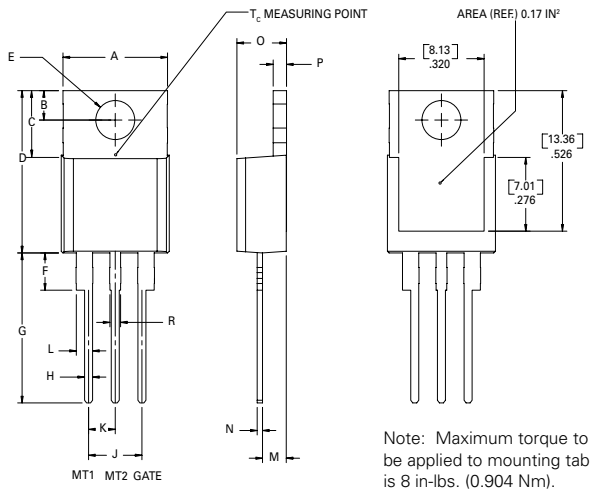

Dimension	Inches		Millimeters	
	Min	Max	Min	Max
A	0.380	0.420	9.65	10.67
B	0.105	0.115	2.66	2.92
C	0.230	0.250	5.85	6.35
D	0.590	0.620	14.98	15.75
E	0.142	0.147	3.61	3.73
F	0.110	0.130	2.80	3.30
G	0.540	0.575	13.71	14.60
H	0.025	0.035	0.63	0.89
J	0.195	0.205	4.95	5.21
K	0.095	0.105	2.41	2.67
L	0.060	0.075	1.52	1.91
M	0.085	0.095	1.78	2.16
N	0.018	0.024	0.45	0.61
O	0.178	0.188	4.52	4.78
P	0.045	0.060	1.14	1.53
R	0.038	0.048	0.97	1.22

Dimensions — TO-263 (N Package) — D²Pak Surface Mount

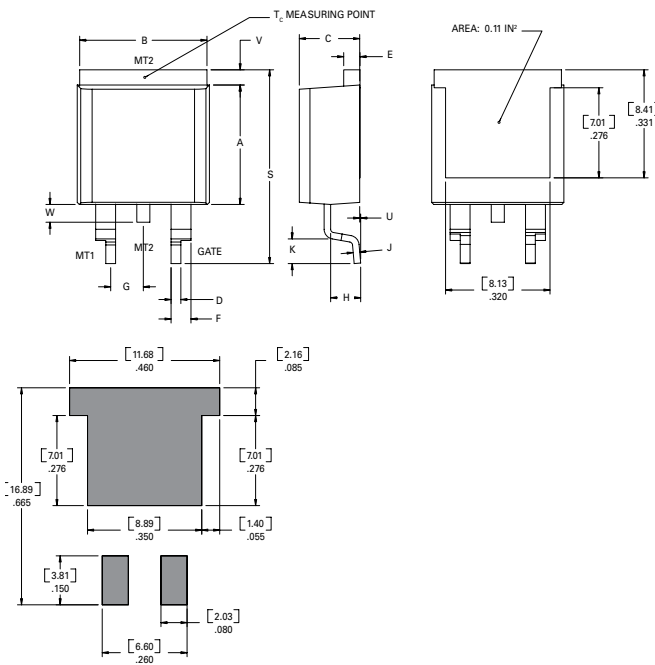

Dimension	Inches		Millimeters	
	Min	Max	Min	Max
A	0.360	0.370	9.14	9.40
B	0.380	0.420	9.65	10.67
C	0.178	0.188	4.52	4.78
D	0.025	0.035	0.64	0.89
E	0.045	0.060	1.14	1.52
F	0.060	0.075	1.52	1.91
G	0.095	0.105	2.41	2.67
H	0.092	0.102	2.34	2.59
J	0.018	0.024	0.46	0.61
K	0.090	0.110	2.29	2.79
S	0.590	0.625	14.99	15.88
V	0.035	0.045	0.89	1.14
U	0.002	0.010	0.05	0.25
W	0.040	0.070	1.02	1.78

Dimensions – TO-218AC (K Package) – Isolated Mounting Tab

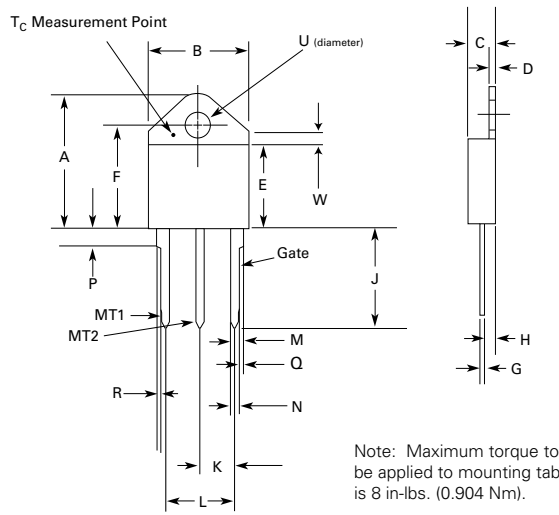

Dimension	Inches		Millimeters	
	Min	Max	Min	Max
A	0.810	0.835	20.57	21.21
B	0.610	0.630	15.49	16.00
C	0.178	0.188	4.52	4.78
D	0.055	0.070	1.40	1.78
E	0.487	0.497	12.37	12.62
F	0.635	0.655	16.13	16.64
G	0.022	0.029	0.56	0.74
H	0.075	0.095	1.91	2.41
J	0.575	0.625	14.61	15.88
K	0.211	0.219	5.36	5.56
L	0.422	0.437	10.72	11.10
M	0.058	0.068	1.47	1.73
N	0.045	0.055	1.14	1.40
P	0.095	0.115	2.41	2.92
Q	0.008	0.016	0.20	0.41
R	0.008	0.016	0.20	0.41
U	0.164	0.165	4.10	4.20
W	0.085	0.095	2.17	2.42

Dimensions – TO-218X (J Package) – Isolated Mounting Tab

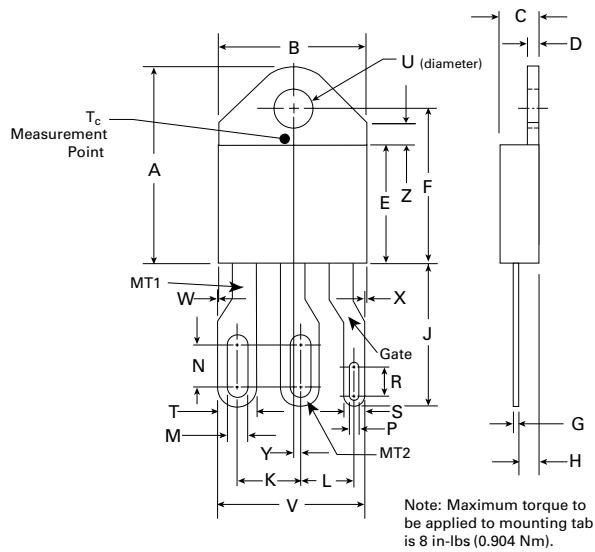

Dimension	Inches		Millimeters	
	Min	Max	Min	Max
A	0.810	0.835	20.57	21.21
B	0.610	0.630	15.49	16.00
C	0.178	0.188	4.52	4.78
D	0.055	0.070	1.40	1.78
E	0.487	0.497	12.37	12.62
F	0.635	0.655	16.13	16.64
G	0.022	0.029	0.56	0.74
H	0.075	0.095	1.91	2.41
J	0.575	0.625	14.61	15.88
K	0.256	0.264	6.50	6.71
L	0.220	0.228	5.58	5.79
M	0.080	0.088	2.03	2.24
N	0.169	0.177	4.29	4.49
P	0.034	0.042	0.86	1.07
R	0.113	0.121	2.87	3.07
S	0.086	0.096	2.18	2.44
T	0.156	0.166	3.96	4.22
U	0.164	0.165	0.410	0.420
V	0.603	0.618	15.31	15.70
W	0.000	0.005	0.00	0.13
X	0.003	0.012	0.07	0.30
Y	0.028	0.032	0.71	0.81
Z	0.085	0.095	2.17	2.42

Product Selector

Part Number	Voltage			Gate Sensitivity Quadrants	Package
	400V	600V	800V		
QJxx25RH4	-	-	X	35 mA	TO-220R
QJxx25LH4	-	-	X	35 mA	TO-220L
QJxx25NH4	-	-	X	35 mA	TO-263 D ² -Pak
QJxx25RH5	X	X	-	50 mA	TO-220R
QJxx25LH5	X	X	-	50 mA	TO-220L
QJxx25NH5	X	X	-	50 mA	TO-263 D ² -Pak
QJxx25NH6	X	X	-	80 mA	TO-263 D ² -Pak
QJxx25JH6	X	X	-	80 mA	TO-218X
QJxx25KH6	X	X	-	80 mA	TO-218AC
QJxx25LH6	X	X	-	80 mA	TO-220L
QJxx25RH6	X	X	-	80 mA	TO-220R

Packing Options

Part Number	Marking	Weight	Packing Mode	Base Quantity
QJxx25RH4TP	QJxx25RH4	2.20g	Tube Pack	500 (50 per tube)
QJxx25LH4TP	QJxx25LH4	2.20g	Tube Pack	500 (50 per tube)
QJxx25NH4TP	QJxx25NH4	1.60g	Tube Pack	500 (50 per tube)
QJxx25NH4RP	QJxx25NH4	1.60g	Embossed Carrier	500
QJxx25RH5TP	QJxx25RH5	2.20g	Tube Pack	500 (50 per tube)
QJxx25LH5TP	QJxx25LH5	2.20g	Tube Pack	500 (50 per tube)
QJxx25NH5TP	QJxx25NH5	1.60g	Tube Pack	500 (50 per tube)
QJxx25NH5RP	QJxx25NH5	1.60g	Embossed Carrier	500
QJxx25NH6TP	QJxx25NH6	1.60g	Tube Pack	500 (50 per tube)
QJxx25NH6RP	QJxx25NH6	1.60g	Embossed Carrier	500
QJxx25JH6TP	QJxx25JH6	5.23g	Tube Pack	250 (25 per tube)
QJxx25KH6TP	QJxx25KH6	4.40g	Tube Pack	250 (25 per tube)
QJxx25LH6TP	QJxx25LH6	2.20g	Tube Pack	500 (50 per tube)
QJxx25RH6TP	QJxx25RH6	2.20g	Tube Pack	500 (50 per tube)

Part Numbering System

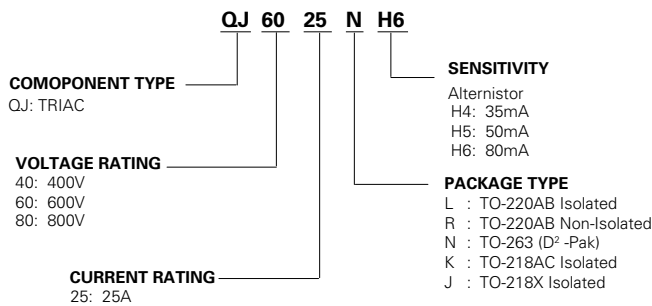

Part Marking System

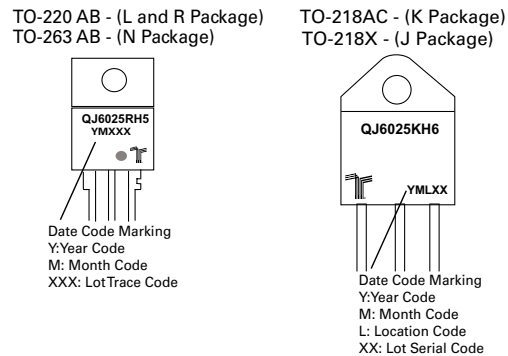

TO-263 Embossed Carrier Reel Pack (RP) Specifications

Meets all EIA-481-2 Standards

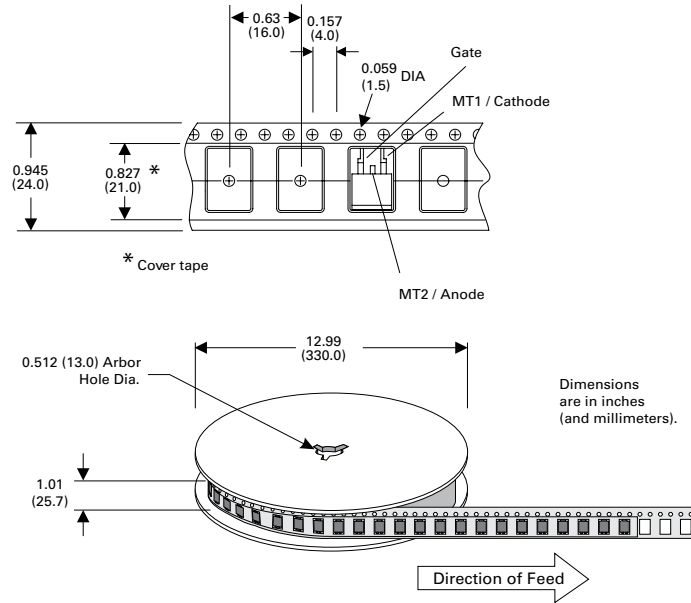

Disclaimer Notice - Information furnished is believed to be accurate and reliable. However, users should independently evaluate the suitability of and test each product selected for their own applications. Littelfuse products are not designed for, and may not be used in, all applications. Read complete Disclaimer Notice at www.littelfuse.com/disclaimer-electronics.

©2017 Littelfuse, Inc

Specifications are subject to change without notice.

Revised: 06/03/19

X-ON Electronics

Largest Supplier of Electrical and Electronic Components

Click to view similar products for [Triacs](#) category:

Click to view products by [Littelfuse](#) manufacturer:

Other Similar products are found below :

[T2035H-6G](#) [BT137-600-0Q](#) [Z0409MF0AA2](#) [Z0109NA 2AL2](#) [ACST1635T-8FP](#) [BCR20RM-30LA#B00](#) [CMA60MT1600NHR](#) [NTE5611](#)
[NTE5612](#) [NTE5613](#) [NTE5621](#) [NTE5623](#) [NTE5629](#) [NTE5638-08](#) [NTE5688](#) [NTE5689](#) [NTE5690](#) [T1235T-8I](#) [BTA312-600CT.127](#) [T1210T-](#)
[8G-TR](#) [Z0109NN0,135](#) [T2535T-8I](#) [T2535T-8T](#) [TN4050-12WL](#) [MAC4DLM-1G](#) [BT137-600E,127](#) [BT137X-600D](#) [BT148W-600R,115](#)
[BT258-500R,127](#) [BTA08-800BW3G](#) [BTA140-800,127](#) [BTA30-600CW3G](#) [BTA30-600CW3G](#) [BTB08-800BW3G](#) [BTB16-600CW3G](#)
[BTB16-600CW3G](#) [Z0410MF0AA2](#) [Z0109MN,135](#) [T825T-6I](#) [T1635T-6I](#) [T1220T-6I](#) [NTE5638](#) [TYN612MRG](#) [TYN1225RG](#) [TPDV840RG](#)
[ACST1235-8FP](#) [ACS302-6T3-TR](#) [BT134-600D,127](#) [BT134-600G,127](#) [BT136X-600E,127](#)