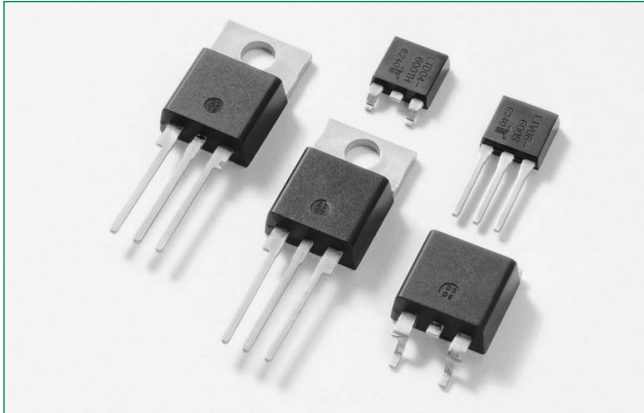

LJxx08xx & QJxx08xHx & QJxx08xx Series

8 Amp High Temp Sensitive, Standard & Alternistor(High Communication)Triacs

HF **RoHS**

Description

This 8 A High Temperature Alternistor Triac solid state switch series is designed for AC switching and phase control applications such as motor speed and temperature modulation controls, lighting controls, and static switching relays.

Sensitive type components guarantee gate control in Quadrants I & IV as needed for digital control circuitry.

Alternistor type components only operate in quadrants I, II, & III and are used in circuits requiring high dv/dt capability.

Standard type devices normally operate in Quadrants I & III triggered from AC line

Additional Information



Resources



Accessories



Samples

Agency Approvals and Environmental

Environmental Approvals



Note: UL recognition agency file number E71639 (L package only)

Main Features

Symbol	Value	Unit
$I_{T(RMS)}$	8	A
V_{DRM}/V_{RRM}	400 or 600 or 800	V
$I_{GT(Q1)}$	10 to 50	mA

Schematic Symbol

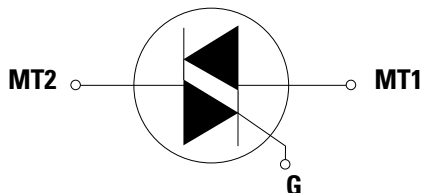

Features & Benefits

- 150°C maximum junction temperature
- Voltage capability up to 800V
- Surge capability up to 100A at 60Hz half cycle
- Solid-state switching eliminates arcing or contact bounce that create voltage transients
- No contacts to wear out from reaction of switching events
- Restricted (or limited) RFI generation, depending on activation point of sine wave
- Requires only a short gate activation pulse in each half-cycle
- Halogen free and RoHS compliant

Applications

Excellent for AC switching and phase control applications such as heating, lighting, and motor speed controls.

Typical applications are AC solid-state switches, light dimmers, power tools, home/brown goods and white goods appliances.

Alternistor Triacs (no snubber required) are used in applications with high inductive loads requiring the highest commutation performance.

LJxx08xx & QJxx08xHx & QJxx08xx Series

8 Amp High Temp Sensitive, Standard & Alternistor(High Communication)Triacs

Absolute Maximum Ratings – Sensitive Triac (4 Quadrants)

Symbol	Parameter	Value	Unit
V_{DSM}/V_{RSM}	Peak non-repetitive blocking voltage	$P_W=100 \mu s$, 600V Version	700 V
$I_{T(RMS)}$	RMS on-state current (full sine wave)	LJxx08Vy/LJxx08Dy $T_C = 130^\circ C$	8 A
I_{TSM}	Non repetitive surge peak on-state current (full cycle, T_J initial = $25^\circ C$)	f = 50 Hz $t = 20$ ms	70 A
		f = 60 Hz $t = 16.7$ ms	84 A
I^2t	I^2t Value for fusing	$t_p = 8.3$ ms	29 A^2s
di/dt	Critical rate of rise of on-state current $I_G = 50mA$ with 0.1 μs rise time	f = 60 Hz $T_J = 150^\circ C$	150 A/ μs
I_{GTM}	Peak gate trigger current	$t_p=20\mu s$ $T_J = 150^\circ C$	4 A
$P_{G(AV)}$	Average gate power dissipation	$T_J = 150^\circ C$	0.3 W
T_{stg}	Storage temperature range		-40 to 150 $^\circ C$
T_J	Operating junction temperature range		-40 to 150 $^\circ C$

Note: xx=voltage/10, γ = sensitivity

Absolute Maximum Ratings – Alternistor (3 Quadrants)

Symbol	Parameter	Value	Unit	
V_{DSM}/V_{RSM}	Peak non-repetitive blocking vlotage	$P_W=100\mu s$ 600V	700 V	
		800V	1000 V	
$I_{T(RMS)}$	RMS on-state current (full sine wave)	QJxx08VHy/QJxx08DHy $T_C = 130^\circ C$	8 A	
		QJxx08LHy $T_C = 125^\circ C$		
		QJxx08RHx/QJxx08NHx $T_C = 140^\circ C$		
I_{TSM}	Non repetitive surge peak on-state current (full cycle, T_J initial= $25^\circ C$)	f=50HZ $t=20ms$ QJxx08VHy/QJxx08DHy	70 A	
		QJxx08LHy/QJxx08RHx/QJxx08NHx	83 A	
		QJxx08VHy/QJxx08DHy	84 A	
		QJxx08LHy/QJxx08RHx/QJxx08NHx	100 A	
I^2t	I^2t Value for fusing	$tp=8.3ms$	QJxx08VHy/QJxx08DHy	29 A^2s
			QJxx08LHy/QJxx08RHx/QJxx08NHx	26.5 A^2s
di/dt	Critical rate of rise of on-state current	f=60HZ $T_J=150^\circ C$	70 A/us	
I_{GTM}	Peak gate trigger current	$tp=20\mu s$ $T_J=150^\circ C$	4 A/us	
$P_{G(AV)}$	Average gate power dissipation	$T_J=150^\circ C$	0.5 W	
T_{STG}	Storage temperature range		-40 to 150 $^\circ C$	
T_J	Operating junction temperature range		-40 to 150 $^\circ C$	

Note: xx=voltage/10, γ = sensitivity

Absolute Maximum Ratings - Standard Triac (4 Quadrants)

Symbol	Parameter	Value	Unit
V_{DSM}/V_{RSM}	Peak non-repetitive blocking vlotage	$P_W=100\mu s$ 800V	1000 V
$I_{T(RMS)}$	RMS on-state current (full sine wave)	QJxx08L5 $T_C = 125^\circ C$	8 A
		QJxx08R5/QJxx08N5 $T_C = 140^\circ C$	
I_{TSM}	Non repetitive surge peak on-state current (full cycle, T_J initial= $25^\circ C$)	f=50HZ $t=20ms$	100 A
		f=60HZ $t=16.7ms$	120 A
I^2t	I^2t Value for fusing	$tp=8.3ms$ QJxx08x5	26.5 A^2s
di/dt	Critical rate of rise of on-state current	f=60HZ $T_J=150^\circ C$	70 A/us
I_{GTM}	Peak gate trigger current	$tp=20\mu s$ $T_J=150^\circ C$	4 A/us
$P_{G(AV)}$	Average gate power dissipation	$T_J=150^\circ C$	0.5 W
T_{STG}	Storage temperature range		-40 to 150 $^\circ C$
T_J	Operating junction temperature range		-40 to 150 $^\circ C$

Note: xx=voltage/10, x = package

LJxx08xx & QJxx08xHx & QJxx08xx Series

8 Amp High Temp Sensitive, Standard & Alternistor(High Communication)Triacs

Electrical Characteristics ($T_J = 25^\circ\text{C}$, unless otherwise specified) – Sensitive Triac (4 Quadrants)

Symbol	Test Conditions	Quadrant	LJxx08x8	Unit
I_{GT}	$V_D = 12\text{V}$ $R_L = 60\ \Omega$	I – II – III IV	10 20	mA
V_{GT}		ALL	1.3	V
V_{GD}	$V_D = V_{DRM}$ $R_L = 3.3\ \text{k}\Omega$ $T_J = 150^\circ\text{C}$	ALL	0.15	V
I_H	$I_T = 100\text{mA}$	MAX.	25	mA
dv/dt	$V_D = V_{DRM}$ Gate Open $T_J = 150^\circ\text{C}$	400V	80	V/ μs
		600V	50	
(dv/dt)c	(di/dt)c = 4.3 A/ms $T_J = 150^\circ\text{C}$	TYP.	2	V/ μs
t_{gt}	$I_G = 100\text{mA}$ $P_W = 15\mu\text{s}$ $I_T = 11.3\ \text{A(pk)}$	TYP.	12	μs

Note: xx=voltage/10, x = package,

Electrical Characteristics ($T_J = 25^\circ\text{C}$, unless otherwise specified) – Alternistor Triac (3 Quadrants)

Symbol	Test Conditions	Quadrant	QJxx08xH2	QJxx08xH3	QJxx08xH4	Unit		
I_{GT}	$V_D = 12\text{V}$ $R_L = 60\ \Omega$	I – II – III	10	20	35	mA		
V_{GT}		I – II – III	1.3			V		
V_{GD}	$V_D = V_{DRM}$ $R_L = 3.3\ \text{k}\Omega$ $T_J = 150^\circ\text{C}$	I – II – III		0.15		V		
I_H	$I_T = 100\text{mA}$	MAX.	25	30	35	mA		
dv/dt	$V_D = V_{DRM}$ Gate Open $T_J = 150^\circ\text{C}$	QJxx08xHy	MIN.	400V	150	250	350	V/ μs
				600V	100	200	250	
				800V	-	-	450	
(dv/dt)c	(di/dt)c = 4.3 A/ms $T_J = 150^\circ\text{C}$	MIN.	15	18	20	V/ μs		
t_{gt}	$I_G = 100\text{mA}$ $P_W = 15\mu\text{s}$ $I_T = 11.3\ \text{A(pk)}$	TYP.	10	10	10	μs		

Note: xx=voltage/10, x = package

Electrical Characteristics ($T_J = 25^\circ\text{C}$, unless otherwise specified) – Standard Triac

Symbol	Test Conditions	Quadrant	Valye	Unit
			QJxx08x5	
I_{GT}	$V_D = 12\text{V}$ $R_L = 60\ \Omega$	I – II – III	50	mA
		IV	50	
V_{GT}	$V_D = V_{DRM}$ $R_L = 3.3\ \text{k}\Omega$ $T_J = 150^\circ\text{C}$	ALL	1.3	V
V_{GD}		ALL	0.2	V
I_H	Initial $I_T = 100\text{mA}$	MAX.	50	mA
dv/dt	$V_D = V_{DRM}$ Gate Open $T_J = 150^\circ\text{C}$	QJxx08xHy	1000	V/ μs
(dv/dt)c	(di/dt)c = 3.2 A/ms $T_J = 150^\circ\text{C}$	MIN.	4	V/ μs
t_{gt}	$I_G = 2X$ $I_{GT} P_W = 15\mu\text{s}$ $I_T = 8.5\ \text{A}_{(pk)}$	TYP.	11	μs

LJxx08xx & QJxx08xHx & QJxx08xx Series

8 Amp High Temp Sensitive, Standard & Alternistor(High Communication)Triacs

Static Characteristics

Symbol	Test Conditions			Value	Unit		
V_{TM}	$I_{TM} = 8.4A, t_p = 380 \mu s$			MAX	1.5	V	
I_{DRM}/I_{RRM}	$V_{DRM}=V_{RRM}$	LJxx08xy	$T_J = 25^\circ C$	400-600V	MAX	10	μA
			$T_J = 125^\circ C$	400-600V		0.5	mA
			$T_J = 150^\circ C$	400-600V		3	
		QJxx08xHy	$T_J = 25^\circ C$	400-800V		10	μA
			$T_J = 125^\circ C$	400-800V		0.5	mA
			$T_J = 150^\circ C$	400-800V		3	
		QJxx08x5	$T_J = 25^\circ C$	800V		10	μA
			$T_J = 125^\circ C$			0.5	mA
			$T_J = 150^\circ C$			4	

Note: xx=voltage/10, x=package, y = sensitivity

Thermal Resistances

Symbol	Parameter		Value	Unit
R_{thJC}	Junction to case (AC)	LJ/QJxx08Vyy	1.5	$^\circ C/W$
		LJ/QJxx08Dyy		
		QJxx08R5/QJxx08N5	1.2	
		QJxx08L5	2.3	
R_{thJA}	Junction to ambient	LJ/QJxx08Vyy	70	$^\circ C/W$
		LJ/QJxx08Dyy		
		QJxx08R5	45	
		QJxx08L5	90	

Figure 1:
Definition of Quadrants

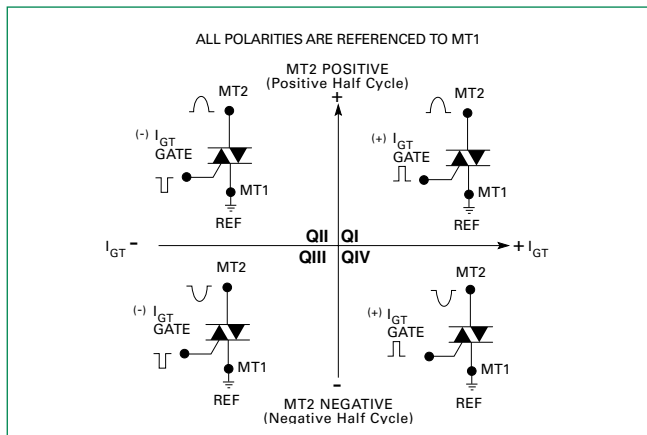

Note: Alternistors will not operate in QIV

Figure 2:
Normalized DC Gate Trigger Current for All Quadrants vs. Junction Temperature

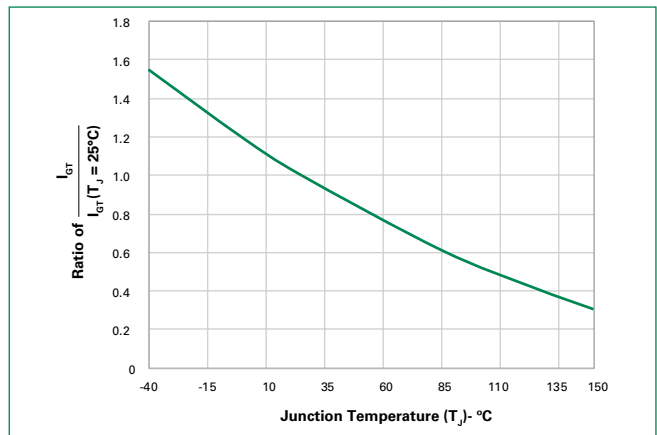

LJxx08xx & QJxx08xHx & QJxx08xx Series

8 Amp High Temp Sensitive, Standard & Alternistor(High Communication)Triacs

Figure 3:

Normalized DC Holding Current vs. Junction Temperature

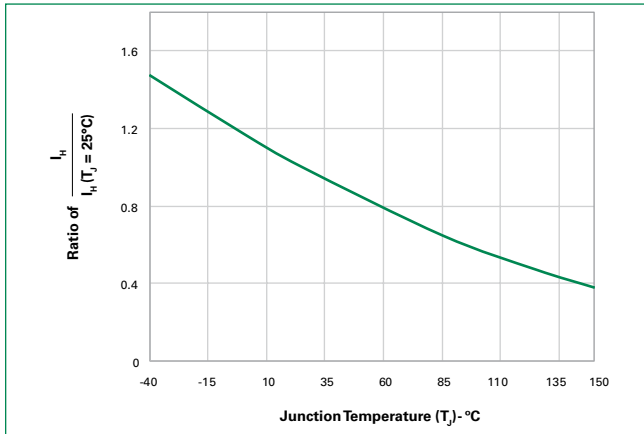

Figure 4:

Normalized DC Gate Trigger Voltage for All Quadrants vs. Junction Temperature

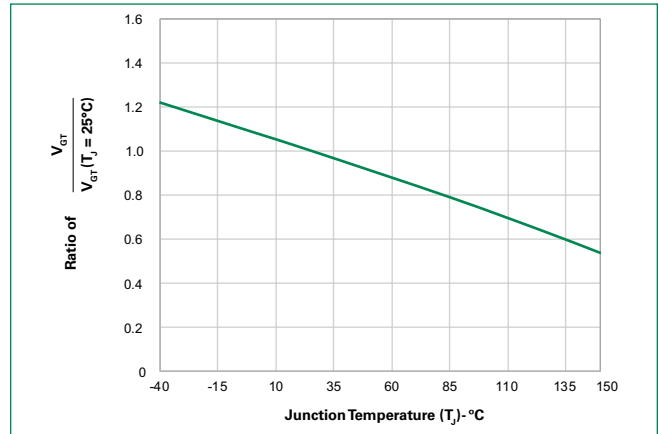

Figure 5:

Power Dissipation (Typical) vs. RMS On-State Current

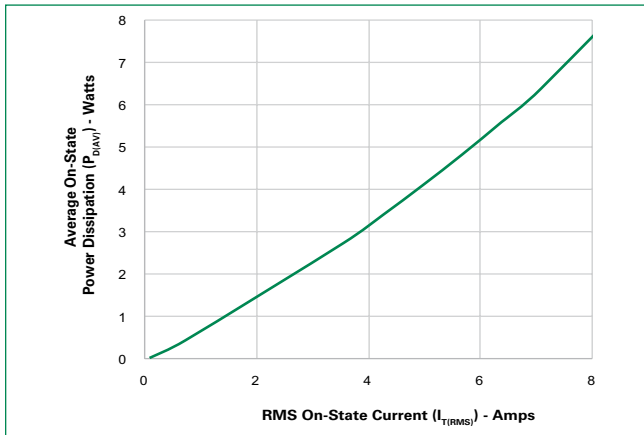

Figure 6:

Maximum Allowable Case Temperature vs. On-State Current

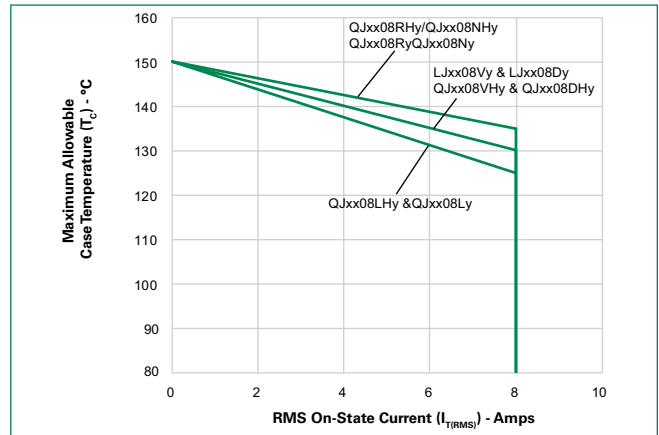
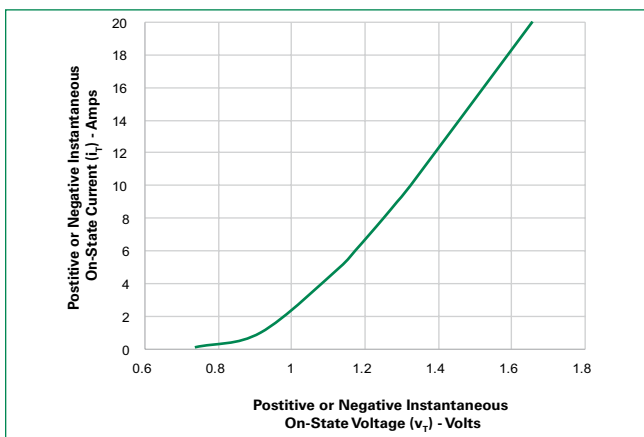

Figure 7:

On-State Current vs. On-State Voltage (Typical)



LJxx08xx & QJxx08xHx & QJxx08xx Series

8 Amp High Temp Sensitive, Standard & Alternistor(High Communication)Triacs

Figure 8: Surge Peak On-State Current vs. Number of Cycles

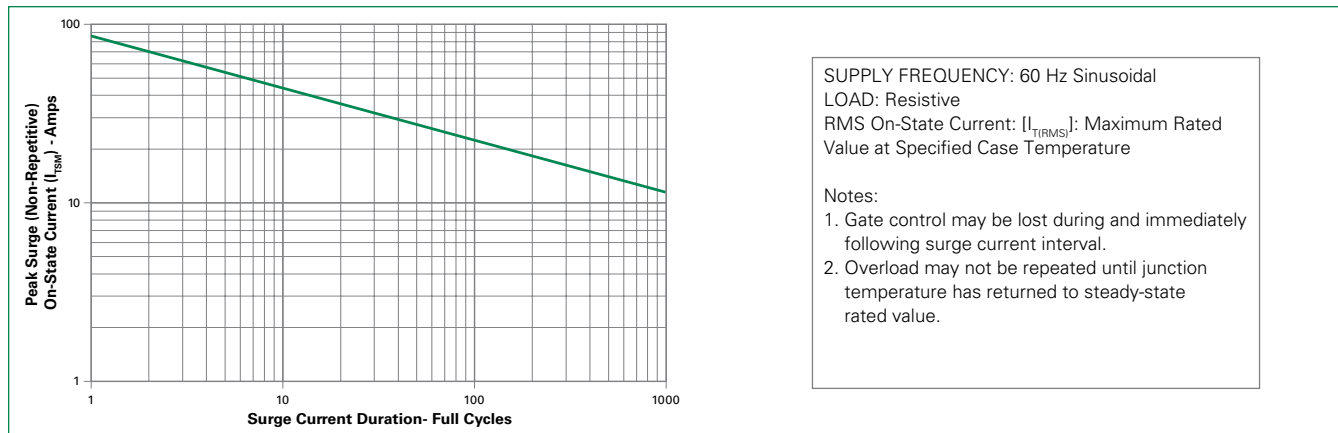

Soldering Parameters

Reflow Condition		Pb – Free assembly
Pre Heat	- Temperature Min ($T_{s(min)}$)	150°C
	- Temperature Max ($T_{s(max)}$)	200°C
	- Time (min to max) (t_p)	60 – 180 secs
Average ramp up rate (Liquidus Temp) (T_L) to peak		5°C/second max
$T_{s(max)}$ to T_L - Ramp-up Rate		5°C/second max
Reflow	- Temperature (T_L) (Liquidus)	217°C
	- Time (t_L)	60 – 150 seconds
Peak Temperature (T_p)		260 ^{+0/-5} °C
Time within 5°C of actual peak Temperature (t_p)		20 – 40 seconds
Ramp-down Rate		5°C/second max
Time 25°C to peak Temperature (T_p)		8 minutes Max.
Do not exceed		280°C

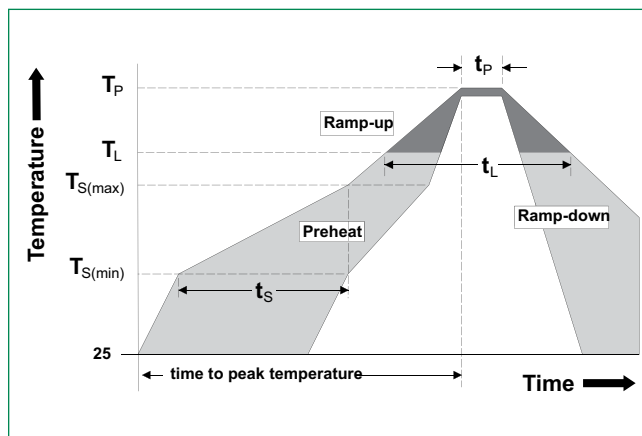

Physical Specifications

Terminal Finish	100% Matte Tin-plated
Body Material	UL Recognized compound meeting flammability rating V-0.
Terminal Material	Copper Alloy

Design Considerations

Careful selection of the correct component for the application's operating parameters and environment will go a long way toward extending the operating life of the Thyristor. Good design practice should limit the maximum continuous current through the main terminals to 75% of the component rating. Other ways to ensure long life for a power discrete semiconductor are proper heat sinking and selection of voltage ratings for worst case conditions. Overheating, overvoltage (including dv/dt), and surge currents are the main killers of semiconductors. Correct mounting, soldering, and forming of the leads also help protect against component damage.

Environmental Specifications

Test	Specifications and Conditions
AC Blocking (V_{DRM})	MIL-STD-750, M-1040, Cond A Applied Peak AC voltage @ 150°C for 1008 hours
Temperature Cycling	MIL-STD-750, M-1051, 1000 cycles; -55°C to +150°C; 15-min dwell-time
Temperature/Humidity	EIA / JEDEC, JESD22-A101 1008 hours; 320V - DC: 85°C; 85% rel humidity
High Temp Storage	MIL-STD-750, M-1031, 1008 hours; 150°C
Low-Temp Storage	1008 hours; -40°C
Resistance to Solder Heat	MIL-STD-750 Method 2031
Solderability	ANSI/J-STD-002, category 3, Test A
Lead Bend	MIL-STD-750, M-2036 Cond E

LJxx08xx & QJxx08xHx & QJxx08xx Series

8 Amp High Temp Sensitive, Standard & Alternistor(High Communication)Triacs

Dimensions – TO-251AA (V-Package) – V-PAK Through Hole

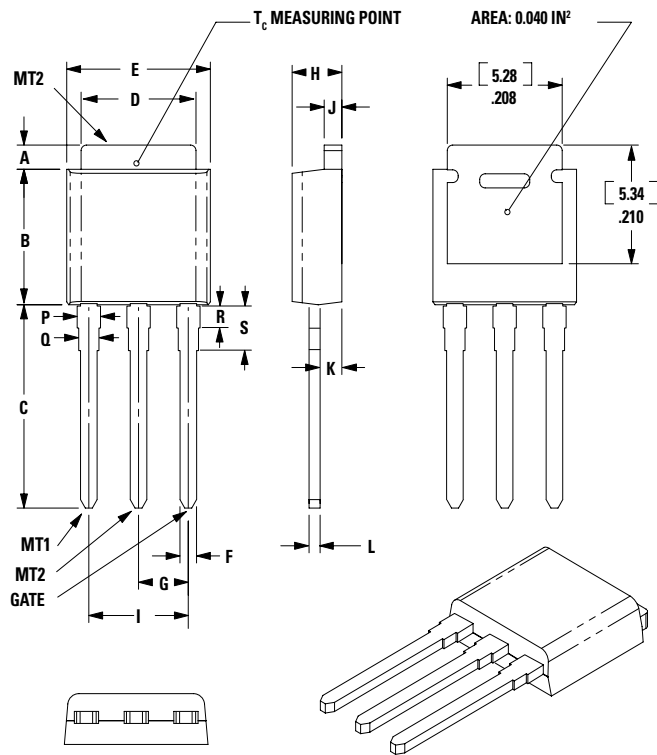

Dimension	Inches			Millimeters		
	Min	Typ	Max	Min	Typ	Max
A	0.037	0.040	0.043	0.94	1.01	1.09
B	0.235	0.242	0.245	5.97	6.15	6.22
C	0.350	0.361	0.375	8.89	9.18	9.53
D	0.205	0.208	0.213	5.21	5.29	5.41
E	0.255	0.262	0.265	6.48	6.66	6.73
F	0.027	0.031	0.033	0.69	0.80	0.84
G	0.087	0.090	0.093	2.21	2.28	2.36
H	0.085	0.092	0.095	2.16	2.34	2.41
I	0.176	0.180	0.184	4.47	4.57	4.67
J	0.018	0.020	0.023	0.46	0.51	0.58
K	0.035	0.037	0.039	0.90	0.95	1.00
L	0.018	0.020	0.023	0.46	0.52	0.58
P	0.042	0.047	0.052	1.06	1.20	1.32
Q	0.034	0.039	0.044	0.86	1.00	1.11
R	0.034	0.039	0.044	0.86	1.00	1.11
S	0.074	0.079	0.084	1.86	2.00	2.11

Dimensions – TO-252AA (D-Package) – D-PAK Surface Mount

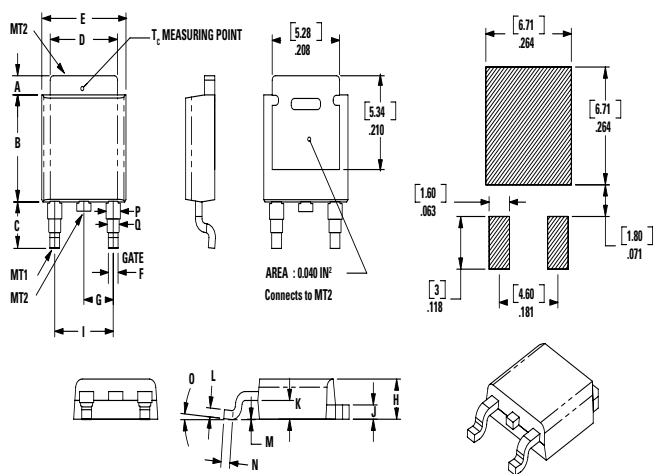

Dimension	Inches			Millimeters		
	Min	Typ	Max	Min	Typ	Max
A	0.037	0.040	0.043	0.94	1.01	1.09
B	0.235	0.243	0.245	5.97	6.16	6.22
C	0.106	0.108	0.113	2.69	2.74	2.87
D	0.205	0.208	0.213	5.21	5.29	5.41
E	0.255	0.262	0.265	6.48	6.65	6.73
F	0.027	0.031	0.033	0.69	0.80	0.84
G	0.087	0.090	0.093	2.21	2.28	2.36
H	0.085	0.092	0.095	2.16	2.33	2.41
I	0.176	0.179	0.184	4.47	4.55	4.67
J	0.018	0.020	0.023	0.46	0.51	0.58
K	0.035	0.037	0.039	0.90	0.95	1.00
L	0.018	0.020	0.023	0.46	0.51	0.58
M	0.000	0.000	0.004	0.00	0.00	0.10
N	0.021	0.026	0.027	0.53	0.67	0.69
O	0°	0°	5°	0°	0°	5°
P	0.042	0.047	0.052	1.06	1.20	1.32
Q	0.034	0.039	0.044	0.86	1.00	1.11

LJxx08xx & QJxx08xHx & QJxx08xx Series

8 Amp High Temp Sensitive, Standard & Alternistor(High Communication)Triacs

Dimensions – TO-220AB (R-Package) – Non-Isolated Mounting Tab Common with Center Lead

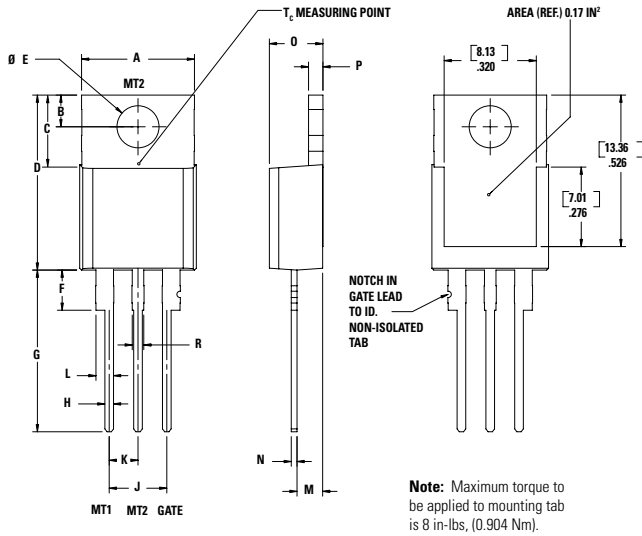

Dimension	Inches		Millimeters	
	Min	Max	Min	Max
A	0.380	0.420	9.65	10.67
B	0.105	0.115	2.67	2.92
C	0.230	0.250	5.84	6.35
D	0.590	0.620	14.99	15.75
E	0.142	0.147	3.61	3.73
F	0.110	0.130	2.79	3.30
G	0.540	0.575	13.72	14.61
H	0.025	0.035	0.64	0.89
J	0.195	0.205	4.95	5.21
K	0.095	0.105	2.41	2.67
L	0.060	0.075	1.52	1.91
M	0.085	0.095	2.16	2.41
N	0.018	0.024	0.46	0.61
O	0.178	0.188	4.52	4.78
P	0.045	0.060	1.14	1.52
R	0.038	0.048	0.97	1.22

Dimensions – TO-220AB (L-Package) – Isolated Mounting Tab

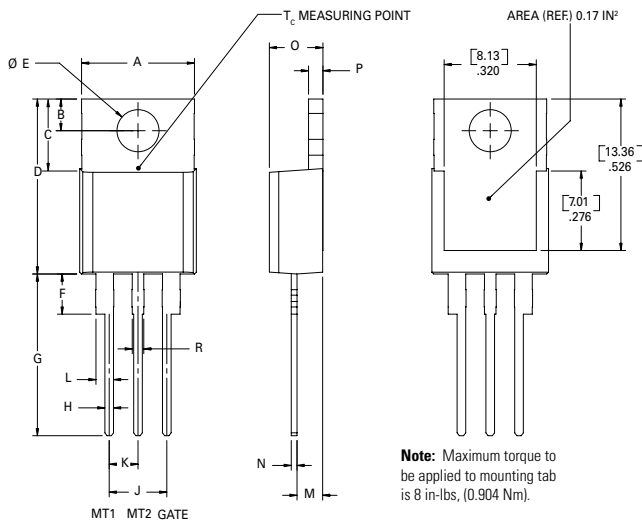

Dimension	Inches		Millimeters	
	Min	Max	Min	Max
A	0.380	0.420	9.65	10.67
B	0.105	0.115	2.67	2.92
C	0.230	0.250	5.84	6.35
D	0.590	0.620	14.99	15.75
E	0.142	0.147	3.61	3.73
F	0.110	0.130	2.79	3.30
G	0.540	0.575	13.72	14.61
H	0.025	0.035	0.64	0.89
J	0.195	0.205	4.95	5.21
K	0.095	0.105	2.41	2.67
L	0.060	0.075	1.52	1.91
M	0.085	0.095	2.16	2.41
N	0.018	0.024	0.46	0.61
O	0.178	0.188	4.52	4.78
P	0.045	0.060	1.14	1.52
R	0.038	0.048	0.97	1.22

LJxx08xx & QJxx08xHx & QJxx08xx Series

8 Amp High Temp Sensitive, Standard & Alternistor(High Communication)Triacs

Dimensions – TO-263AB (N-Package) – D2-PAK Surface Mount

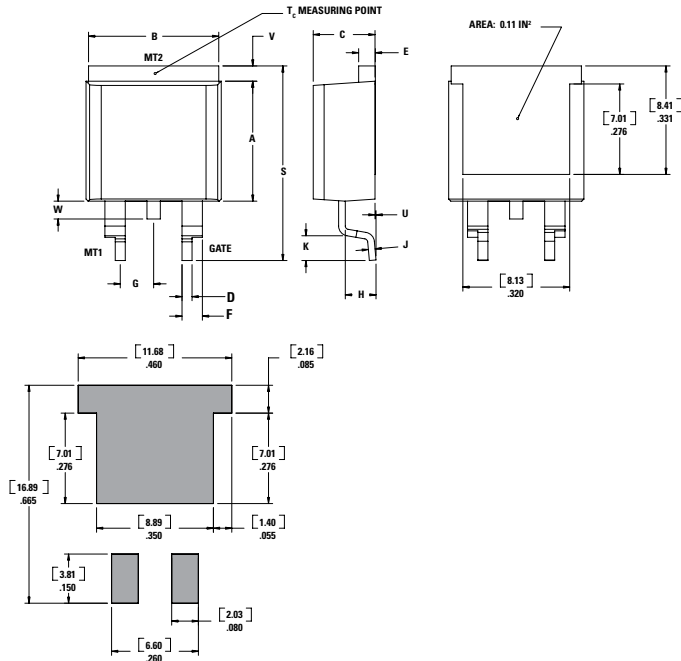

Dimension	Inches		Millimeters	
	Min	Max	Min	Max
A	0.360	0.370	9.14	9.40
B	0.380	0.420	9.65	10.67
C	0.178	0.188	4.52	4.78
D	0.025	0.035	0.64	0.89
E	0.045	0.060	1.14	1.52
F	0.060	0.075	1.52	1.91
G	0.095	0.105	2.41	2.67
H	0.092	0.102	2.34	2.59
J	0.018	0.024	0.46	0.61
K	0.090	0.110	2.29	2.79
S	0.590	0.625	14.99	15.88
V	0.035	0.045	0.89	1.14
U	0.002	0.010	0.05	0.25
W	0.040	0.070	1.02	1.78

Product Selector

Part Number	Voltage			Gate Sensitivity Quadrants		Type	Package
	400V	600V	800V	I – II – III	IV		
LJxx08D8	x	x	-	10mA	20mA	Sensitive Triac	TO-252 D-PAK
LJxx08V8	x	x	-	10mA	20mA	Sensitive Triac	TO-251 V-PAK
QJxx08DH2	x	x	-	10mA	-	Alternistor Triac	TO-252 D-PAK
QJxx08VH2	x	x	-	10mA	-	Alternistor Triac	TO-251 V-PAK
QJxx08DH3	x	x	-	20mA	-	Alternistor Triac	TO-252 D-PAK
QJxx08VH3	x	x	-	20mA	-	Alternistor Triac	TO-251 V-PAK
QJxx08DH4	x	x	-	35mA	-	Alternistor Triac	TO-252 D-PAK
QJxx08VH4	x	x	-	35mA	-	Alternistor Triac	TO-251 V-PAK
QJxx08LH4	-	-	x	35mA	-	Alternistor Triac	Alternistor Triac
QJxx08RH4	-	-	x	35mA	-	Alternistor Triac	Alternistor Triac
QJxx08NH4	-	-	x	35mA	-	Alternistor Triac	Alternistor Triac
QJxx08L5	-	-	x	50mA	50mA	Standard Triac	Standard Triac
QJxx08R5	-	-	x	50mA	50mA	Standard Triac	Standard Triac
QJxx08N5	-	-	x	50mA	50mA	Standard Triac	Standard Triac

Note: xx=voltage/10

LJxx08xx & QJxx08xHx & QJxx08xx Series

8 Amp High Temp Sensitive, Standard & Alternistor(High Communication)Triacs

Packing Options

Part Number	Marking	Weight	Packing Mode	Base Quantity
LJxx08D8TP	LJxx08D8	0.3g	Tube Pack	750(75 per tube)
LJxx08D8RP	LJxx08D8	0.3g	Embossed Carrier	2500
LJxx08V8TP	LJxx08V8	0.4g	Tube Pack	750(75 per tube)
QJxx06VH2TP	QJxx08VH2	0.3g	Tube Pack	750(75 per tube)
QJxx08DH2TP	QJxx08DH2	0.3g	Tube Pack	750(75 per tube)
QJxx08DH2RP	QJxx08DH2	0.3g	Embossed Carrier	2500
QJxx08DH3TP	QJxx08DH3	0.3g	Tube Pack	750(75 per tube)
QJxx08DH3RP	QJxx08DH3	0.3g	Embossed Carrier	2500
QJxx08VH3TP	QJxx08VH3	0.4g	Tube Pack	750(75 per tube)
QJxx08DH4TP	QJxx08DH4	0.3g	Tube Pack	750(75 per tube)
QJxx08DH4RP	QJxx08DH4	0.3g	Embossed Carrier	2500
QJxx08VH4TP	QJxx08VH4	0.4g	Tube Pack	750(75 per tube)
QJxx08LH4TP	QJxx08LH4	2.2g	Tube Pack	1000(50per tube)
QJxx08RH4TP	QJxx08RH4	2.2g	Tube Pack	1000(50per tube)
QJxx08NH4TP	QJxx08NH4	1.6g	Tube Pack	1000(50per tube)
QJxx08NH4RP	QJxx08NH4	1.6g	Embossed Carrier	500
QJxx08L5TP	QJxx08L5	2.2g	Tube Pack	1000(50per tube)
QJxx08R5TP	QJxx08R5	2.2g	Tube Pack	1000(50per tube)
QJxx08N5TP	QJxx08N5	1.6g	Tube Pack	1000(50per tube)
QJxx08N5RP	QJxx08N5	1.6g	Embossed Carrier	500

Note: xx=voltage/10

Part Numbering System

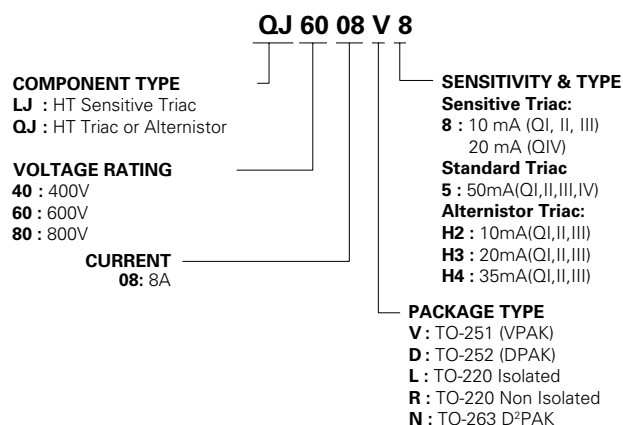

Part Marking System

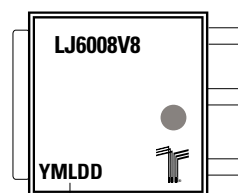

Date Code Marking
Y: Year Code
M: Month Code
L: Location Code
DD: Calendar Code

LJxx08xx & QJxx08xHx & QJxx08xx Series

8 Amp High Temp Sensitive, Standard & Alternistor (High Communication) Triacs

TO-252 Embossed Carrier Reel Pack (RP) Specifications

Meets all EIA-481-2 Standards

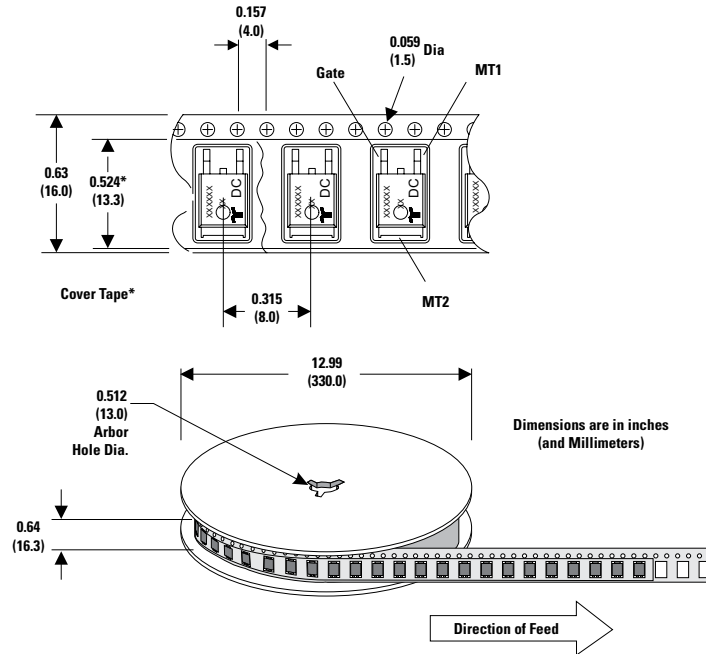

TO-263 Embossed Carrier Reel Pack (RP) Specifications

Meets all EIA-481-2 Standards

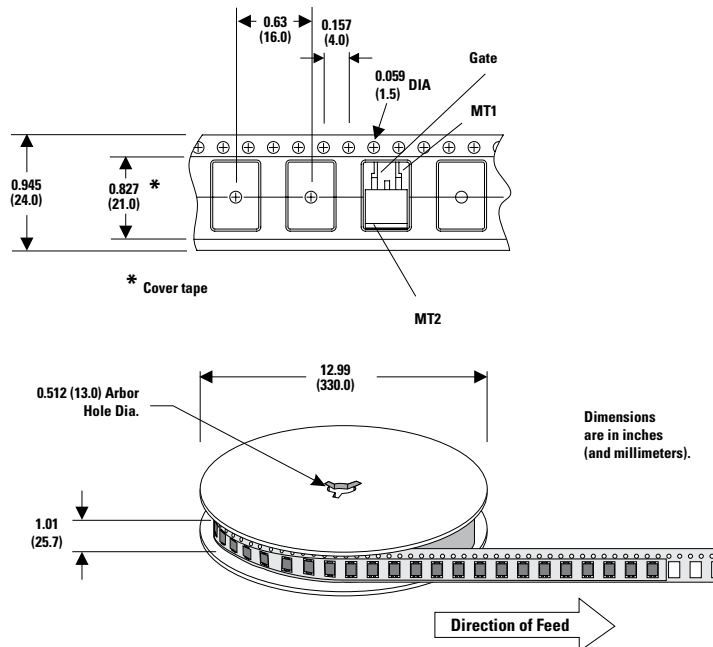

Disclaimer Notice - Information furnished is believed to be accurate and reliable. However, users should independently evaluate the suitability of and test each product selected for their own applications. Littelfuse products are not designed for, and may not be used in, all applications. Read complete Disclaimer Notice at <http://www.littelfuse.com/disclaimer-electronics>.

X-ON Electronics

Largest Supplier of Electrical and Electronic Components

Click to view similar products for [Triacs](#) category:

Click to view products by [Littelfuse](#) manufacturer:

Other Similar products are found below :

[CTA08-1000CW](#) [CTB24-800BW](#) [CTA08-1000C](#) [CTA12-800BWPT](#) [CTA16-1000B](#) [CTB24-800B](#) [BT137-600-0Q](#) [5615](#) [OT415Q](#) [2N6075A](#)
[NTE5629](#) [NTE5688](#) [CTB08-400CW](#) [D31410](#) [BTA425Z-800BTQ](#) [KS100N12](#) [TOPT16-800C0,127](#) [OT408,135](#) [BT134-800E](#) [BT136D](#)
[BTB16Q-600BW](#) [Z0409MF](#) [BTA04-600B](#) [BTA06-600BRG](#) [BTA06-800BWRG](#) [BTA08-600BRG](#) [BTA08-800B](#) [BT136-600,127](#)
[MAC97A6,116](#) [BT137-600E,127](#) [BTB16-600CW3G](#) [BTB16-600CW3G](#) [Z0109MN,135](#) [T825T-6I](#) [T1220T-6I](#) [NTE5638](#) [ACST1235-8FP](#)
[BT136X-600E,127](#) [MAC4DLM-1G](#) [BT134-600D,127](#) [BTA08-600BW3G](#) [NTE56008](#) [NTE56017](#) [NTE56018](#) [NTE56059](#) [NTE5608](#)
[NTE5609](#) [NTE5656](#) [NTE56020](#) [NTE56022](#)