

SP5002 6 Channel Common Mode Filter



OBSOLETE DATE: 12/31/2020 PCN/ECN# ESU270-49
REPLACED BY: SP5001-04TTG for functional



Description

The SP5002 Series is a highly integrated Common Mode Filter (CMF) providing both ESD protection and EMI common mode noise filtering for systems using high speed differential serial interfaces, such as MIPI D-PHY.

The SP5002 Series can protect and filter three differential line pairs in a small RoHS-compliant TDFN-16 package, with cost and space savings over discrete solutions.

Pinout

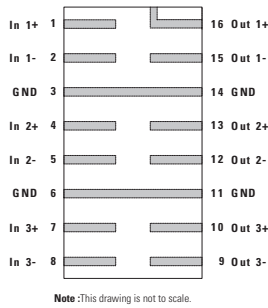

Features

- Large differential bandwidth > 2GHz
- High Common Mode Stop Band Attenuation:
 - > 25 dB at 700 MHz
 - > 30 dB at 800 MHz
- ±15kV ESD protection per channel (IEC 61000-4-2 Level 4, contact discharge and ±30kV air discharge)
- TDFN-16 4.00mm × 2.00mm × 0.75mm package with 0.50mm lead pitch
- RoHS-Compliant, Lead-Free packaging
- Moisture Sensitivity Level (MSL-1)

Functional Block Diagram

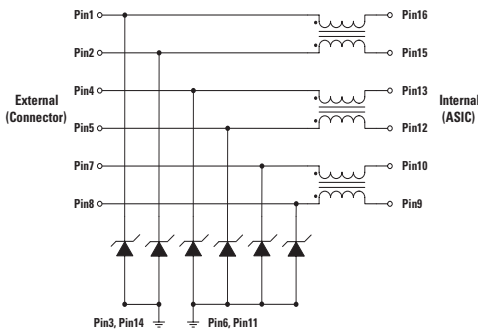

Applications

- MIPI D-PHY (CSI-2, DSI, etc) in Mobile Phones and Digital Still Cameras
- HDMI/DVI Display in Mobile Phones

Absolute Maximum Ratings

Symbol	Parameter	Value	Units
I_{DC}	DC Current Per Line	100	mA
P_{DC}	DC Package Power Rating	0.5	W
T_{OP}	Operating Temperature	-40 to 125	°C
T_{STOR}	Storage Temperature	-55 to 150	°C

CAUTION: Stresses above those listed in "Absolute Maximum Ratings" may cause permanent damage to the component. This is a stress only rating and operation of the component at these or any other conditions above those indicated in the operational sections of this specification is not implied.

Electrical Characteristics ($T_{OP}=25^{\circ}C$)

Parameter	Symbol	Test Conditions	Min	Typ	Max	Units
Channel Resistance	R_{CH}	Pins 1-16, 2-15, 4-13, 5-12, 7-10, and 8-9		8.0		Ω
Total Channel Capacitance	C_{TOTAL}	$V_{I/O} = 1.65V_{DC}$ Reverse Bias; $f=1MHz, 30mV_{AC}$		0.8	1.3	pF
Reverse Standoff Voltage	V_{RWM}				5.0	V
Breakdown Voltage	V_{BR}	$I_T=1mA$	6.0	8.0	10.0	V
Forward Voltage at I_F	V_F	$I_F=1mA$	0.4	0.7	1.5	V
Reverse Leakage Current	I_{LEAK}	$V_{I/O}=3.3V$		0.01	0.10	μA
Dynamic Resistance ^{2,3}	R_{DYN}	Positive ($tp=8/20\mu s$)		1.3		Ω
		Negative ($tp=8/20\mu s$)		0.7		
		TLP, $tp=100ns$, I/O to GND		0.36		
ESD Withstand Voltage ^{1,2}	V_{ESD}	IEC 61000-4-2 (Contact Discharge)	± 15			kV
		IEC 61000-4-2 (Air Discharge)	± 30			kV
Differential Mode Cutoff Frequency ²	F_{3dB}	$Z_{SOURCE}=50\Omega, Z_{LOAD}=50\Omega$		2.0		GHz
Common Mode Stop Band Attenuation ²	F_{σ}	$f=800MHz$		30		dB

Notes:

- ESD zapping at I/O pins (1,2,4,5,7,8) with respect to GND.
- Guaranteed by design.
- Transmission Line Pulse (TLP) with 100ns width and 200ps rise time.

Differential Mode Attenuation SDD21 vs. Frequency ($Z_{diff} = 100\Omega$)

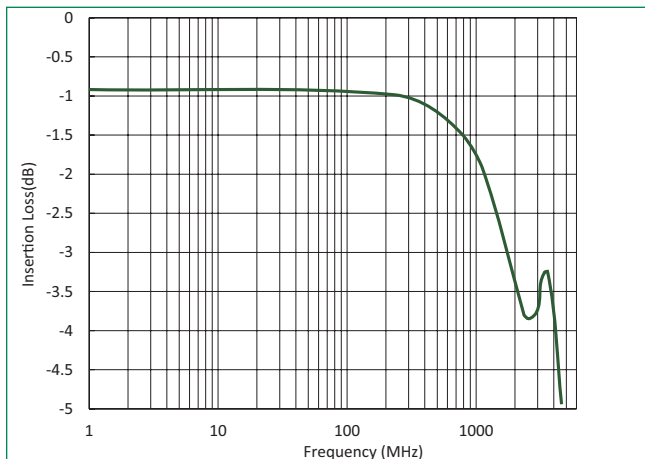

Common Mode Attenuation SCC21 vs. Frequency ($Z_{comm}= 50\Omega$)

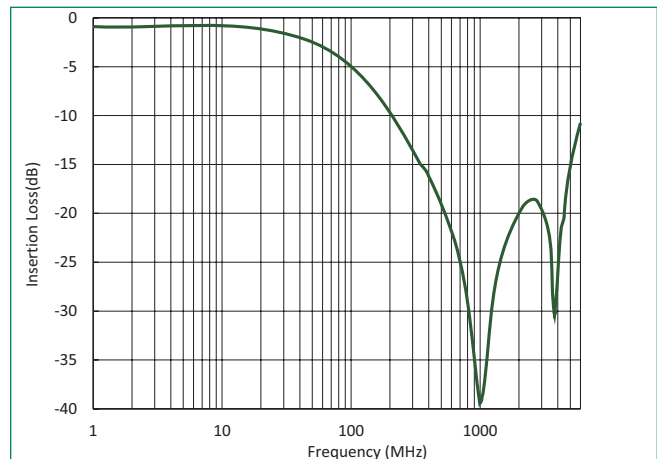

Differential Return Loss SDD11 vs. Frequency (Zdiff = 100Ω)

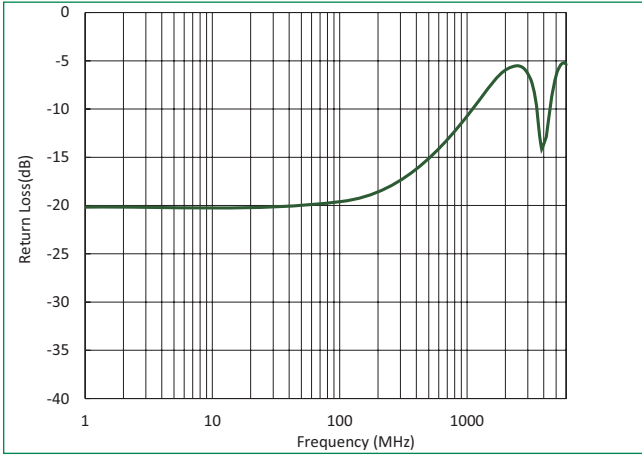

Differential Return Loss SDD22 vs. Frequency (Zdiff = 100Ω)

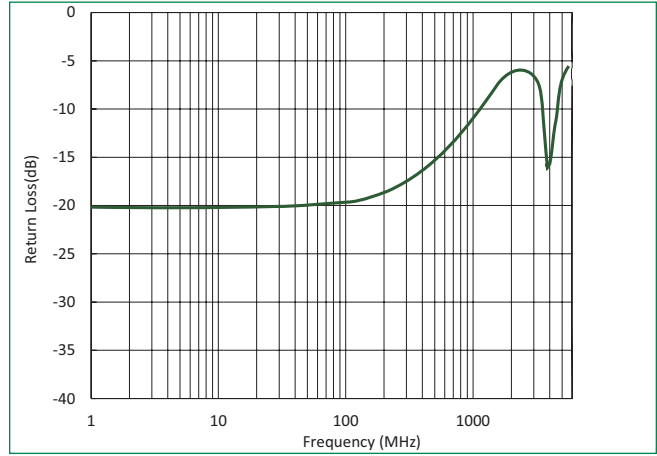

Transmission Line Pulsing (TLP) Plot

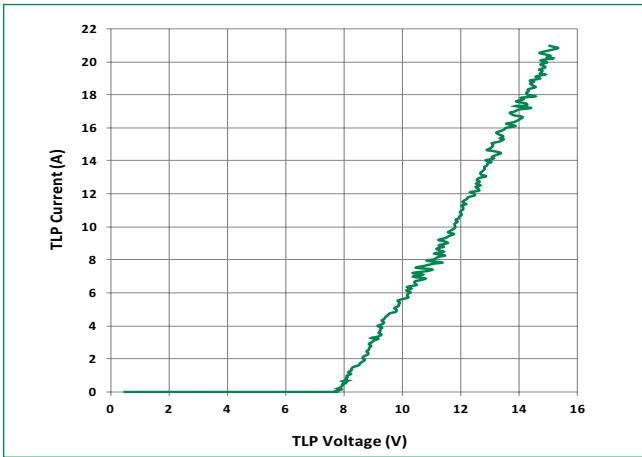

Soldering Parameters

Reflow Condition		Pb – Free assembly
Pre Heat	- Temperature Min ($T_{s(min)}$)	150°C
	- Temperature Max ($T_{s(max)}$)	200°C
	- Time (min to max) (t_s)	60 – 180 secs
Average ramp up rate (Liquidus) Temp (T_L) to peak		3°C/second max
$T_{s(max)}$ to T_L - Ramp-up Rate		3°C/second max
Reflow	- Temperature (T_L) (Liquidus)	217°C
	- Temperature (t_L)	60 – 150 seconds
Peak Temperature (T_p)		260 ^{+0.5} °C
Time within 5°C of actual peak Temperature (t_p)		20 – 40 seconds
Ramp-down Rate		6°C/second max
Time 25°C to peak Temperature (T_p)		8 minutes Max.
Do not exceed		260°C

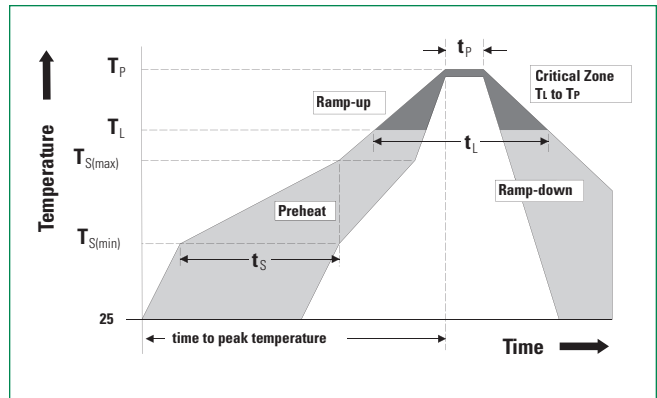

Product Characteristics

Lead Plating	Pre-Plated Frame
Lead Material	Copper Alloy
Substrate material	Silicon
Body Material	V-0 per UL 94 Molded Epoxy

- Notes:**
1. All dimensions are in millimeters
 2. Dimensions include solder plating.
 3. Dimensions are exclusive of mold flash & metal burr.
 4. Blo is facing up for mold and facing down for trim/form, i.e. reverse trim/form.
 5. Package surface matte finish VDI 11-13.

Ordering Information

Part Number	Package	Size	Min. Order Qty.
SP5002-06TTG	TDFN-16	4.0x2.0mm	3000

Part Numbering System

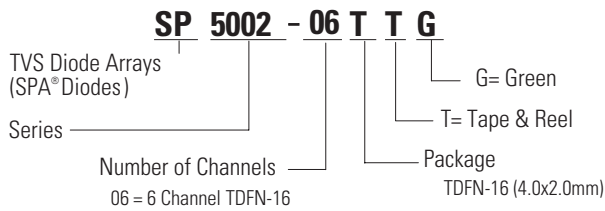

Part Marking System

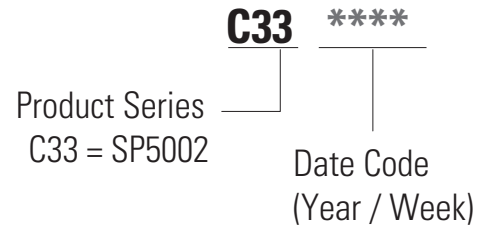

Package Dimensions – TDFN-16

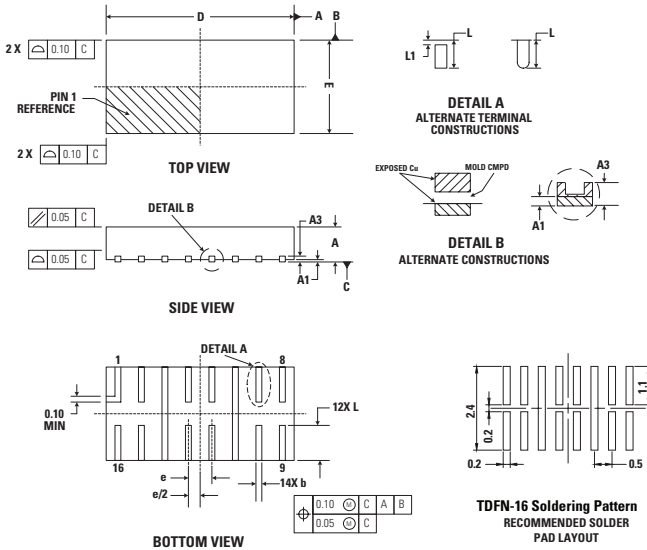

Symbol	TDFN-16 JEDEC MO-229			
	Millimeters		Inches	
	Min	Max	Min	Max
A	0.70	0.80	0.028	0.031
A1	0.00	0.05	0.00	0.002
A3	0.20 REF		0.008 REF	
b	0.15	0.25	0.006	0.010
D	3.95	4.05	0.156	0.159
E	1.95	2.05	0.077	0.081
e	0.50 BSC		0.020 BSC	
L	0.70	0.90	0.028	0.035
L1	0.05	0.15	0.002	0.006

Tape and Reel Specifications

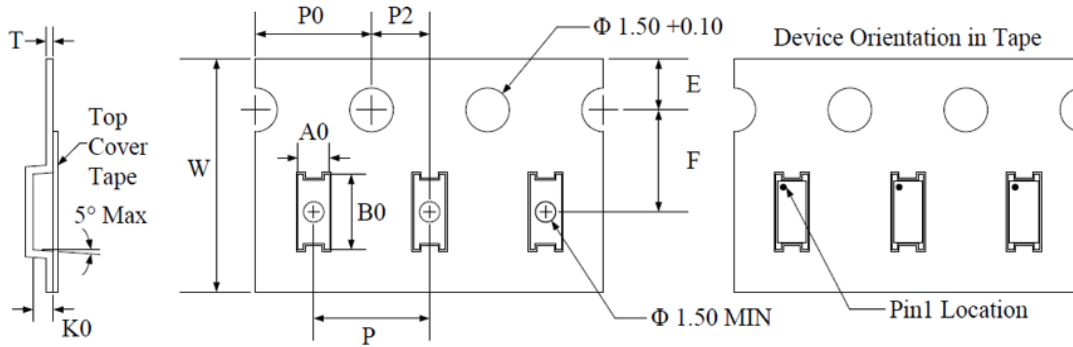

Symbol	W	A0	B0	K0	E	F	P	P0	P2	T
Dimensions (mm)	12.00 ± 0.30	2.30 ± 0.10	4.27 ± 0.08	1.00 ± 0.10	1.75 ± 0.10	5.50 ± 0.05	4.00 ± 0.10	4.00 ± 0.10	2.00 ± 0.05	0.30 ± 0.05

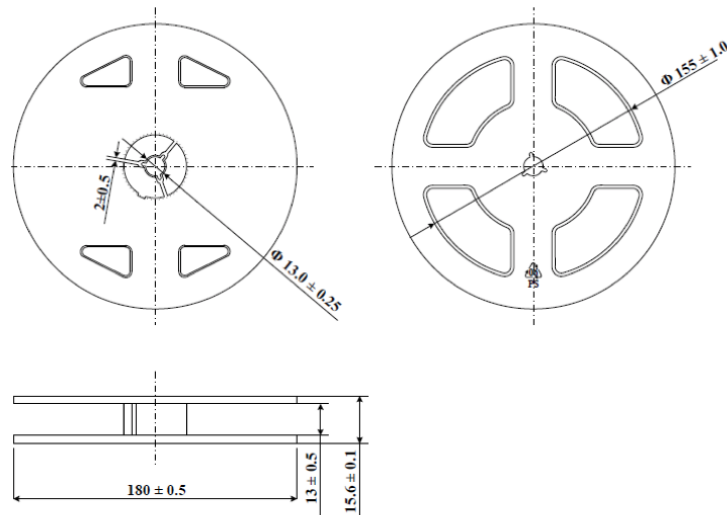

X-ON Electronics

Largest Supplier of Electrical and Electronic Components

Click to view similar products for [ESD Suppressors / TVS Diodes](#) category:

Click to view products by [Littelfuse](#) manufacturer:

Other Similar products are found below :

[60KS200C](#) [D12V0H1U2WS-7](#) [D18V0L1B2LP-7B](#) [82356050220](#) [D5V0M5U6V-7](#) [NTE4902](#) [P4KE27CA](#) [P6KE11CA](#) [P6KE39CA-TP](#)
[P6KE8.2A](#) [SA110CA](#) [SA60CA](#) [SA64CA](#) [SMBJ12CATR](#) [SMBJ8.0A](#) [SMLJ30CA-TP](#) [ESD112-B1-02EL](#) [E6327](#)
[ESD119B1W01005E6327XTSA1](#) [ESD5V0J4-TP](#) [ESD5V0L1B02VH6327XTSA1](#) [ESD7451N2T5G](#) [19180-510](#) [CPDT-5V0USP-HF](#)
[3.0SMCJ33CA-F](#) [3.0SMCJ36A-F](#) [HSPC16701B02TP](#) [D3V3Q1B2DLP3-7](#) [D55V0M1B2WS-7](#) [DESD5V0U1BL-7B](#) [DRTR5V0U4SL-7](#)
[SCM1293A-04SO](#) [ESD203-B1-02EL](#) [E6327](#) [SM12-7](#) [SMF8.0A-TP](#) [SMLJ45CA-TP](#) [CEN955 W/DATA](#) [82350120560](#) [82356240030](#)
[VESD12A1A-HD1-GS08](#) [CPDUR5V0R-HF](#) [CPDUR24V-HF](#) [CPDQC5V0U-HF](#) [CPDQC5V0USP-HF](#) [CPDQC5V0-HF](#) [D1213A-01LP4-7B](#)
[D1213A-02WL-7](#) [ESDLIN1524BJ-HQ](#) [5KP100A](#) [5KP15A](#) [5KP18A](#)