

合金贴片电阻承认书-RM 系列

Approval Specification Metal Current Sensing Chip Resistors-Type **RM**

承认书
APPROVAL SHEET

厂商：丽智电子有限公司

客户：_____

Supplier:

Customer:

核准 Approved by	审核 Checked by	制作 Prepared by

核准 Approved by	审核 Checked by	制作 Prepared by
地		

址：江
苏省南

南通市通州区康富路 789 号

Address: No. 789, Kang Fu Road Tongzhou District Nantong city Jiangsu province

Tel: 0086-0513-68856666

Fax: 0086-0513-68383688

地址：江苏省昆山市汉浦路 989 号

Address: No. 989, Hanpu Road Kunshan City Jiangsu Province

Tel:0086-0512-57780531

Fax:0086-0512-57789581

合金贴片电阻承认书-RM 系列

Approval Specification Metal Current Sensing Chip Resistors-Type **RM**

范围 (scope) :

1.1 适用于本公司所生产的无铅、无卤之合金贴片电阻 RM 系列

This specification applies to metal current sensing chip resistors which meet requirements of Pb free and halogen free.

1.2 符合 AEC-Q200 條款

The relevant provisions of the AEC-Q200

2 产品料号 (part number) :

2512 2W 1% 10mΩ

RM2512FBR010GM

<u>RM</u>	<u>2512</u>	<u>F</u>	<u>B</u>	<u>R010</u>	<u>G</u>	<u>M</u>
类型(Type) RM: 合金贴片电阻(Metal current sensing chip resistors)	尺寸(Size) 1206 2512	公差 Tolerance F=±1% G=±2% J=±5%	额定功率 Rated Power C= 3W B= 2W D=1.5W 1= 1W 2= 1/2W	阻值 Resistance value R002=2mΩ R010=10 mΩ 2L50=2.5mΩ	包装代码 Packing Code G= reel (卷装) V= bulk (散料) S= Double Standard Quantity (两倍卷盘标准包装量)	材料 Material M=MnCu N=NiCu S=CuMnSn

合金贴片电阻承认书-RM 系列

Approval Specification Metal Current Sensing Chip Resistors-Type *RM*

3 电阻本体字码标示(Marking on the Resistor's Body):

※ $\pm 1\%$, $\pm 2\%$, $\pm 5\%$ 的产品，以四字码标示，第一位字码 R 标示 10^{-3} ，后三位表示阻值的有效数字。

$\pm 1\%$, $\pm 2\%$, $\pm 5\%$ tolerance product: the marking is 4 digits, The first letter 'R' denotes 10^{-3} , The other three digitals declare resistance.

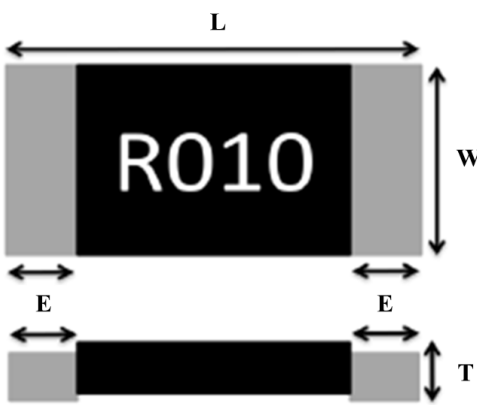

4 尺寸 (dimension) :

尺寸 dimension	 <p style="text-align: right;">单位 (unit) : mm</p>			
型别 Type	L	W	T	E
RM1206	3.2 ± 0.20	1.6 ± 0.20	0.60 ± 0.20 $(3\text{m}\Omega \leq R \leq 30\text{m}\Omega)$	0.50 ± 0.30 $(3\text{m}\Omega \leq R \leq 30\text{m}\Omega)$

合金贴片电阻承认书-RM 系列

Approval Specification Metal Current Sensing Chip Resistors-Type **RM**

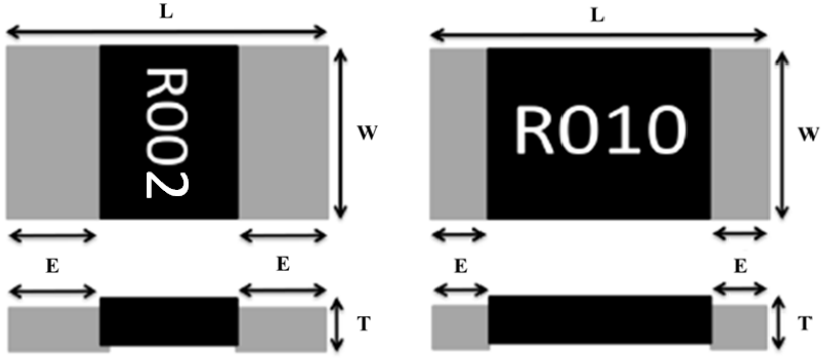
尺寸 dimension				
	单位 (unit) : mm			
型别 Type	L	W	T	E
RM2512	6.4±0.2	3.2±0.2	0.60±0.20	2.0±0.2 (R ≤ 2mΩ)
				0.9±0.2 (R > 2mΩ)

5 功率衰减曲线 (Derating Curve) :

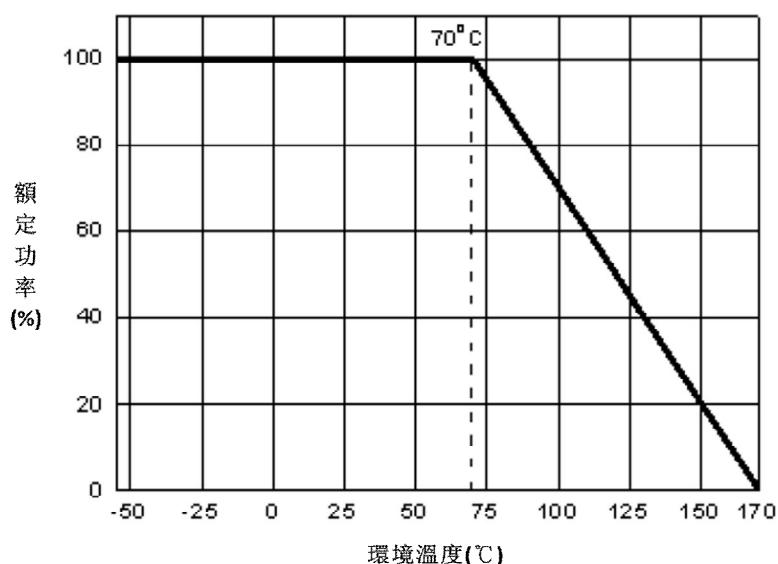

工作温度范围 (Operating Temperature Range) : -55°C~+170°C;

储存条件 (storage condition) : 5~35°C, 40~75%RH.

保存期限(Shelf Life): 2 年

合金贴片电阻承认书-RM 系列

Approval Specification Metal Current Sensing Chip Resistors-Type *RM*

6 电阻结构 (Construction) :

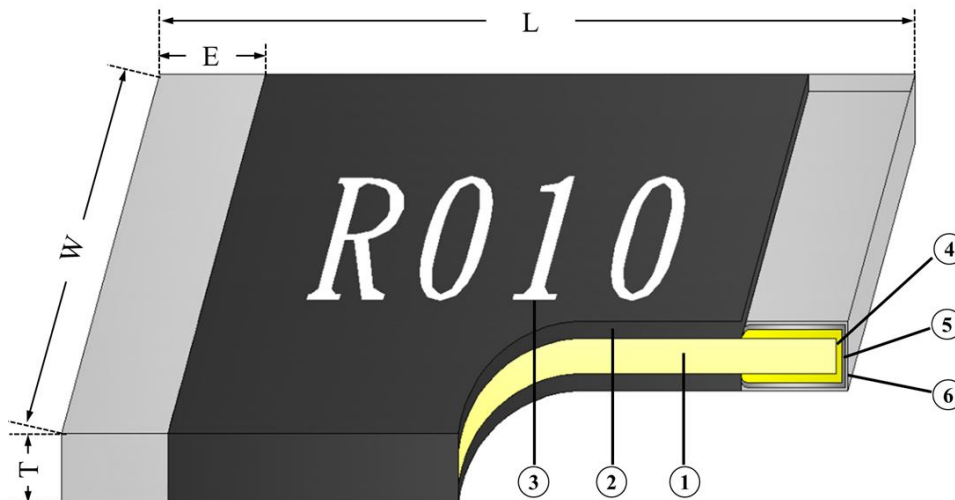

No.	结构 construction	主要材料 Major material
1	阻体 Resistive layer(Metal Alloy)	合金 Metal Alloy
2	保护层 Protective layer	环氧树脂 Epoxy
3	文字 Marking	环氧树脂 Epoxy
4	铜电极 Cu plating layer	铜 Cu
5	镍电极 Ni plating layer	镍 Ni
6	锡电极 Sn plating layer	锡 Sn

合金贴片电阻承认书-RM 系列

Approval Specification Metal Current Sensing Chip Resistors-Type **RM**

7 阻值范围及电气特性 (Resistance Range and Electrical Characteristics) :

型别 Type	额定功率 Rated Power	阻值范围 Resistance Range	温度特性TCR (ppm/°C)	绝缘耐压 Insulation Resistance
		F(±1%)、G(±2%)、J(±5%)		
RM1206	1/2W、1W	3mΩ~30mΩ	+25~+125°C: ±50	>100MΩ
			+25~+155°C: ±65	
RM2512	1W、1.5W、2W	1mΩ~50mΩ	+25~+125°C: ±50	>100MΩ
	3W	1mΩ~3 mΩ	+25~+155°C: ±65	
+25~+125°C: ±50			+25~+155°C: ±65	

备注 (remark) :

※ 额定电流计算公式 (The rated current is calculated by the following formula) :

$$I = \sqrt{P/R}$$

I : 额定电流 (Rated current) (V)

P : 额定功率 (Rated Power) (W)

R : 电阻阻值 (Resistance) (ohm)

※ 如果计算出的电流超过此型别的最大工作电流，则此型别的最大工作电流为此电阻的额定电流。

In case the value calculated by the formula exceed the maximum working current as above table, the maximum working current shall be regarded as rated current.

合金贴片电阻承认书-RM 系列

Approval Specification Metal Current Sensing Chip Resistors-Type **RM**

8 性能(Performance Specifications)

内容 Item	规格 Specification Limits	测试方法 Test Methods
温度系数 Temperature Coefficient	如规格表, As Spec. +25~+125°C: ±50ppm/°C +25~+155°C: ±65 ppm/°C	IEC60115-1 4.8
高温储存 High Temperature Exposure	<±1%	MIL-STD-202 Method 108
低温储存 Low Temperature operation	<±0.5%	IEC60115-1 4.23.4
温度循环 Temperature cycling	<±0.5%	JESD22 Method JA-104
短时间过负荷 Short-time overload	<±0.5%	IEC60115-1 4.13
耐湿特性 Biased Humidity	<±0.5%	MIL-STD-202 METHOD 103
负荷寿命 Operational life	<±1%	MIL-STD-202 METHOD 108
焊锡性 Solderability	最少 95%面积上锡(Min 95% coverage)	J-STD-002B test B
抗焊锡热 Resistance to soldering heat	<±0.5%	IEC60115-1 4.18
机械冲击 Mechanical Shock	<±0.5%	MIL-STD-202 METHOD 213
振动 Resistance to vibration	<±0.5%	MIL-STD-202 METHOD 204
端子弯曲 Board Flex	<±0.5%	AEC-Q200-005
端子强度 Terminal Strength	<±1%	AEC-Q200-006
冷热冲击 Thermal shock	<±0.5%	MIL-STD-202 METHOD 107
易燃 Flammability	/	UL-94
ESD 试验 ESD test	<±1%	AEC-Q200-002

合金贴片电阻承认书-RM 系列

Approval Specification Metal Current Sensing Chip Resistors-Type *RM*

9 包装规格 (Tapping Specification)

9.1 卷盘尺寸 (reel dimension)

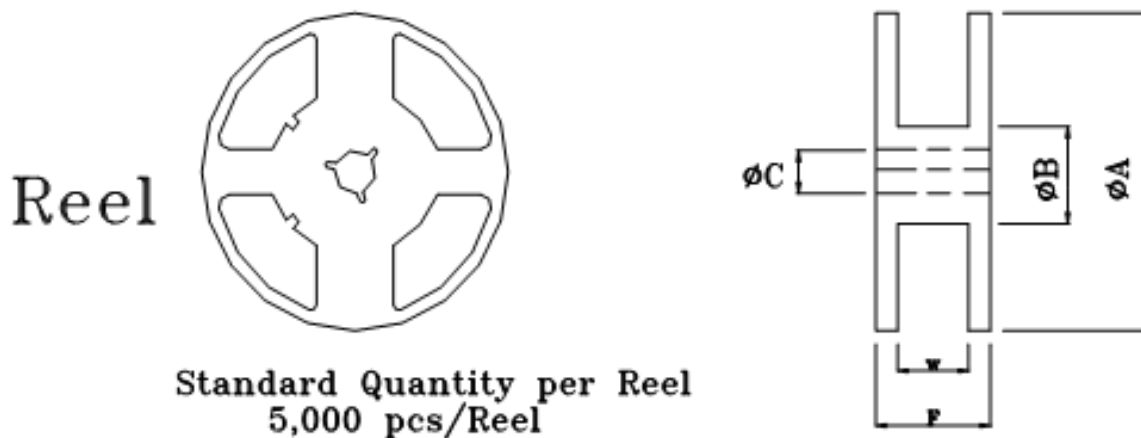

尺寸 Dimensions		A	B	C	F	W
RM1206	mm	178±2.00	60.00±1.00	13.50±0.50	11.40±0.10	9.00±0.30
	Inch	7.008±0.079	2.362±0.039	0.531±0.020	0.449±0.039	0.354±0.012
RM2512	mm	178±2.00	60.00±1.00	13.50±0.50	15.40±1.00	13.00±0.3
	Inch	7.008±0.079	2.362±0.039	0.531±0.020	0.606±0.039	0.512±0.012

※ 备注 (Remark) : (1) 2512 每卷 4,000 pcs

2512 Quantity per Reel 4,000 pcs/Reel

(2) 1206 每卷 5,000pcs

1206 Quantity per Reel 5,000 pcs/Reel

合金贴片电阻承认书-RM 系列

Approval Specification Metal Current Sensing Chip Resistors-Type **RM**

9.2 包装尺寸 (packing dimension)

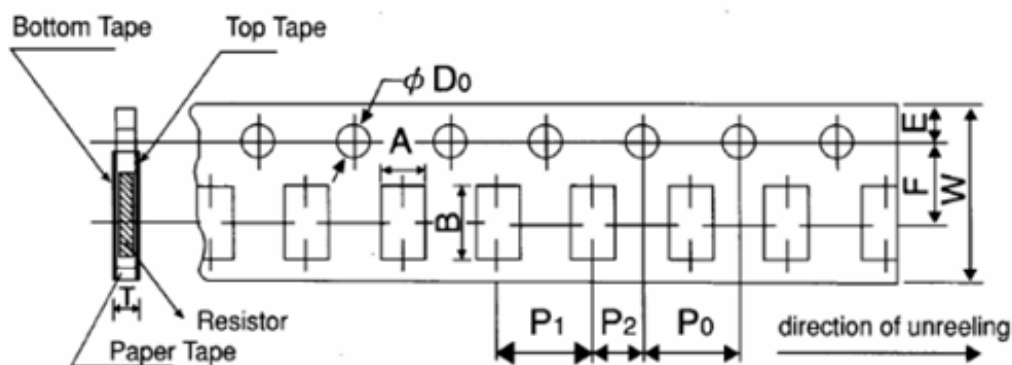

單位:mm

Packing	Type	A	B	W	F	E	P1	P2	P0	D0	T
Paper Tape	RM1206	2.0±0.15	3.6±0.2	8.0±0.2	3.5±0.05	1.75±0.1	4.0±0.1	2.0±0.05	4.0±0.1	1.50± $\begin{smallmatrix} 0.1 \\ 0.0 \end{smallmatrix}$	0.84±0.1

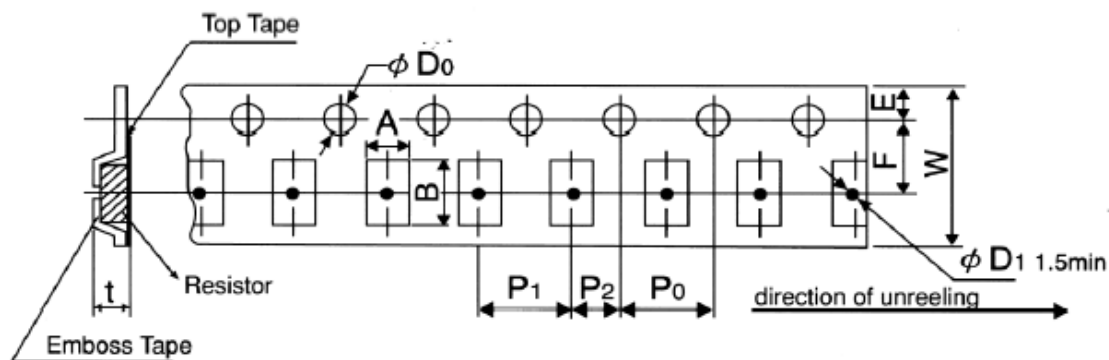

單位:mm

Packing	Type	A	B	W	F	E	P1	P2	P0	D0	T
Emboss	RM2512	3.6± $\begin{smallmatrix} 0.2 \\ 0.18 \end{smallmatrix}$	6.9±0.2	12.0±0.2	5.5±0.05	1.75±0.1	4.0±0.1	2.0±0.05	4.0±0.05	1.50± $\begin{smallmatrix} 0.1 \\ 0.0 \end{smallmatrix}$	1.00±0.15

合金贴片电阻承认书-RM 系列

Approval Specification Metal Current Sensing Chip Resistors-Type **RM**

10 信赖性测试 (Reliability Test Methods)

内容 Item	测试条件 Test Conditions
温度系数 Temperature Coefficient	$TCR = (R - R_0) / (t - t_0) R_0 \times 10^6 \text{ (ppm)}$ R ₀ 电阻在室温下的阻值(resistance at room temperature) R 电阻在+155℃或+25℃下的阻值(resistance at +155℃ or +25℃) t ₀ 室温(room temperature) t 测试温度 (test temperature +155℃ or +25℃)
高温储存 High Temperature Exposure	125℃下放置 1000H，试验结束 24±4 小时后量测试验前后阻值变化率。 1000 hrs. @T=125℃. Measure the variation of resistance at 24±4 hours after test conclusion. $\Delta R\% = \frac{R_2 - R_1}{R_1} * 100 \text{----- (\%)}$ R1 = 试验前阻值(resistance before test) R2 = 试验后阻值(resistance after test)
低温储存 Low Temperature operation	-55℃下放置 45 分钟，后量测试验前后阻值变化率。 45 min. @T=-55℃. Measure the variation of resistance after test conclusion. $\Delta R\% = \frac{R_2 - R_1}{R_1} * 100 \text{----- (\%)}$ R1 = 试验前阻值(resistance before test) R2 = 试验后阻值(resistance after test)
温度循环 Temperature cycling	-55℃&+125℃，循环 1000 次，试验结束 24±4 小时后量测试验前后阻值变化率。 1000Cycles (-55℃ to +125℃) Measurement at 24±4 hours after test conclusion. Measure the variation of resistance at 24±4 hours after test conclusion. $\Delta R\% = \frac{R_2 - R_1}{R_1} * 100 \text{----- (\%)}$ R1 = 试验前阻值(resistance before test) R2 = 试验后阻值(resistance after test)

合金贴片电阻承认书-RM 系列

Approval Specification Metal Current Sensing Chip Resistors-Type **RM**

内容 Item	测试条件 Test Conditions
短时间过负荷 Short-time overload	加载 5 倍的额定功率，时间 5 秒后测量试验前后的阻值变化率。 Applied 5.0 times of rated power for 5 second. Measure the variation of resistance. $\Delta R\% = \frac{R_2 - R_1}{R_1} * 100 \text{-----} (\%)$ R1 = 试验前阻值(resistance before test) R2 = 试验后阻值(resistance after test)
耐湿特性 Biased Humidity	加载 10%额定功率，85℃/85%RH, 持续通电 1000H,试验结束 24±4 小时后进行测试 1000 hours 85℃/85%RH. Note: Specified conditions: 10% of operating power. Measurement at 24±4 hours after test conclusion. $\Delta R\% = \frac{R_2 - R_1}{R_1} * 100 \text{-----} (\%)$ R1 = 试验前阻值(resistance before test) R2 = 试验后阻值(resistance after test)
负荷寿命 Operational life	电阻放入恒温箱中，温度 70±2℃，通电额定电流 1.5 小时，断电 0.5 小时；重复通断电至试验时间 1000 ⁺⁴⁸ / ₋₀ 小时。量测试验前后阻值变化率。 Put the specimen in a chamber at 70±2℃ temperature, and applied rated Current for 1.5H and rested for 0.5H repeatedly till total test time is 1000 ⁺⁴⁸ / ₋₀ . Measure the variation of resistance. $\Delta R\% = \frac{R_2 - R_1}{R_1} * 100 \text{-----} (\%)$ R1 = 试验前阻值(resistance before test) R2 = 试验后阻值(resistance after test)
焊锡性 Solder ability	沾助焊剂后浸入锡炉，锡炉温度 245±5℃，时间 2~3 秒 Dip the terminal in a flux and then dip into a soldering bath at 245±5℃ for 2~3sec.
抗焊锡热 Resist to soldering heat	沾助焊剂后浸入锡炉，锡炉温度 260±5℃，时间 10±1 秒, 测量试验前后的阻值变化率。 Dip the terminal in a flux and then dip into a soldering bath at 260±5℃ for 10±1sec. Measure the variation of resistance. $\Delta R\% = \frac{R_2 - R_1}{R_1} * 100 \text{-----} (\%)$ R1 = 试验前阻值(resistance before test) R2 = 试验后阻值(resistance after test)

合金贴片电阻承认书-RM 系列

Approval Specification Metal Current Sensing Chip Resistors-Type **RM**

内容 Item	测试条件 Test Conditions
机械冲击 Mechanical Shock	半正弦，100g's，震動6ms，速度12.3 ft/s100Hz，量测试验前后阻值变化率。 100g's , Normal duration is 6ms , half sine shock pulse .Measure the variation of resistance. $\Delta R\% = \frac{R_2 - R_1}{R_1} * 100 \text{-----} (\%)$ R1 = 试验前阻值(resistance before test) R2 = 试验后阻值(resistance after test)
振动 Resistance to vibration	5g's的力20分钟， 12个循环，测试频率从10-2000赫兹，量测试验前后阻值变化率。 5g's for 20min.12cycles, 10-2000Hz . Measure the variation of resistance. $\Delta R\% = \frac{R_2 - R_1}{R_1} * 100 \text{-----} (\%)$ R1 = 试验前阻值(resistance before test) R2 = 试验后阻值(resistance after test)
端子弯曲 Board Flex	弯曲2mm，60秒，量测试验前后阻值变化率。 Min 2mm deflection ,60sec. Measure the variation of resistance. Measure the variation of resistance.
端子强度 Terminal Strength	应用17.7N (1.8Kg)，时间60±1秒 Applied a 17.7N (1.8Kg) for 60±1seconds.
冷热冲击 Thermal shock	温度-55/+125℃，周期数是 300,设备安装。最大传输时间是 20 秒，停留 15 分钟。 use -55/+125℃, Number of cycles is 300. Devices mounted. Maximum transfer time is 20 seconds. Dwell time is 15 minutes. Air -Air $\Delta R\% = \frac{R_2 - R_1}{R_1} * 100 \text{-----} (\%)$ R1 = 试验前阻值(resistance before test) R2 = 试验后阻值(resistance after test)
易燃 Flammability	V-0 or V-1可接受的，電氣特性測試不要求 V-0 or V-1are acceptable, Electrical test not required.
ESD 试验 ESD test	加载规定静电电压2KV.2次/间隔1秒， Other:2KV, 2times/1s

合金贴片电阻承认书-RM 系列

Approval Specification Metal Current Sensing Chip Resistors-Type *RM*

11 上胶带剥离力测试 (Peel force of top cover tape)

上胶带以 300mm/分钟的速度，沿 165~180 度角的方向进行剥离，如下图所示。纸带的剥离力范围为 10g~70g; 载带的剥离力范围为 30~100g

The top cover tape is pulled at a speed of 300 mm/min with the angle between the tape during peel and the direction of unreeling maintained at 165 to 180 degree as following picture. The peel force of paper carrier tape shall be 0.1N to 0.7N(10 to 70 g), the peel force of plastic carrier tape shall be 0.3N to 1N (30 to 100 g)

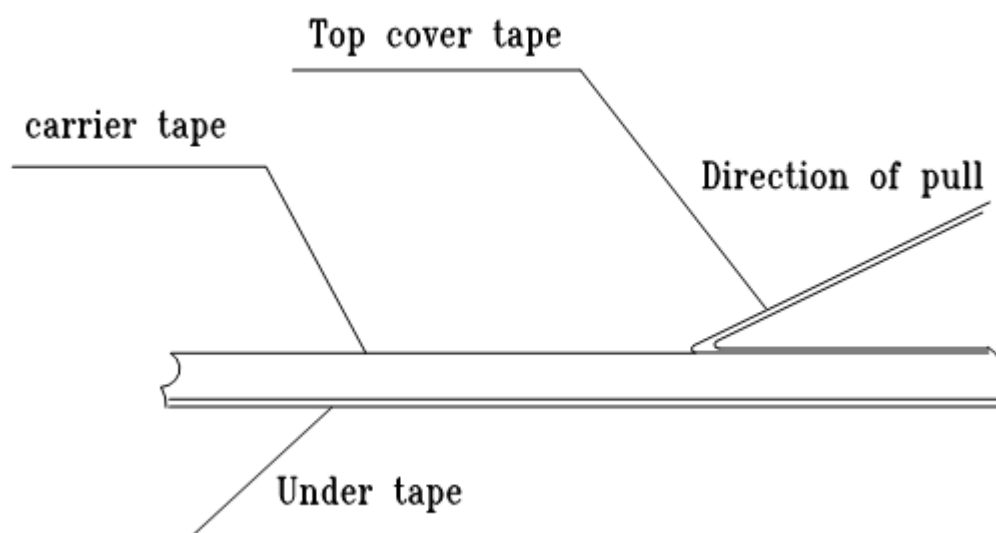

合金贴片电阻承认书-RM 系列

Approval Specification Metal Current Sensing Chip Resistors-Type **RM**

12 焊接 (soldering)

12.1 建议焊盘尺寸 (Recommended Solder Pad Dimension)

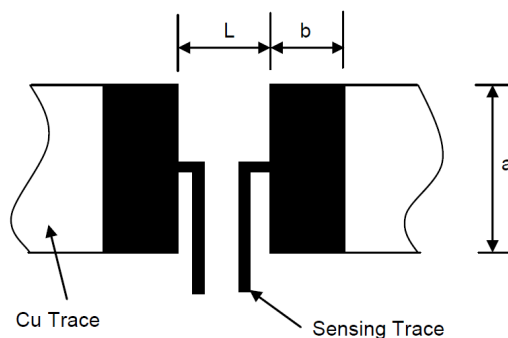

單位:mm

尺寸 Dimensions	阻值範圍 Resistance Range	a	b	L
RM1206	3mΩ~30mΩ	1.80	1.70	1.60
RM2512	1mΩ~2mΩ	4.00	3.10	1.80
	3mΩ~50mΩ	4.00	2.10	4.10

12.2 建议回流焊曲线 (Recommend reflow soldering profile)

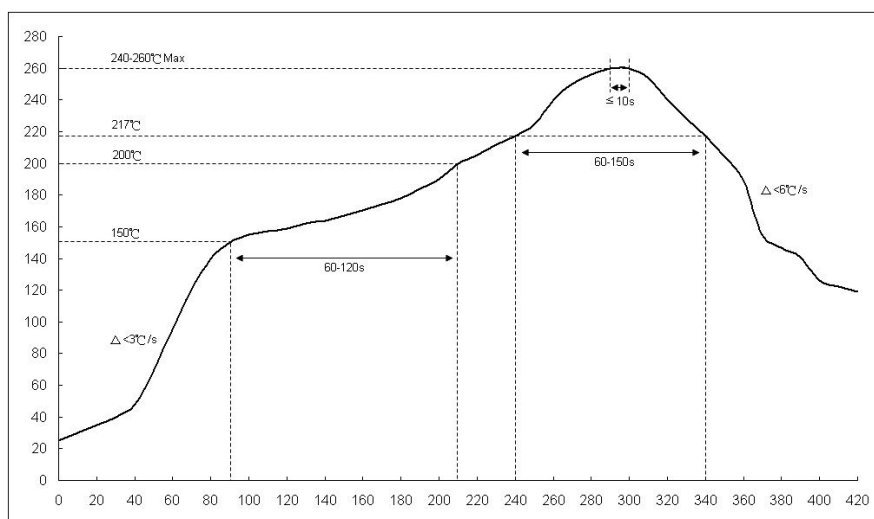

合金贴片电阻承认书-RM 系列

Approval Specification Metal Current Sensing Chip Resistors-Type *RM*

12.3 建议波峰焊曲线 (Recommend wave soldering profile)

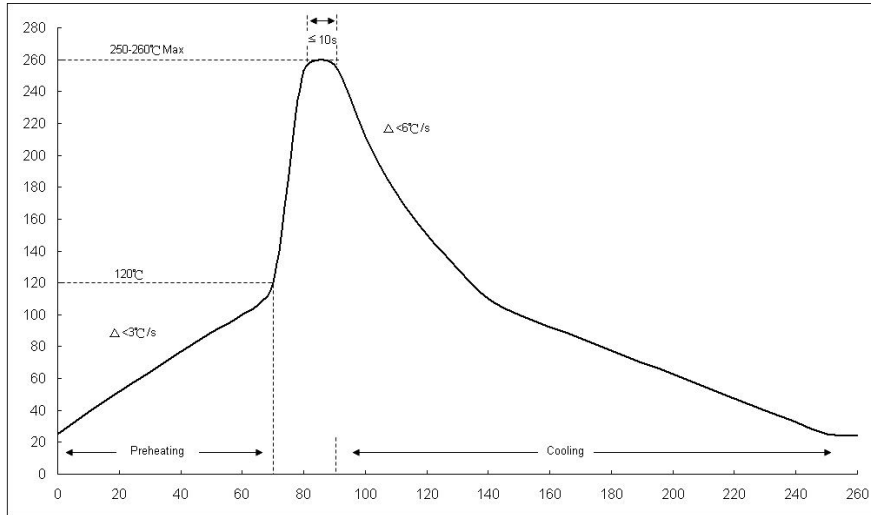

12.4 手工焊温度 (hand soldering temperature)

烙鐵溫度 $350\pm 10^{\circ}\text{C}$ ，3 秒之內，避免烙鐵接觸電阻本體

The iron temperature is $350\pm 10^{\circ}\text{C}$, hand soldering time less than 3S. Avoid solder iron tip direct touch the components body

★所有產品規格改變不再另行通知

★All product specification and data are subject to change without notice.

X-ON Electronics

Largest Supplier of Electrical and Electronic Components

Click to view similar products for [Current Sense Resistors - SMD category](#):

Click to view products by [LIZ manufacturer](#):

Other Similar products are found below :

[CRL0603-FW-R700ELF](#) [PFS35-200RF1](#) [CD2015FC-0.10-1%](#) [PR2512FKF7W0R004L](#) [RC1005F124CS](#) [RL73K3AR56JTDF](#) [RL7520WT-R001-F](#) [RL7520WT-R009-G](#) [RL7520WT-R020-F](#) [LRC-LR2010LF-01-R033J](#) [LRC-LR2512LF-01-R820J](#) [65709-330](#) [SP1R12J](#) [RL7520WT-R039-G](#) [RL7520WT-R002-F](#) [RL7520WT-R005-F](#) [KRL1632E-C-R200-F-T5](#) [KRL1632E-C-R200-F-T1](#) [Y14880R02000B9R](#) [RLP73M2AR075FTDF](#) [SR731ERTTP5R10F](#) [SR731ERTTP100J](#) [SR731ERTTP6R80F](#) [SR731ERTTP3R9J](#) [SR731ERTTP8R2J](#) [SR731ERTTP2R0J](#) [SR731ERTTP4R7J](#) [SR731ERTTP9R1J](#) [SR731ERTTP1R0J](#) [SR731ERTTP2R2J](#) [SR731ERTTP5R1J](#) [SR731ERTTP6R8J](#) [SR731ERTTP9R10F](#) [FCSL64R007JER](#) [73L4R10G](#) [73L4R75G](#) [73L4R33G](#) [73M1R051F](#) [73WL4R020J](#) [73L2R68J](#) [73L2R22J](#) [73L2R33J](#) [CC1512FC-0.015-5%](#) [ULRG2-2512-R0075-F-LF-SLT](#) [ULR3N-R00075FT2](#) [ULR3N-R0009FT2](#) [SLN3TTED80L6F](#) [JW104X15X4](#) [JW105X19X5](#) [HVR06FTEV2403](#)