



重庆市灵龙电子有限公司

CHONGQING LINGLONG ELECTRONIC CO., LTD.

承 认 书

SPECIFICATION FOR APPROVAL

客 户Customer:

项目名称Project:

规格型号Part No:

S3070P-300070720-0002

客 户 确 认/ Customer Approved	
料 号/ Part No.	签 章/ Signatures

地址: 中国重庆市北部新区经开园灵龙工业区
Add: Linglong Industrial Zone, Northern Area of
CETZ, Chongqing P.R.China.
电话/Tel: 86-23-67463788
传真/Fax: 86-23-67463766
Http: [//www.lnlon.com](http://www.lnlon.com)
E-mail: lnlon@lnlon.com

存货编码/Stock	30301000012
拟制/Drawn	魏友平
审核/Check	江丰春
批准/Approved	章启策

	产品规格书/specification	No	LL-3-J-19000
		版本Revision	A. 2
	存货编码/Stock code.: 30301000012	页码Page	2 of 11
		日期Date	2018-7-11

1. 适用范围/General

本规格书适用于重庆灵龙电子有限公司所提供的产品: S3070P-300070720-0002

The specification is applicable to lnlon's part: S3070P-300070720-0002

2. 使用条件/Operating condition

No	项目/Item	规格/Specification
2-1	额定电压 Rated voltage	2. 7V DC
2-2	使用电压范围 Operating voltage	2. 3~3. 2V DC
2-3	旋转方向 Rotationo rientation	CW(clockwise)
2-4	马达位置 Motor position	全方位 All positions
2-5	额定负荷 Rated load	摆锤重 (按外型图规定) Vibratino Weight (as specified in outline drawing)
2-6	使用环境 Operating environment	-20~70℃, 0~95% (RH) 无水气凝结 No coagulation of moisture
2-7	保存环境 Storage environment	-40~85℃, 0~95% (RH) 无水气凝结 No coagulation of moisture

3. 测量条件/Measuring condition

一般情况下, 马达可以在5~35℃, 相对湿度30~90% (RH) 的环境中测试。为了保证一致性, 测试应在下表规定内进行Normally, it should be tested under 5~35℃, 30~90% (RH) . To ensure the coherence, it must be tested according to the below chart.

No	项目/Item	规格/Specification
3-1	温度 Temperature	20±2℃
3-2	湿度 Humidity	65%±5% RH
3-3	位置 Motor position	马达水平放置/lay motor horizontally

4. 机械要求/Mechanical specification

No	项目/Item	规格/Specification	测定条件/备注 Measuring condiction/Remark
4-1	外观 Appearance	不应有明显的机械损伤、锈蚀和固定夹松动等现象 No evidence of machanical damage, rust corrision, loosening of the grip and so on.	目视检查 Visual examination
4-2	轴向间隙 Shaft end play	0. 3mm MAX	轴沿着轴向可以移动的距离 Distance of axial play on shaft

	产品规格书/specification		No	LL-3-J-19000
			版本Revision	A. 2
	存货编码/Stock code.: 30301000012		页码Page	3 of 11
			日期Date	2018-7-11

No	项目/Item	规格/Specification	测定条件/备注 Measuring condiction/Remark
4-3	尺寸 Dimensions	见外形图 As specified in outline drawing	使用游标卡尺或千分尺测量 Test with vernier caliper or micrometer
4-4	振子重量 Mass	0.23g±10%	精密天平scale
4-5	电机质量 Mass	0.6g±10%	精密天平scale
4-6	振子轴向拔出力 Pulling force along vibration shaft	3kgf Min	破坏性测试, 对振子沿着轴向施加推力 Devastating test, bring pushing force to the Bracket along the horizontal shaft.



5. 性能特征/Performance and characteristics

No	项目/Item	规格/Specification	测定条件/备注 Measuring condiction/Remark
5-1	额定转速 Rated speed	14000±2500rpm	在额定电压和额定负载下。 At rated voltage and rated load .
5-2	额定电流 Rated current	85 mA Max	
5-3	启动电压 Starting voltage	2.3V DC Max	在额定负载下转子的任意位置。 At rated load any position of rotor.
5-4	堵转电流 Stall current	90 mA Max	在额定电压下锁定振动轮, 测电机电流 Measure current at locked counterweight in rated voltage
5-5	端子阻抗 Terminal resistance	33Ω ±6Ω	在两接触脚之间测量 Test between the two touch pins
5-6	绝缘电阻 Insulation resistance	1MΩ Min	在50V 直流电压下, 端子和机壳间进行测量 Test between terminal and case at DC 50V
5-7	机械噪音 Mechanical noise	小于45分贝. A计权 45db(A)Max 45	见下图: See below

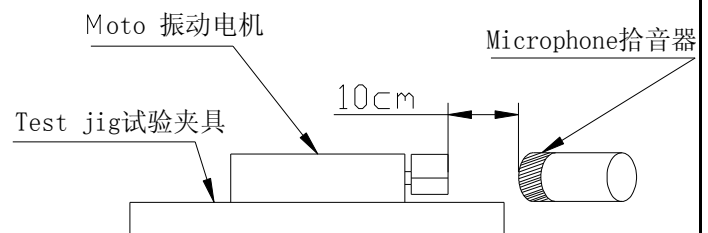
额定电压下, 背景噪声≤25 dB(A), 电机轴向水平固定在测试夹具上(100g), 拾音器沿轴向正对电机平面, 距离10cm
At rated voltage and scene noise as 25dB(A)Max, the shaft is horizontally fastened to the test jig(100g). The Microphone faces the plane of motor along the shaft. The distance is 10cm.



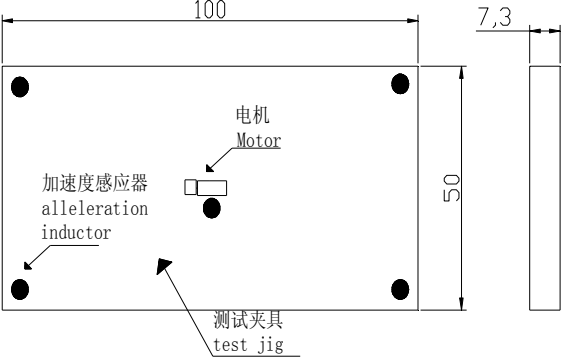

	产品规格书/specification	No	LL-3-J-19000	
		版本Revision	A. 2	
	存货编码/Stock code.: 30301000012	页码Page	4 of 11	
		日期Date	2018-7-11	

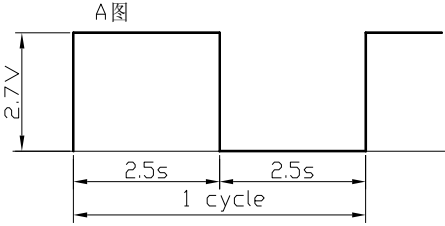
5-8	振动量 Vibration quantity	$\geq 0.4G$ (5个点平均值)	见下图 See beow
	<p>额定电压下,电机固定在100*50*7.3的铝制板夹具(约100g)的中心,夹具平放在海绵上,将加速度感应器用双面胶固定在对位置测试五个点位的振动强度,取平均值得出最终振动量。(如图所示).使用VM-83振动仪,参数设置如下: 加速度(m/s²): 30 HPF(HZ):50 LPF(HZ):300 探测方式:EQ (P-P) -Max Hold</p> <p>Under the rated voltage, the motor is fixed on the aluminum plate fixture 100*50*7.3 (about 100g) in the center of the fixture flat on the sponge, the acceleration sensor is fixed with double-sided adhesive tape at the position corresponding to test the vibration intensity of five points, averaging out the final amount of vibration. Using the VM-83 vibrometer, the parameters are set as follows: Acceleration(m/s²): 30 HPF(HZ):50 LPF(HZ):300 Detection mode:EQ (P-P) -Max Hold</p>		 <p>振子摆头方向:轴向 Vibration shaking direction: along shaft</p> 

6. 可靠性/Reliability			
No	项目/Item	测试条件/Specification	判定标准/Judgment
6-1	寿命 Life	<p>A图</p>  <p>6-1-1寿命试验 按A图常温常湿下共循环300000次 Cycle 300000times in the ordinary temperature and humidity.</p>	<p>电气性能变化率表: 1) 额定转速:指标不低于初始值-30%; 不高于初始值+50% 2) 额定电流:指标在初始值$\pm 30\%$以内。 3) 起动电压:不大于2.3V直流电压。 1) Rated speed:Data-30% Initial Min, Data+50% Initial Max. 2) Rated current:Data$\pm 30\%$ Max. 3) Starting voltage: 2.3V DC Max.</p> <p>每20000次后进行电气性能测试,循环100000次后,电机应符合电气性能变化率表要求,300000次后电机能运转。 every 20,000 cycles to measure the all electrical characteristic After100000, the motor's performance shoud accord with below requirements: After 300,000 cycles The vibrator should operate</p>
		6-1-2 高温寿命试验 按A图55℃下共循环53000次 Cycle 53000times in the 55℃.	每20000次后进行电气性能测试,电机性能应符合电气性能变化率表要求。 every 20,000 cycles to measure the all electrical characteristic。 After 53000, the motor's performance shoud accord with below requirements:
		6-1-3 低温寿命试验 按A图-20℃下共循环53000次 Cycle 53000times in the -20℃.	每20000次后进行电气性能测试,电机性能应符合电气性能变化率表要求。 every 20,000 cycles to measure the all electrical characteristic。 After 53000, the motor's performance shoud accord with below requirements:

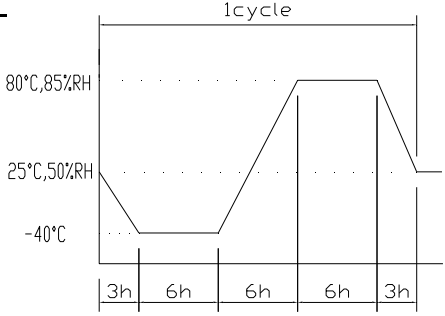
	产品规格书/specification		No	LL-3-J-19000
			版本Revision	
	存货编码/Stock code.: 30301000012		页码Page	5 of 11
			日期Date	2018-7-11

No	项目/Item	测试条件/Specification	判定标准/Judgment
6-2	低温贮存放置 Low temperature storage test	温度Temperature: $-40 \pm 2^{\circ}\text{C}$ 时间Time: 96h	电气性能变化率表: 1) 额定转速: 指标不低于初始值-30%; 不高于初始值+50% 2) 额定电流: 指标在初始值 $\pm 30\%$ 以内。 3) 起动电压: 不大于2.3V直流电压。 1) Rated speed: Data-30% Initial Min, Data+50% Initial Max. 2) Rated current: Data $\pm 30\%$ Max. 3) Starting voltage: 2.3V DC Max.
6-3	高温贮存放置 High temperature storage test	温度Temperature: $80 \pm 2^{\circ}\text{C}$ 时间Time: 96h	
6-4	湿度放置 Humidity exposure	温度Temperature: $60 \pm 2^{\circ}\text{C}$ 湿度Humidity: 90~95%RH 放置时间Exposure time: 96h	
6-5	热冲击贮存试验 High/Low temperature humidity cycle test	 <p>温度: $-40^{\circ}\text{C} \leftrightarrow 80^{\circ}\text{C}$, 湿度: 85% Temperature: $-40^{\circ}\text{C} \leftrightarrow 80^{\circ}\text{C}$ humidity: 85% Test cycle: 6 cycles</p>	在常温常湿下放置4h后, 电机性能应符合电气性能变化率表要求 After 4h exposure in the ordinary temperature and humidity, the motor's performance should accord with below requirements:
6-6	热冲击试验 Thermal shock resistance test	温度 -40°C 至 80°C , 时间30Min, 共循环50次 ($-40^{\circ}\text{C} \leftrightarrow 80^{\circ}\text{C}$), duration time 30 minutes 50 cycles	在常温常湿下放置4h后, 电机性能应符合电气性能变化率表要求 After 4h exposure in the ordinary temperature and humidity, the motor's performance should accord with below requirements:
6-7	振动 Vibration	全振幅Full swing: 1.5mm (p-p) 频率Frequency: 10 to 55Hz 周期Cycle: 20min (10~55~10Hz) 方向Orientation: x、y、z 时间Time: 2h	在常温常湿下放置4h后, 电机性能应符合电气性能变化率表要求 After 4h exposure in the ordinary temperature and humidity, the motor's performance should accord with below requirements:
6-8	自然跌落 Free fall	试验状态: 将马达固定在约100克(包括马达本身)的物体上, 落向水泥地面。 高度: 1.5m 方向: $\pm x$, $\pm y$, $\pm z$ 次数: 每个方向2次 Test state: Fasten the motor onto a object(100g) and then let it fall down to the ground. Height: 1.5m Orientation: $\pm x$, $\pm y$, $\pm z$ Times: 2times per orientation	在常温常湿下放置4h后, 电机性能应符合电气性能变化率表要求 After 4h exposure in the ordinary temperature and humidity, the motor's performance should accord with below requirements:

	产品规格书/specification	No	LL-3-J-19000
		版本Revision	A. 2
	存货编码/Stock code.: 30301000012	页码Page	6 of 11
		日期Date	2018-7-11

7. 环境管理物质/Environmental management materials:

7.1 本产品应符合RoHS指令要求和无卤素要求。

The product should be in compliance with RoHS requirements:

* 镉及其化合物最大允许含量为100PPM

Cadmium and Compound:100PPM Max

* 铅及其化合物最大允许含量为1000PPM

Lead and Compound:1000PPM Max

* 汞及其化合物最大允许含量为1000PPM

Hydrargyrum and Compound:1000PPM Max

* 六价铬及其化合物最大允许含量为1000PPM

+6 Chromium and Compound:1000PPM Max

* 多溴联苯及其化合物最大允许含量为1000PPM

PBB and Compound:1000PPM Max

* 多溴二苯醚及其化合物最大允许含量为1000PPM

PBDE and Compound:1000PPM Max

* 氯溴两种卤素之和最大允许含量为1500PPM

The allowed content of Cl, Br is 1500PPM Max for total.

* 氯卤素最大允许含量为900PPM

The allowed content of Cl is 900PPM Max.

* 溴卤素最大允许含量为900PPM

The allowed content of Br is 900PPM Max.

7.2 本品含有以下物质, 是RoHS指令豁免项

The product contains below materials, which are released from RoHS:

NO	品名 Part No.	材质 Material	含有物质 Substance included	最大允许含量 Max content	部品重量 Parts Weight
1	含油轴承 Bearing with Oil	铜合金 Copper alloy	铅 Lead	40000PPM	≈0.016g



产品规格书/specification

N₂

LL-3-J-19000

版本Revision

A. 2

存货编码/Stock code.: 30301000012

页码Page

7 of 11

日期Date

2018-7-11

8. 批号说明/Indication of Lot No.

L 10 X P a (2010-10-25 1线)

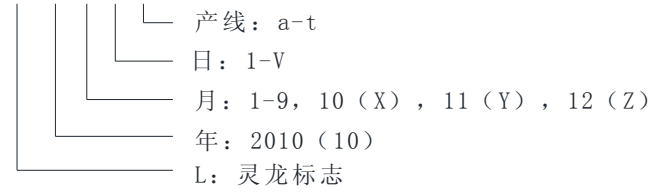

注: 产线特性 (即为圆柱/驱动/贴片) 根据产品型号而定
喷码长度根据 $\phi 4$ 马达长度设定

日期	1	2	3	4	5	6	7	8	9	10	11	12	13	14	15	16
打印	1	2	3	4	5	6	7	8	9	A	B	C	D	E	F	G
日期	17	18	19	20	21	22	23	24	25	26	27	28	29	30	31	
打印	H	J	K	L	M	N	P	R	S	T	V	W	X	Y	Z	
产线	1	2	3	4	5	6	7	8	9	10	11	12	13	14	15	16
打印	a	b	c	d	e	f	g	h	j	k	l	m	n	p	r	s
产线	17	18	19	20												
打印	t	v	w	x												

9. 包装图/Packing drawing

9.1 最小包装/Smallest packing condition

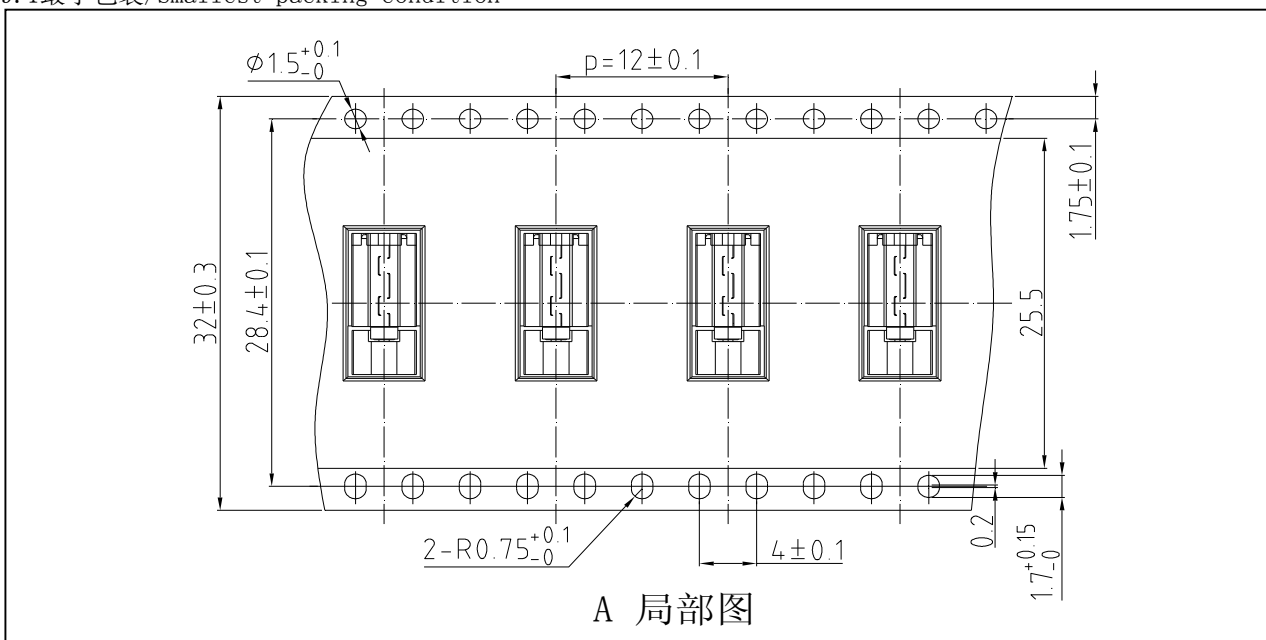



产品规格书/specification

N₂

LL-3-J-19000

版本Revision

A. 2

存货编码/Stock code.: 30301000012

页码Page

8 of 11

日期Date

2018-7-11

9.2 纸板包装 Cardboard Packing Condition

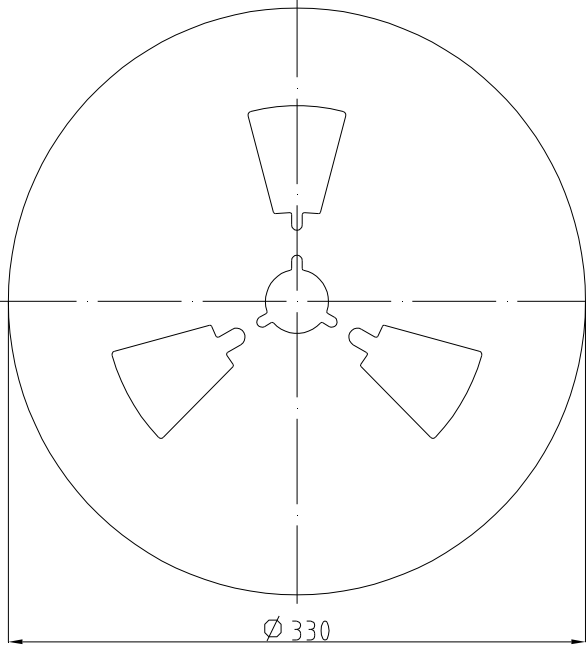
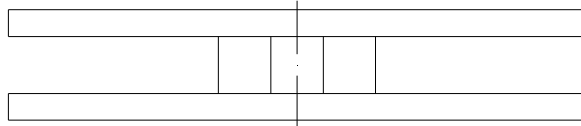

卷盘拆卸方向

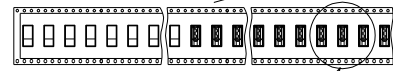

A 局部图

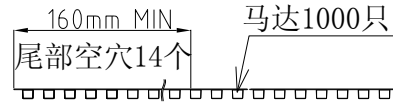

160mm MIN
尾部空穴14个

马达1000只



卷盘尾部

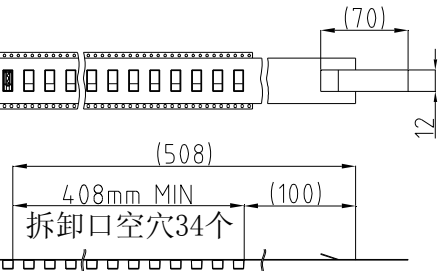
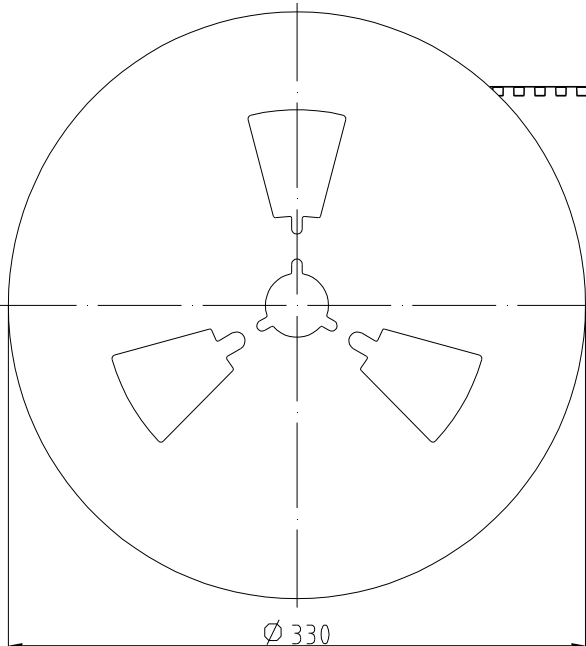
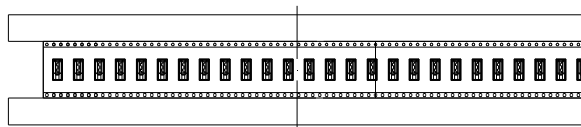

(508)
408mm MIN
拆卸口空穴34个

(70)
12

(100)



卷盘拆卸口



产品规格书/specification

No

LL-3-J-19000

版本Revision

A. 2

存货编码/Stock code.: 30301000012

页码Page

9 of 11

日期Date

2018-7-11

9.3 最终包装 Final Packing Condition

1000只/卷x5卷=5000只

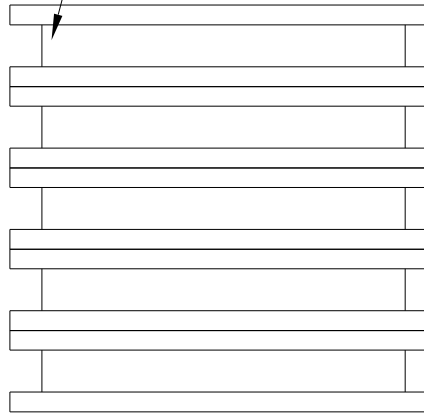

双层波纹纸

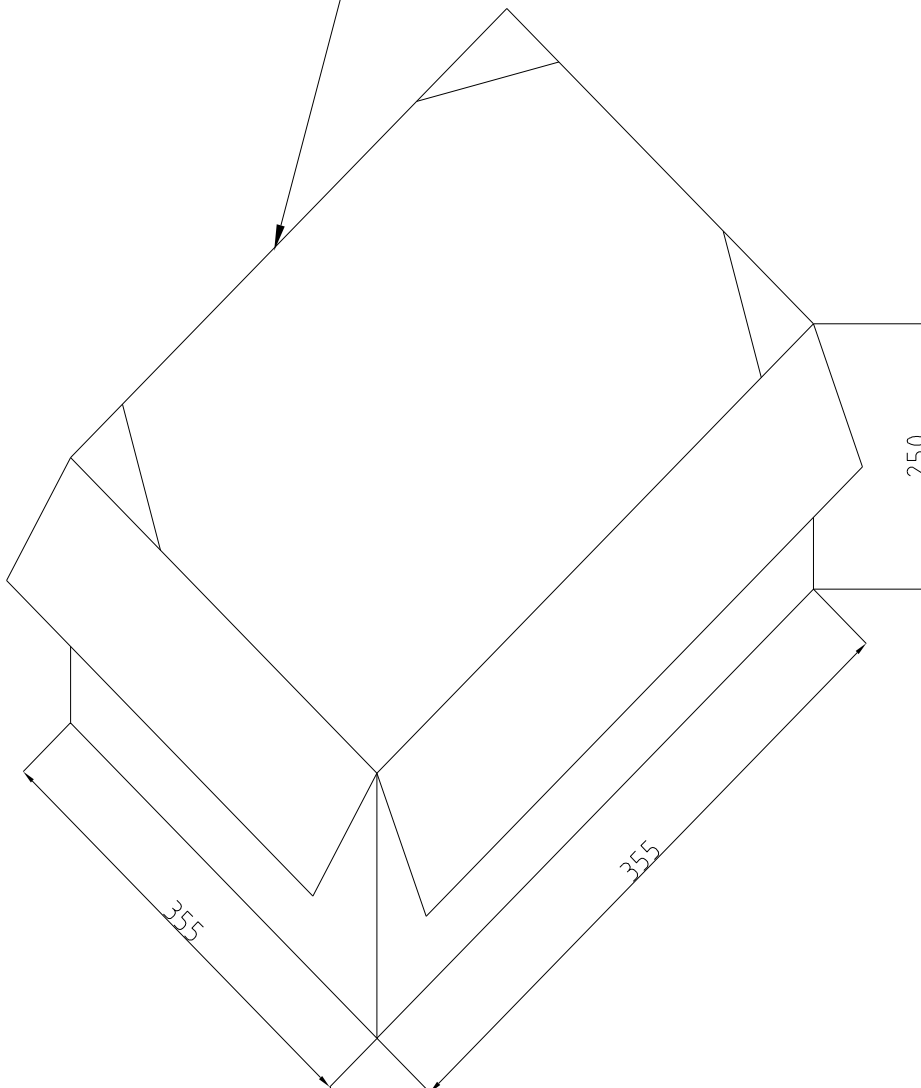

1. 外形尺寸图

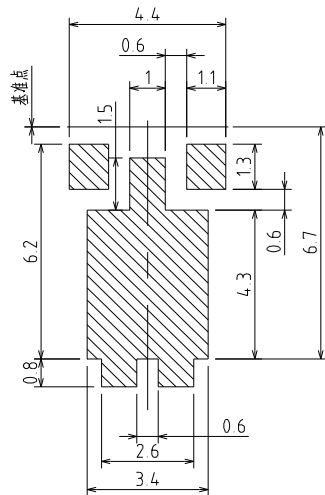
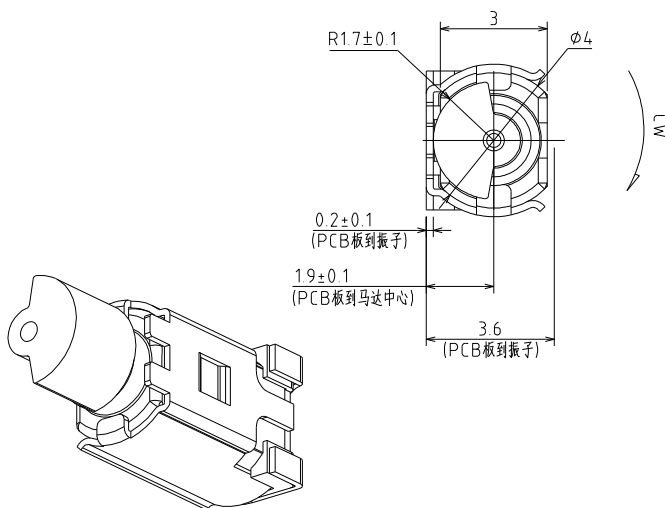
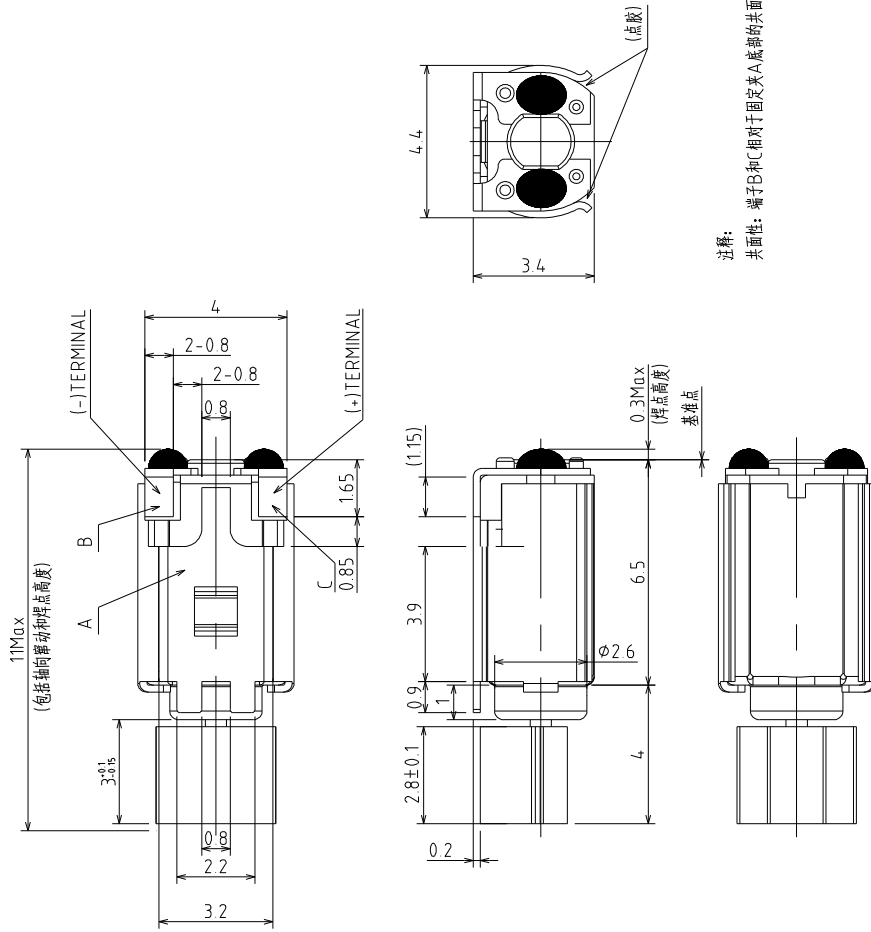

建议安装图

日期 DATE	修订内容 Revision	绘制 Drawn	审核 Check	重庆市灵龙电子有限公司 CHONGQING LINGLONG ELECTRONIC CO., LTD.
				外形图 outline drawing
				版本 Revision
				未注线性公差 TOL.
				未注线性公差未注角度公差 Angles
				比例 Scale
				单位 Unit
				存货编码 Stock code
				30301000012
				±0.2
				±0.3°
				6:1
				mm
				A. 1

	产品规格书/specification	No	LL-3-J-19000
		版本Revision	A. 2
	存货编码/Stock code.: 30301000012	页码Page	11 of 11
		日期Date	2018-7-11

11. 使用注意事项说明/Matters to be paid attention to when using motor

11-1 电机在运输过程中应小心轻放，避免碰撞敲击引起的电机机身和性能受损。

Please place the motors careflly in transportation to avoid any damage to the motor body or its electric function because of collision.

11-2 电机不能在高温、高湿、带有腐蚀性气体的环境中贮存和使用，否则有可能导致电机的性能下降。

Please don't leave and use the motors in the environment of high temperature,high humidity and corrosion gas,or it would cause the function to fall down.

11-3 不能长时间用外力锁死振动轮，以免烧坏线圈，电机不能工作。

Please don't lock up the vibrating wheel,or the coil would be burned up and the motors can't operate.

11-4 避免接触或靠近强磁性物体，否则有可能导致电机性能下降。

Please prevent from magnetic objects,or it may cause the function fall down.

11-5 请在6个月内使用，在使用时和打开包装时，请避免水气凝结。

Please use the motors within six months and prevent them from coagulation of moisture when open the pockage and use them.

11-6 回流焊温度：

Reflow Temperature :

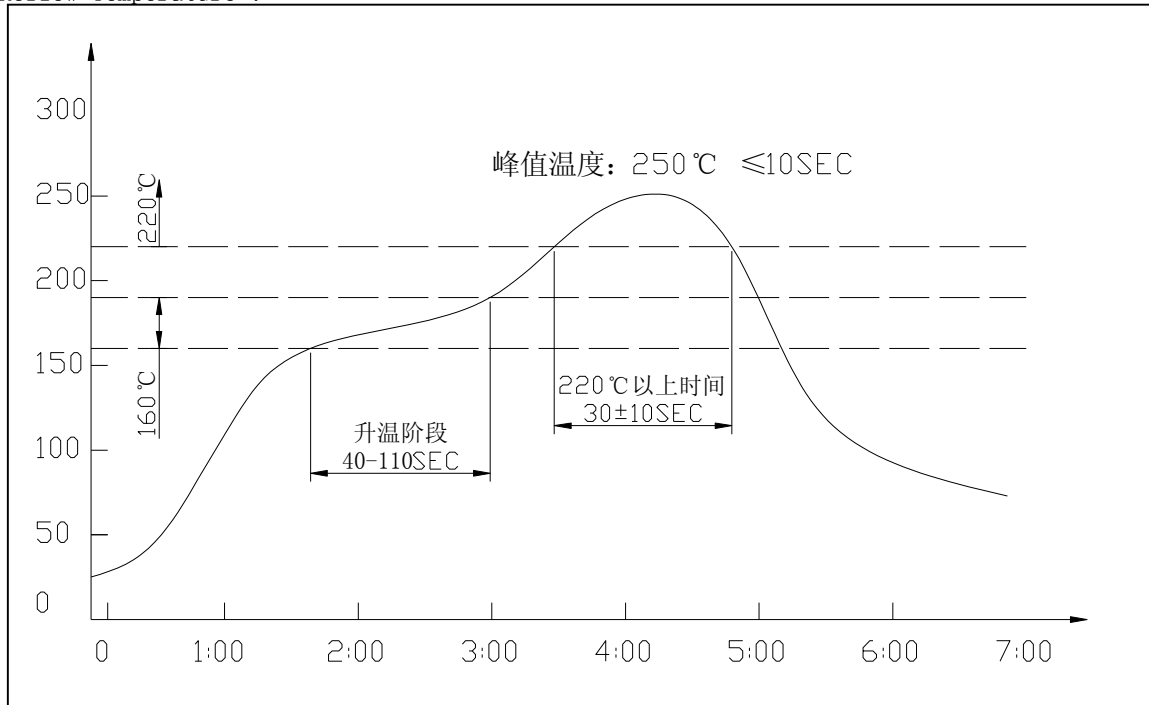

X-ON Electronics

Largest Supplier of Electrical and Electronic Components

Click to view similar products for [AC, DC & Servo Motors](#) category:

Click to view products by [LNLON](#) manufacturer:

Other Similar products are found below :

[79207644](#) [808550Y00049Z](#) [82520405](#) [82802504](#) [R88M-G10030H-S2](#) [R88MK10030H](#) [HG16-240-AB-00](#) [M4E068-EC03-01](#) [79265119](#)
[80510503](#) [805470A40040MY](#) [805470B40020MY](#) [80627003](#) [82714023](#) [82800003](#) [82830009](#) [82810017](#) [89830012](#) [82840003](#) [82840004](#)
[82869011](#) [82524021](#) [82862202](#) [82869006](#) [82861013](#) [80803009](#) [80547015](#) [82862205](#) [R88M-K40030T-B](#) [80527006](#) [82304012](#) [82330514](#)
[81021118](#) [82524004](#) [82867009](#) [82662515](#) [82524008](#) [82524006](#) [82344760](#) [82344727](#) [82344659](#) [82340184](#) [82334768](#) [82304032](#) [82304017](#)
[81033031](#) [81033009](#) [81021072](#) [80817014](#) [80813005](#)