

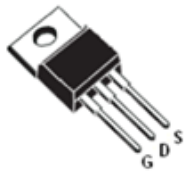
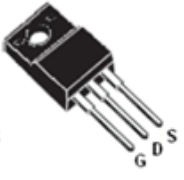
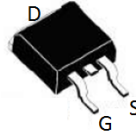
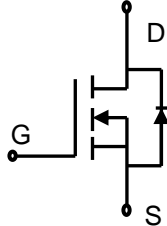

Lonten N-channel 100V, 80A, 18mΩ Power MOSFET

<p>Description These N-Channel enhancement mode power field effect transistors are using trench DMOS technology. This advanced technology has been especially tailored to minimize on-state resistance, provide superior switching performance, and with stand high energy pulse in the avalanche and commutation mode. These devices are well suited for high efficiency fast switching applications.</p> <p>Features</p> <ul style="list-style-type: none"> ◆ 100V,80A,$R_{DS(on).max}=18m\Omega@V_{GS}=10V$ ◆ Improved dv/dt capability ◆ Fast switching ◆ 100% EAS Guaranteed ◆ Green device available <p>Applications</p> <ul style="list-style-type: none"> ◆ Motor Drives ◆ UPS ◆ DC-DC Converter 	<p>Product Summary</p> <table style="width: 100%; border: none;"> <tr> <td style="padding: 2px;">V_{DSS}</td> <td style="padding: 2px;">100V</td> </tr> <tr> <td style="padding: 2px;">$R_{DS(on).max}@V_{GS}=10V$</td> <td style="padding: 2px;">18mΩ</td> </tr> <tr> <td style="padding: 2px;">I_D</td> <td style="padding: 2px;">80A</td> </tr> </table> <p>Pin Configuration</p> <div style="display: flex; justify-content: space-around; align-items: center;"> <div style="text-align: center;">  TO-220 </div> <div style="text-align: center;">  TO-220MF </div> </div> <div style="display: flex; justify-content: space-around; align-items: center; margin-top: 10px;"> <div style="text-align: center;">  TO-263 </div> <div style="text-align: center;">  </div> </div> <p style="text-align: center; margin-top: 20px;">N-Channel MOSFET </p>	V_{DSS}	100V	$R_{DS(on).max}@V_{GS}=10V$	18mΩ	I_D	80A
V_{DSS}	100V						
$R_{DS(on).max}@V_{GS}=10V$	18mΩ						
I_D	80A						

Absolute Maximum Ratings $T_C = 25^\circ\text{C}$ unless otherwise noted

Parameter	Symbol	Value	Unit
Drain-Source Voltage	V_{DSS}	100	V
Continuous drain current ($T_C = 25^\circ\text{C}$) ¹⁾	I_D	80	A
Continuous drain current ($T_C = 100^\circ\text{C}$) ¹⁾		57	A
Pulsed drain current ²⁾	I_{DM}	320	A
Gate-Source voltage	V_{GSS}	± 20	V
Avalanche energy ³⁾	E_{AS}	240	mJ
Power Dissipation ($T_C = 25^\circ\text{C}$) TO-220/TO-263	P_D	147	W
Power Dissipation ($T_C = 25^\circ\text{C}$) TO-220MF		49	W
Storage Temperature Range	T_{STG}	-55 to +150	$^\circ\text{C}$
Operating Junction Temperature Range	T_J	-55 to +150	$^\circ\text{C}$

Thermal Characteristics

Parameter	Symbol	Value	Unit
Thermal Resistance, Junction-to-Case TO-220/TO-263	$R_{\theta JC}$	0.85	$^\circ\text{C/W}$
Thermal Resistance, Junction-to-Case TO-220MF		2.55	$^\circ\text{C/W}$
Thermal Resistance, Junction-to-Ambient TO-220/TO-263	$R_{\theta JA}$	62	$^\circ\text{C/W}$
Thermal Resistance, Junction-to-Ambient TO-220MF		80	$^\circ\text{C/W}$

Package Marking and Ordering Information

Device	Device Package	Marking
LNC10R180	TO-220	LNC10R180
LND10R180	TO-220MF	LND10R180
LNE10R180	TO-263	LNE10R180

Electrical Characteristics
 $T_J = 25^\circ\text{C}$ unless otherwise noted

Parameter	Symbol	Test Condition	Min.	Typ.	Max.	Unit
Static characteristics						
Drain-source breakdown voltage	BV_{DSS}	$V_{GS}=0\text{ V}, I_D=250\mu\text{A}$	100	---	---	V
Gate threshold voltage	$V_{GS(th)}$	$V_{DS}=V_{GS}, I_D=250\mu\text{A}$	1.0	---	3.0	V
Drain-source leakage current	I_{DSS}	$V_{DS}=100\text{V}, V_{GS}=0\text{V}, T_J = 25^\circ\text{C}$	---	---	1	μA
		$V_{DS}=80\text{V}, V_{GS}=0\text{V}, T_J = 125^\circ\text{C}$	---	---	10	μA
Gate leakage current, Forward	I_{GSSF}	$V_{GS}=20\text{ V}, V_{DS}=0\text{ V}$	---	---	100	nA
Gate leakage current, Reverse	I_{GSSR}	$V_{GS}=-20\text{ V}, V_{DS}=0\text{ V}$	---	---	-100	nA
Drain-source on-state resistance	$R_{DS(on)}$	$V_{GS}=10\text{ V}, I_D=16\text{ A}$	---	13.5	18	m Ω
		$V_{GS}=4.5\text{ V}, I_D=8\text{ A}$	---	16	23	m Ω
Forward transconductance	g_{fs}	$V_{DS} = 10\text{V}, I_D=20\text{A}$	---	85	---	S
Dynamic characteristics						
Input capacitance	C_{iss}	$V_{DS} = 50\text{ V}, V_{GS} = 0\text{ V},$ $F = 1\text{MHz}$	---	6102	---	pF
Output capacitance	C_{oss}		---	215	---	
Reverse transfer capacitance	C_{rss}		---	159	---	
Turn-on delay time	$t_{d(on)}$	$V_{DD} = 50\text{V}, V_{GS}=10\text{V}, I_D = 20\text{A}$	---	20	---	ns
Rise time	t_r		---	56	---	
Turn-off delay time	$t_{d(off)}$		---	75	---	
Fall time	t_f		---	36	---	
Gate resistance	R_g	$V_{GS}=0\text{V}, V_{DS}=0\text{V}, F=1\text{MHz}$	---	1.5	---	Ω
Gate charge characteristics						
Gate to source charge	Q_{gs}	$V_{DS}=50\text{ V}, I_D=20\text{A},$ $V_{GS}= 10\text{ V}$	---	18	---	nC
Gate to drain charge	Q_{gd}		---	32	---	
Gate charge tota	Q_g		---	127	---	
Drain-Source diode characteristics and Maximum Ratings						
Diode Forward Voltage ⁴⁾	V_{SD}	$V_{GS}=0\text{V}, I_S=50\text{A}, T_J=25^\circ\text{C}$	---	0.85	1.3	V
Reverse Recovery Time	t_{rr}	$I_S=20\text{A}, di/dt=60\text{A}/\mu\text{s}, T_J=25^\circ\text{C}$	---	160	---	ns
Reverse Recovery Charge	Q_{rr}		---	136	---	nC

Notes:

- 1: The maximum junction current rating is package limited.
- 2: Repetitive Rating: Pulse width limited by maximum junction temperature.
- 3: $V_{DD}=50\text{V}, V_{GS}=10\text{V}, L=0.5\text{mH}, I_{AS}=31\text{A}, R_G=25\Omega,$ Starting $T_J=25^\circ\text{C}$.
- 4: Pulse Test: Pulse Width $\leq 300\ \mu\text{s}$, Duty Cycle $\leq 2\%$.

Electrical Characteristics Diagrams

Figure 1. Typ. Output Characteristics

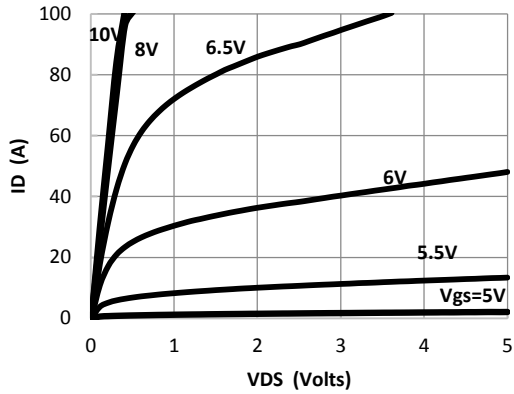

Figure 2. Transfer Characteristics

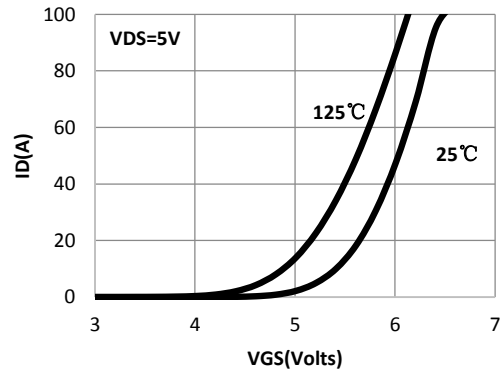

Figure 3. Capacitance Characteristics

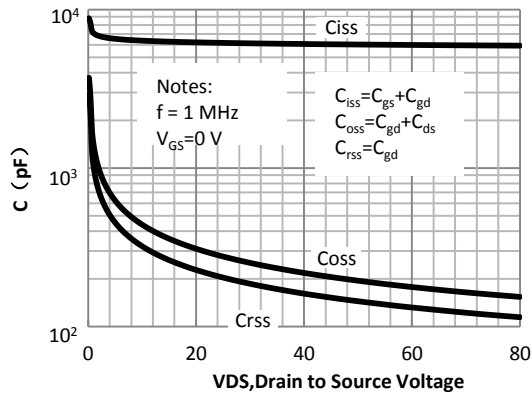

Figure 4. Gate Charge Waveform

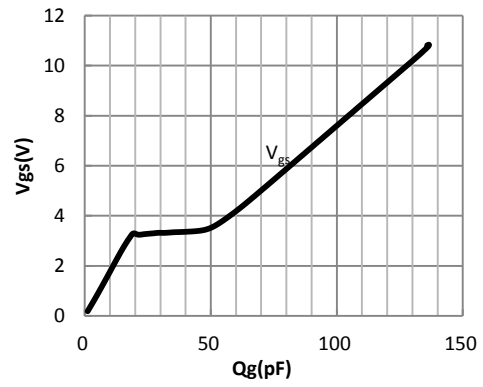

Figure 5. Body-Diode Characteristics

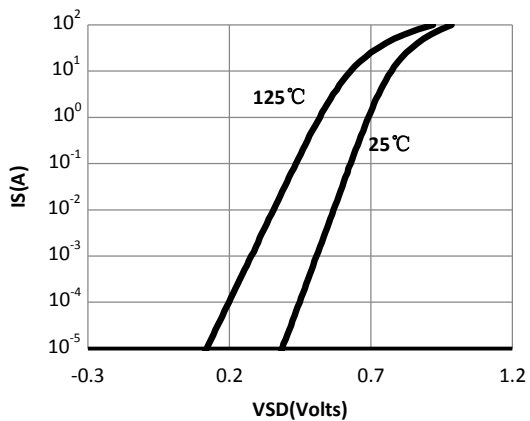

Figure 6. Normalized Maximum Transient Thermal Impedance (RthJC)

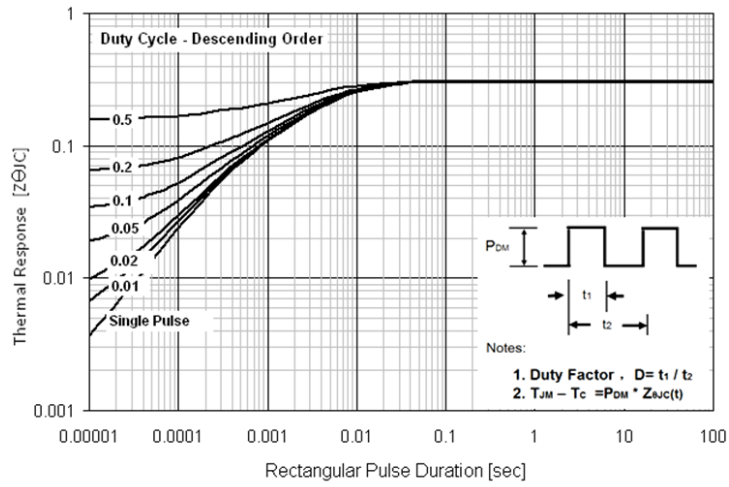
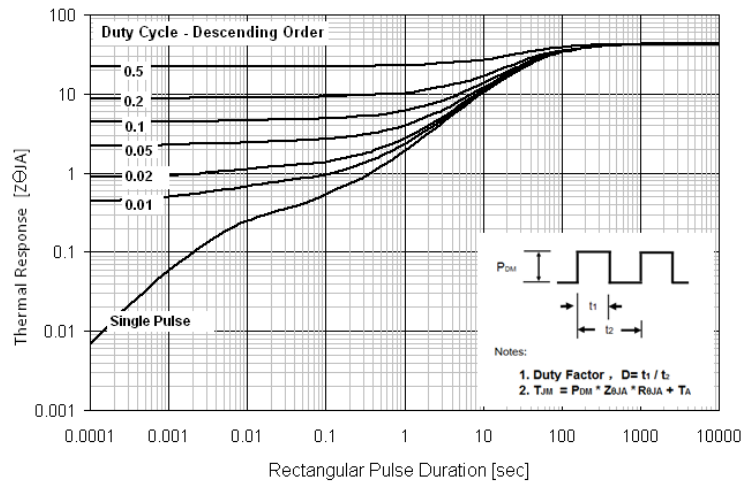

Figure 7. Normalized Maximum Transient Thermal Impedance (RthJA)



Test Circuit & Waveform

Figure 8. Gate Charge Test Circuit & Waveform

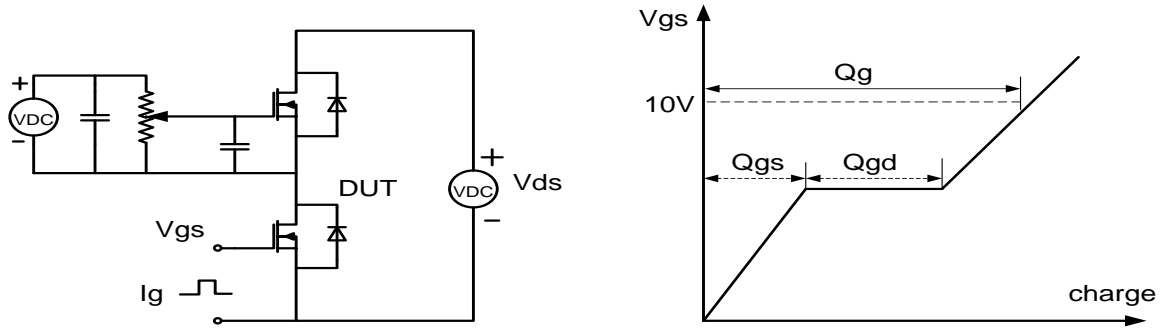

Figure 9. Resistive Switching Test Circuit & Waveforms

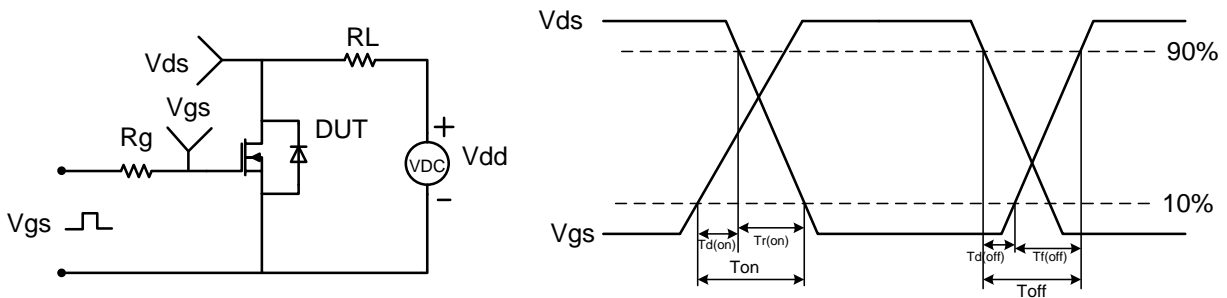

Figure 10. Unclamped Inductive Switching (UIS) Test Circuit & Waveform

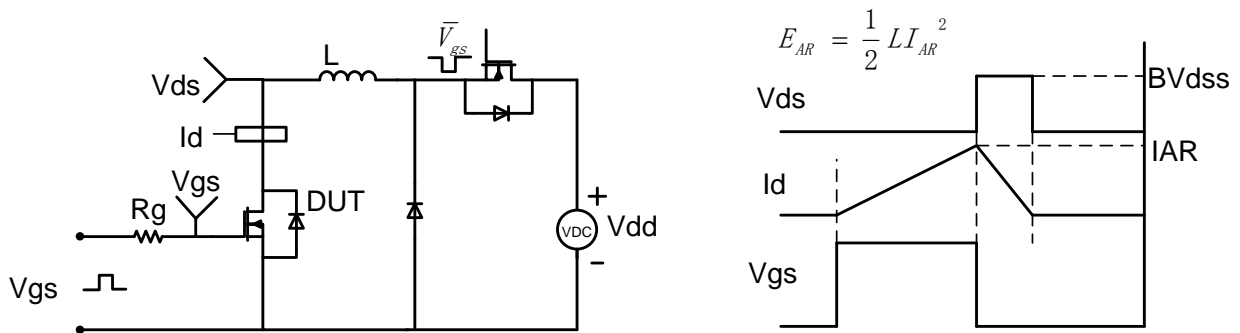
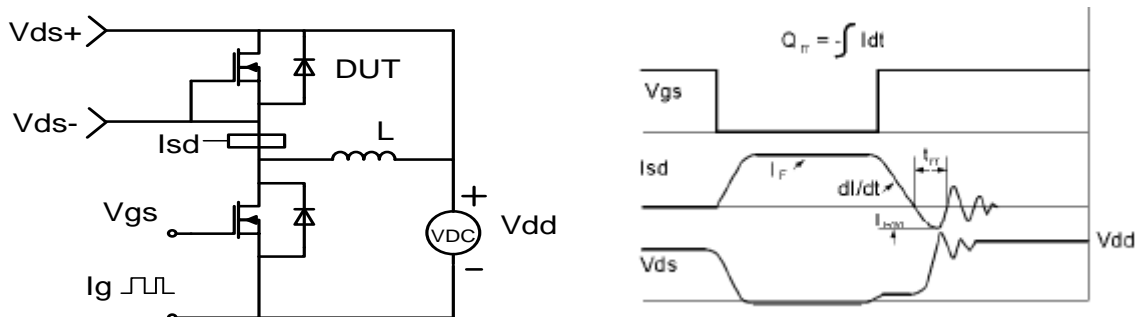
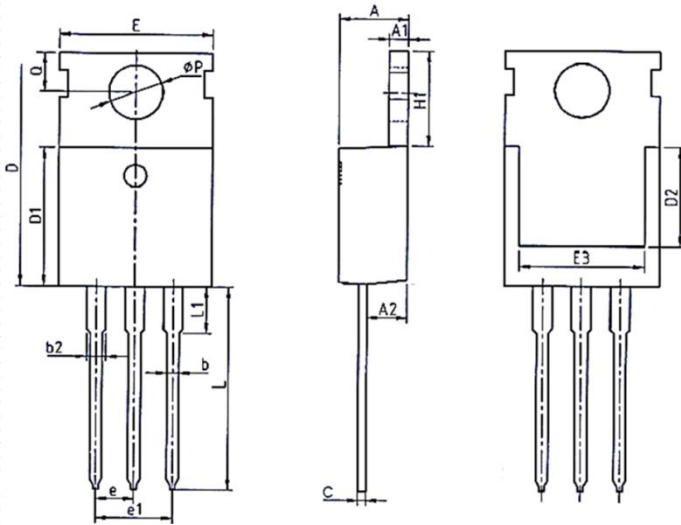

Figure 11. Diode Recovery Circuit & Waveform



Mechanical Dimensions for TO-220



COMMON DIMENSIONS						
SYMBOL	MM			INCH		
	MIN	NOM	MAX	MIN	NOM	MAX
A	4.37	4.57	4.70	0.172	0.180	0.185
A1	1.25	1.30	1.40	0.049	0.051	0.055
A2	2.20	2.40	2.60	0.087	0.094	0.102
b	0.70	0.80	0.95	0.028	0.031	0.037
b2	1.17	1.27	1.47	0.046	0.050	0.058
c	0.45	0.50	0.60	0.018	0.020	0.024
D	15.10	15.60	16.10	0.594	0.614	0.634
D1	8.80	9.10	9.40	0.346	0.358	0.370
D2	5.50	-	-	0.217	-	-
E	9.70	10.00	10.30	0.382	0.394	0.406
E3	7.00	-	-	0.276	-	-
e	2.54BCS			0.1BSC		
e1	5.08BCS			0.2REF		
H1	6.25	6.50	6.85	0.246	0.256	0.270
L	12.75	13.50	13.80	0.502	0.531	0.543
L1	-	3.10	3.40	-	0.122	0.134
ØP	3.40	3.60	3.80	0.134	0.142	0.150
Q	2.60	2.80	3.00	0.102	0.110	0.118

TO-220 Part Marking Information

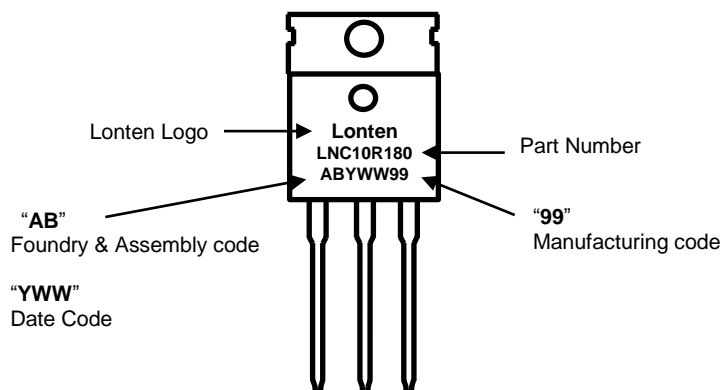

Mechanical Dimensions for TO-220MF

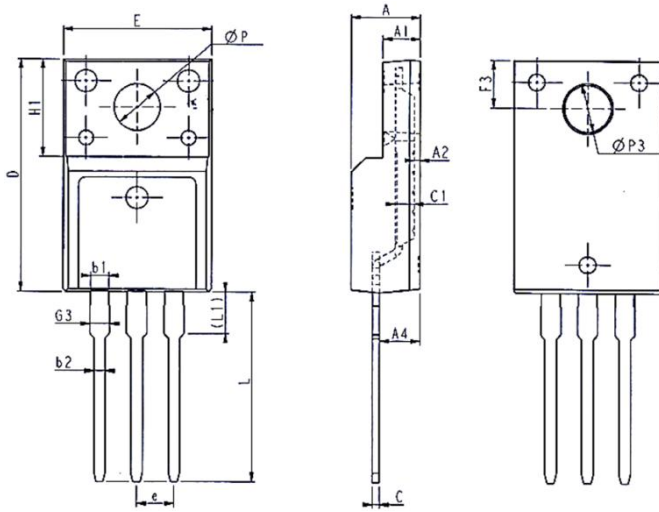

SYMBOL	COMMON DIMENSIONS					
	MM			INCH		
	MIN	NOM	MAX	MIN	NOM	MAX
E	9.96	10.16	10.36	0.392	0.400	0.408
A	4.50	4.70	4.90	0.177	0.185	0.193
A1	2.34	2.54	2.74	0.092	0.100	0.108
A2	0.30	0.45	0.60	0.012	0.018	0.024
A4	2.56	2.76	2.96	0.101	0.109	0.117
c	0.40	0.50	0.65	0.016	0.020	0.026
c1	1.20	1.30	1.35	0.047	0.051	0.053
D	15.57	15.87	16.17	0.613	0.625	0.637
H1	6.70REF			0.264REF		
e	2.54BSC			0.1BSC		
L	12.68	12.98	13.28	0.499	0.511	0.523
L1	2.88	3.03	3.18	0.113	0.119	0.125
ØP	3.03	3.18	3.38	0.119	0.125	0.133
ØP3	3.15	3.45	3.65	0.124	0.136	0.144
F3	3.15	3.30	3.45	0.124	0.130	0.136
G3	1.25	1.35	1.55	0.049	0.053	0.061
b1	1.18	1.28	1.43	0.046	0.050	0.056
b2	0.70	0.80	0.95	0.028	0.031	0.037

TO-220MF Part Marking Information

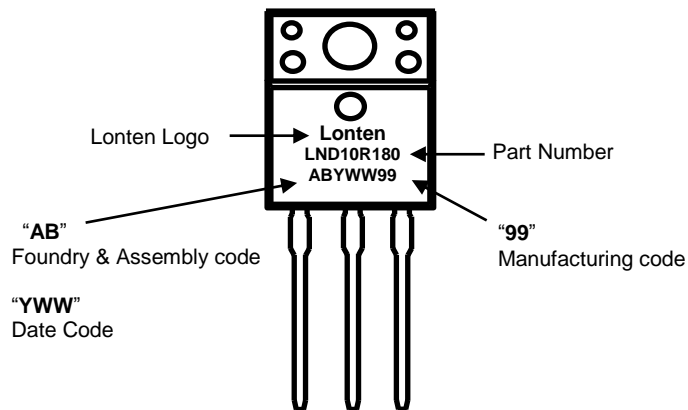

TO-263 PACKAGE INFORMATION

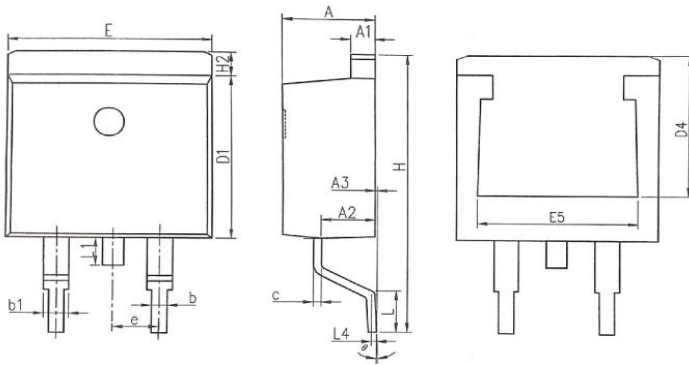

COMMON DIMENSIONS						
SYMBOL	MM			INCH		
	MIN	NOM	MAX	MIN	NOM	MAX
A	4.37	4.57	4.77	0.172	0.180	0.188
A1	1.22	1.27	1.42	0.048	0.050	0.056
A2	2.49	2.69	2.89	0.098	0.106	0.114
A3	0.00	0.13	0.25	0.000	0.005	0.010
b	0.70	0.81	0.96	0.028	0.032	0.038
b1	1.17	1.27	1.47	0.046	0.050	0.058
c	0.30	0.38	0.53	0.012	0.015	0.021
D1	8.50	8.70	8.90	0.335	0.343	0.350
D4	6.60	—	—	0.260	—	—
E	9.86	10.16	10.36	0.388	0.400	0.408
E5	7.06	—	—	0.278	—	—
e	2.54 BSC			0.100 BSC		
H	14.70	15.10	15.50	0.579	0.594	0.610
H2	1.07	1.27	1.47	0.042	0.050	0.058
L	2.00	2.30	2.60	0.079	0.091	0.102
L1	1.40	1.55	1.70	0.055	0.061	0.067
L4	0.25 BSC			0.010 BSC		
θ	0°	5°	9°	0°	5°	9°

TO-263 Part Marking Information

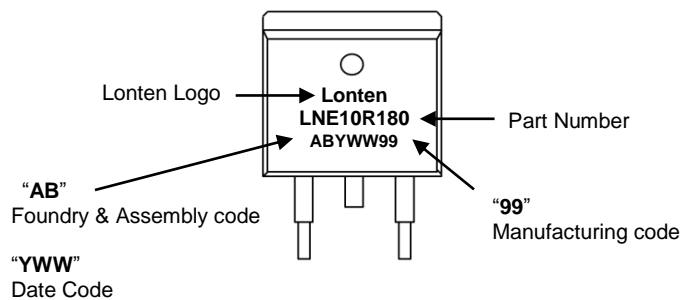

Disclaimer

The content specified herein is for the purpose of introducing LONTEN's products (hereinafter "Products"). The information given in this document shall in no event be regarded as a guarantee of conditions or characteristics. Examples of application circuits, circuit constants and any other information contained herein illustrate the standard usage and operations of the Products. The peripheral conditions must be taken into account when designing circuits for mass production.

LONTEN does not assume any liability for infringement of patents, copyrights, or other intellectual property rights of third parties by or arising from the use of the Products or technical information described in this document.

The Products are not designed or manufactured to be used with any equipment, device or system which requires an extremely high level of reliability the failure or malfunction of which may result in a direct threat to human life or create a risk of human injury (such as a medical instrument, transportation equipment, aerospace machinery, nuclear-reactor controller, fuel-controller or other safety device). LONTEN shall bear no responsibility in any way for use of any of the Products for the above special purposes.

Although LONTEN endeavors to improve the quality and reliability of its products, semiconductor products have specific characteristics such as the occurrence of failure at a certain rate and malfunctions under certain use conditions. Please be sure to implement safety measures to guard them against the possibility of physical injury, and injury or damage caused by fire in the event of the failure of a LONTEN product.

The content specified herein is subject to change for improvement without notice. When using a LONTEN product, be sure to obtain the latest specifications.

X-ON Electronics

Largest Supplier of Electrical and Electronic Components

Click to view similar products for [MOSFET](#) category:

Click to view products by [LONTEN](#) manufacturer:

Other Similar products are found below :

[614233C](#) [648584F](#) [MCH3443-TL-E](#) [MCH6422-TL-E](#) [FDPF9N50NZ](#) [FW216A-TL-2W](#) [FW231A-TL-E](#) [APT5010JVR](#) [NTNS3A92PZT5G](#)
[IRF100S201](#) [JANTX2N5237](#) [2SK2464-TL-E](#) [2SK3818-DL-E](#) [FCA20N60_F109](#) [FDZ595PZ](#) [STD6600NT4G](#) [FSS804-TL-E](#) [2SJ277-DL-E](#)
[2SK1691-DL-E](#) [2SK2545\(Q,T\)](#) [D2294UK](#) [405094E](#) [423220D](#) [MCH6646-TL-E](#) [TPCC8103,L1Q\(CM](#) [367-8430-0972-503](#) [VN1206L](#)
[424134F](#) [026935X](#) [051075F](#) [SBVS138LT1G](#) [614234A](#) [715780A](#) [NTNS3166NZT5G](#) [751625C](#) [873612G](#) [IRF7380TRHR](#)
[IPS70R2K0CEAKMA1](#) [RJK60S3DPP-E0#T2](#) [RJK60S5DPK-M0#T0](#) [APT5010JVFR](#) [APT12031JFLL](#) [APT12040JVR](#) [DMN3404LQ-7](#)
[NTE6400](#) [JANTX2N6796U](#) [JANTX2N6784U](#) [JANTXV2N5416U4](#) [SQM110N05-06L-GE3](#) [SIHF35N60E-GE3](#)