

Lonten N-channel 600V, 47A, 0.07Ω LonFET™ Power MOSFET

| | | | | | | | | | |
|--|--|----------------------|------|------------------|-------|----------|------|-------------|------|
| <p>Description LonFET™ Power MOSFET is fabricated using advanced super junction technology. The resulting device has extremely low on resistance, making it especially suitable for applications which require superior power density and outstanding efficiency.</p> <p>Features</p> <ul style="list-style-type: none"> ◆ Ultra low $R_{DS(on)}$ ◆ Ultra low gate charge (typ. $Q_g = 68\text{nC}$) ◆ 100% UIS tested ◆ RoHS compliant <p>Applications</p> <ul style="list-style-type: none"> ◆ Power factor correction (PFC). ◆ Switched mode power supplies (SMPS). ◆ Uninterruptible power supply (UPS). | <p>Product Summary</p> <table style="width: 100%; border: none;"> <tr> <td style="padding: 2px;">$V_{DS} @ T_{j,max}$</td> <td style="padding: 2px;">650V</td> </tr> <tr> <td style="padding: 2px;">$R_{DS(on),max}$</td> <td style="padding: 2px;">0.07Ω</td> </tr> <tr> <td style="padding: 2px;">I_{DM}</td> <td style="padding: 2px;">141A</td> </tr> <tr> <td style="padding: 2px;">$Q_{g,typ}$</td> <td style="padding: 2px;">68nC</td> </tr> </table> <div style="text-align: center; margin-top: 10px;"> </div> <p style="text-align: center; margin-top: 10px;">N-Channel MOSFET</p> | $V_{DS} @ T_{j,max}$ | 650V | $R_{DS(on),max}$ | 0.07Ω | I_{DM} | 141A | $Q_{g,typ}$ | 68nC |
| $V_{DS} @ T_{j,max}$ | 650V | | | | | | | | |
| $R_{DS(on),max}$ | 0.07Ω | | | | | | | | |
| I_{DM} | 141A | | | | | | | | |
| $Q_{g,typ}$ | 68nC | | | | | | | | |

Absolute Maximum Ratings

| Parameter | Symbol | Value | Unit |
|--|----------------|-------------|---------------------|
| Drain-Source Voltage | V_{DSS} | 600 | V |
| Continuous drain current ($T_C = 25^\circ\text{C}$) | I_D | 47 | A |
| ($T_C = 100^\circ\text{C}$) | | 30 | A |
| Pulsed drain current ¹⁾ | I_{DM} | 141 | A |
| Gate-Source voltage | V_{GSS} | ± 30 | V |
| Avalanche energy, single pulse ²⁾ | E_{AS} | 1055 | mJ |
| Power Dissipation TO-247 ($T_C = 25^\circ\text{C}$) | P_D | 280 | W |
| - Derate above 25°C | | 2.24 | W/ $^\circ\text{C}$ |
| Power Dissipation TO-220MF ($T_C = 25^\circ\text{C}$) | P_D | 37 | W |
| - Derate above 25°C | | 0.30 | W/ $^\circ\text{C}$ |
| Operating and Storage Temperature Range | T_J, T_{STG} | -55 to +150 | $^\circ\text{C}$ |
| Continuous diode forward current | I_S | 47 | A |
| Diode pulse current | $I_{S,pulse}$ | 141 | A |

Thermal Characteristics TO-247

| Parameter | Symbol | Value | Unit |
|---|-----------------|-------|---------------|
| Thermal Resistance, Junction-to-Case | $R_{\theta JC}$ | 0.45 | $^{\circ}C/W$ |
| Thermal Resistance, Junction-to-Ambient | $R_{\theta JA}$ | 62 | $^{\circ}C/W$ |
| Soldering temperature, wavesoldering only allowed at leads. (1.6mm from case for 10s) | T_{sold} | 260 | $^{\circ}C$ |

Thermal Characteristics TO-220MF

| Parameter | Symbol | Value | Unit |
|---|-----------------|-------|---------------|
| Thermal Resistance, Junction-to-Case | $R_{\theta JC}$ | 3.33 | $^{\circ}C/W$ |
| Thermal Resistance, Junction-to-Ambient | $R_{\theta JA}$ | 77 | $^{\circ}C/W$ |
| Soldering temperature, wavesoldering only allowed at leads. (1.6mm from case for 10s) | T_{sold} | 260 | $^{\circ}C$ |

Package Marking and Ordering Information

| Device | Device Package | Marking | Units/Tube | Units/Reel |
|-------------|----------------|-------------|------------|------------|
| LSB60R070HT | TO-247 | LSB60R070HT | 30 | |
| LSD60R070HT | TO-220MF | LSD60R070HT | 50 | |

Electrical Characteristics $T_c = 25^{\circ}C$ unless otherwise noted

| Parameter | Symbol | Test Condition | Min. | Typ. | Max. | Unit |
|------------------------------------|--------------|--|------|-------|-------|----------|
| Static characteristics | | | | | | |
| Drain-source breakdown voltage | BV_{DSS} | $V_{GS}=0V, I_D=0.25mA$ | 600 | - | - | V |
| Gate threshold voltage | $V_{GS(th)}$ | $V_{DS}=V_{GS}, I_D=0.25mA$ | 2.5 | 3.5 | 4.5 | V |
| Drain cut-off current | I_{DSS} | $V_{DS}=600V, V_{GS}=0V,$ $T_j = 25^{\circ}C$ $T_j = 125^{\circ}C$ | - | - | 1 | μA |
| | | | - | 10 | - | |
| Gate leakage current, Forward | I_{GSSF} | $V_{GS}=30V, V_{DS}=0V$ | - | - | 100 | nA |
| Gate leakage current, Reverse | I_{GSSR} | $V_{GS}=-30V, V_{DS}=0V$ | - | - | -100 | nA |
| Drain-source on-state resistance | $R_{DS(on)}$ | $V_{GS}=10V, I_D=23.5A$ $T_j = 25^{\circ}C$ $T_j = 150^{\circ}C$ | - | - | - | Ω |
| | | | - | 0.060 | 0.070 | |
| | | | - | 0.16 | - | |
| Dynamic characteristics | | | | | | |
| Input capacitance | C_{iss} | $V_{DS} = 100V, V_{GS} = 0V,$ $f = 250kHz$ | - | 4070 | - | pF |
| Output capacitance | C_{oss} | | - | 158 | - | |
| Reverse transfer capacitance | C_{rss} | | - | 2.5 | - | |
| Turn-on delay time | $t_{d(on)}$ | $V_{DD} = 400V, I_D = 23.5A$ $R_G = 10\Omega, V_{GS}=10V$ | - | 32.3 | - | ns |
| Rise time | t_r | | - | 66.2 | - | |
| Turn-off delay time | $t_{d(off)}$ | | - | 200 | - | |
| Fall time | t_f | | - | 11.7 | - | |
| Gate charge characteristics | | | | | | |
| Gate to source charge | Q_{gs} | $V_{DD}=480V, I_D=23.5A,$ | - | 19.1 | - | |

| | | | | | | |
|--------------------------------------|---------------|---|---|------|---|---------|
| Gate to drain charge | Q_{gd} | $V_{GS}=0$ to 10 V | - | 19.2 | - | nC |
| Gate charge total | Q_g | | - | 68 | - | |
| Gate plateau voltage | $V_{plateau}$ | | - | 5.0 | - | V |
| Reverse diode characteristics | | | | | | |
| Diode forward voltage | V_{SD} | $V_{GS}=0$ V, $I_F=23.5$ A | - | 1.0 | - | V |
| Reverse recovery time | t_{rr} | $V_R=50$ V, $I_F=20$ A, $di_F/dt=100$ A/ μ s | - | 415 | - | ns |
| Reverse recovery charge | Q_{rr} | | - | 4.9 | - | μ C |
| Peak reverse recovery current | I_{rrm} | | - | 23.8 | - | A |

Notes:

- Limited by maximum junction temperature, maximum duty cycle is 0.75.
- $I_{AS} = 7.5$ A, $V_{DD} = 60$ V, Starting $T_J = 25^\circ$ C.

Electrical Characteristics Diagrams

Figure 1. On-Region Characteristics

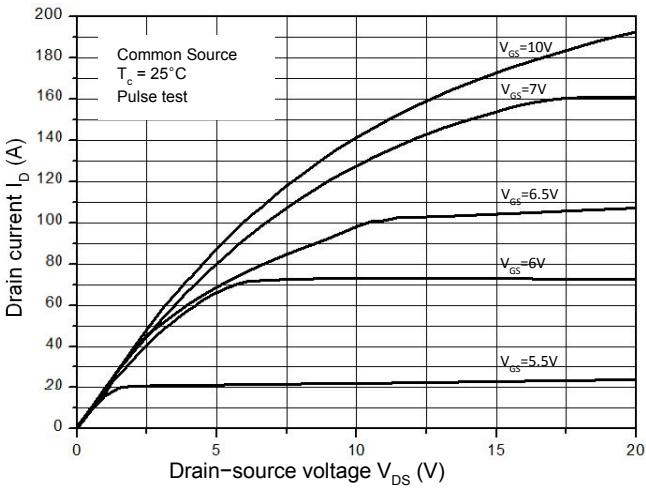

Figure 2. Transfer Characteristics

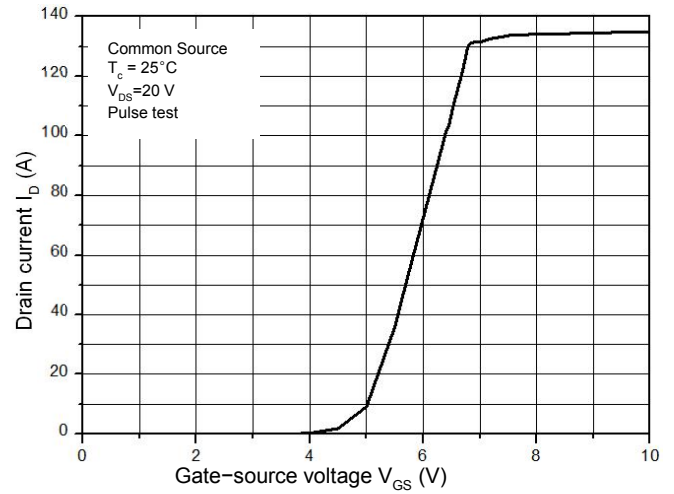

Figure 3. On-Resistance Variation vs. Drain Current

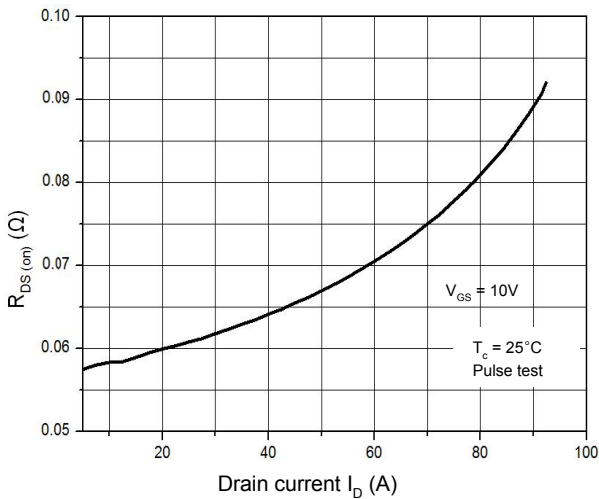

Figure 4. Threshold Voltage vs. Temperature

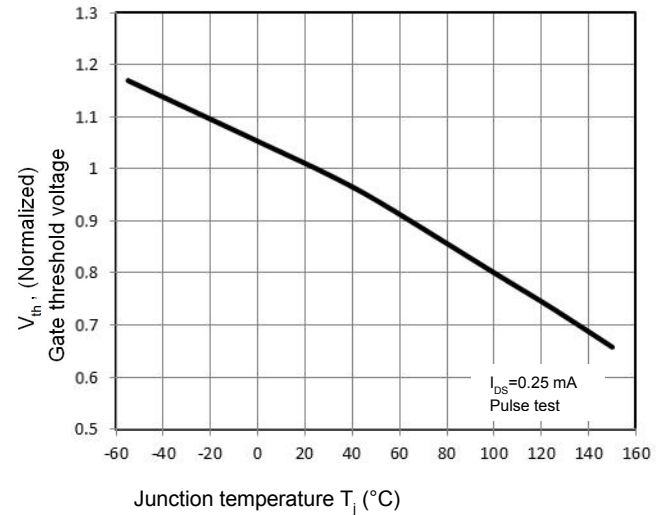

Figure 5. Breakdown Voltage vs. Temperature

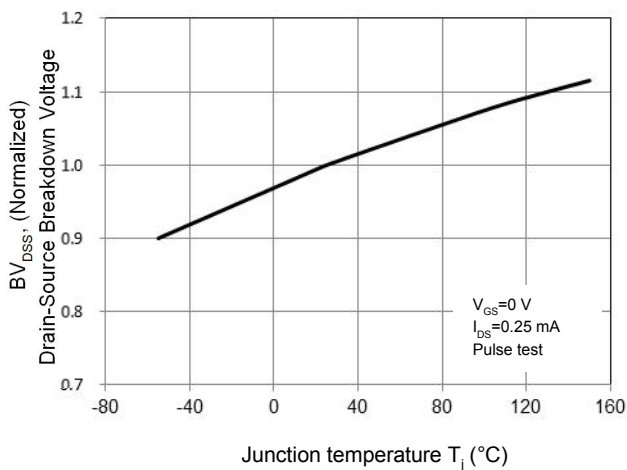

Figure 6. On-Resistance vs. Temperature

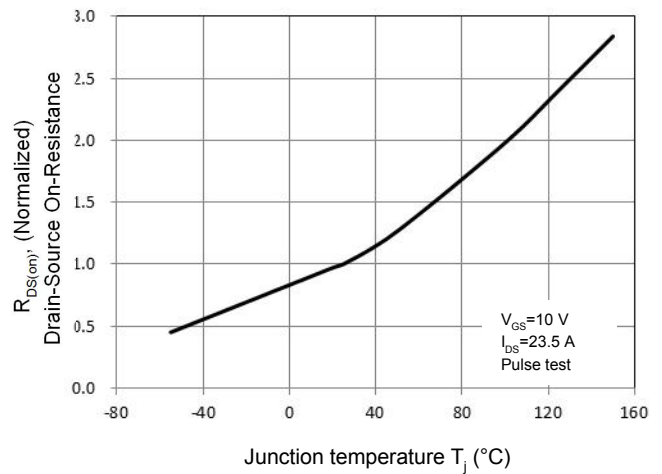

Figure 7. Capacitance Characteristics

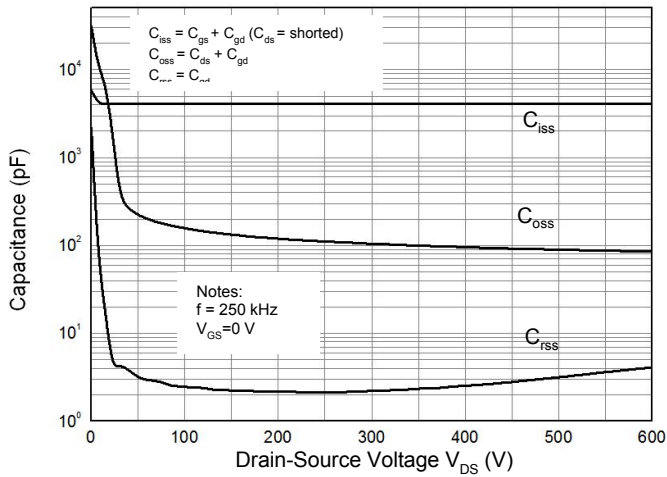

Figure 8. Gate Charge Characterist

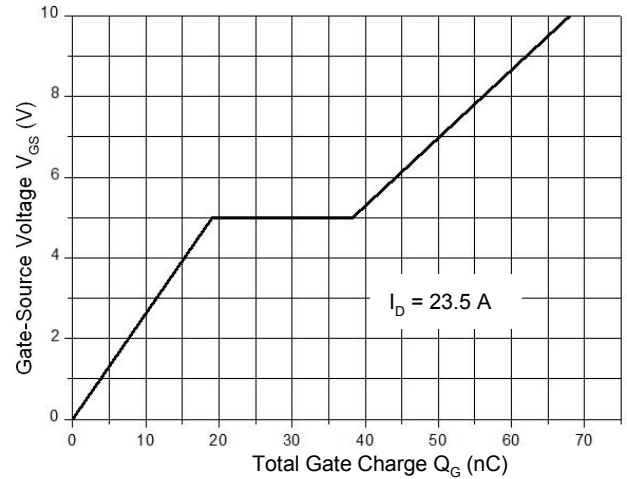

Figure 9.1 Maximum Safe Operating Area
TO-247

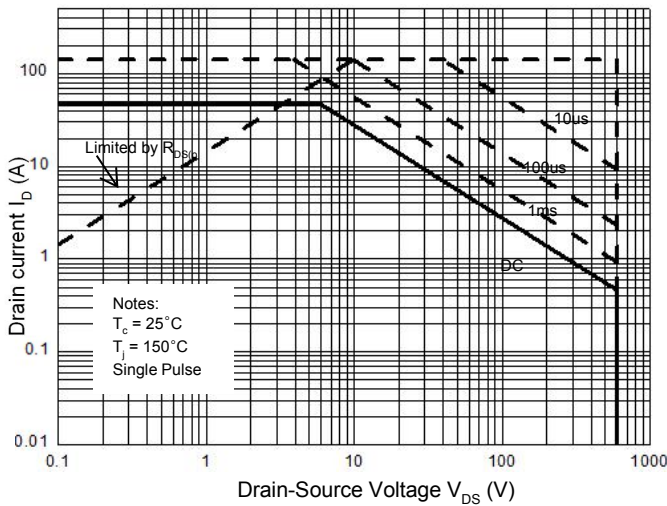

Figure 9.2 Maximum Safe Operating Area
TO-220MF

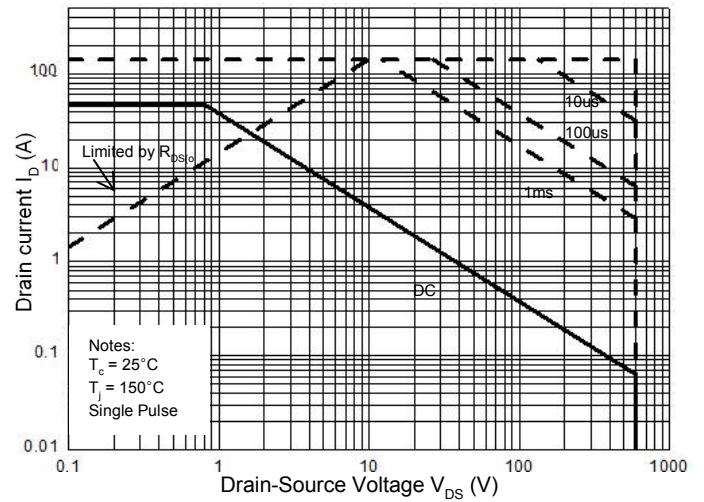

Figure 10.1 Power Dissipation vs. Temperature
TO-247

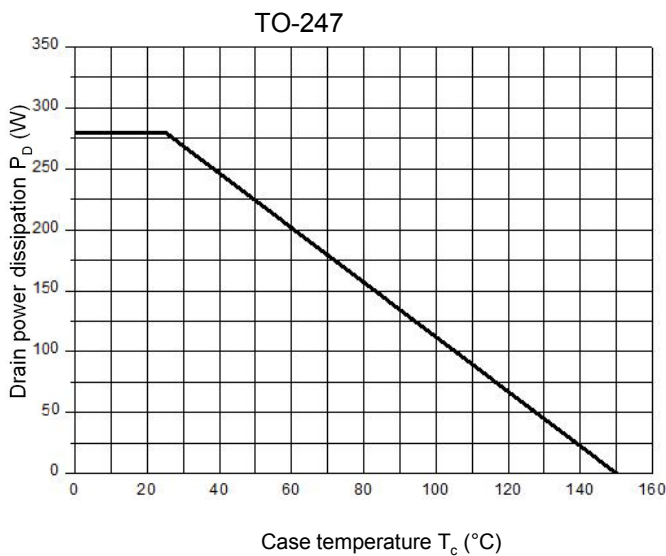
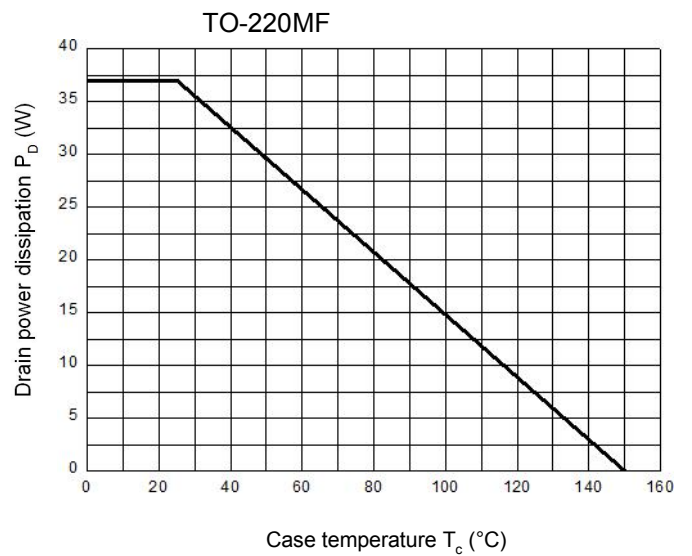
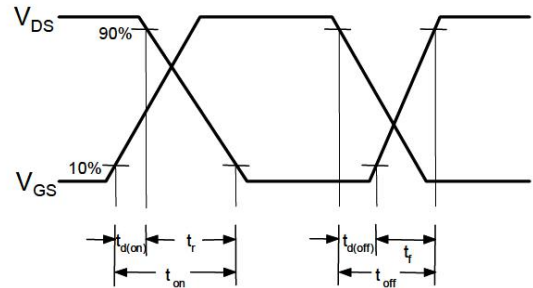
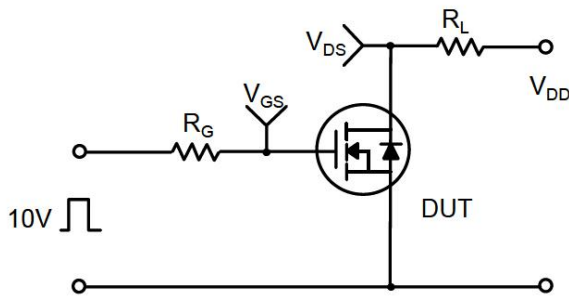
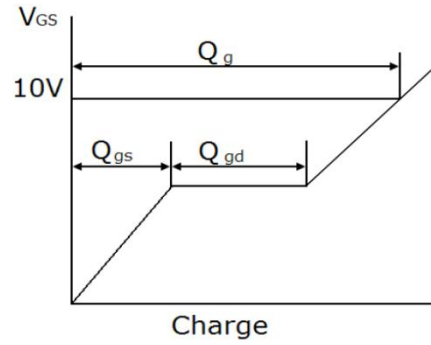
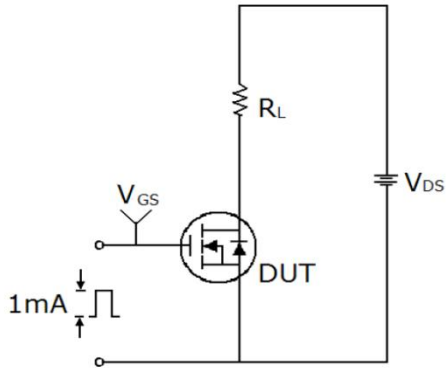

Figure 10.2 Power Dissipation vs. Temperature
TO-220MF



Gate Charge Test Circuit & Waveform



Unclamped Inductive Switching Test Circuit & Waveforms

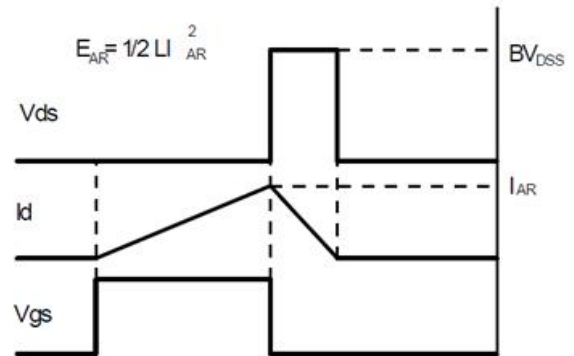
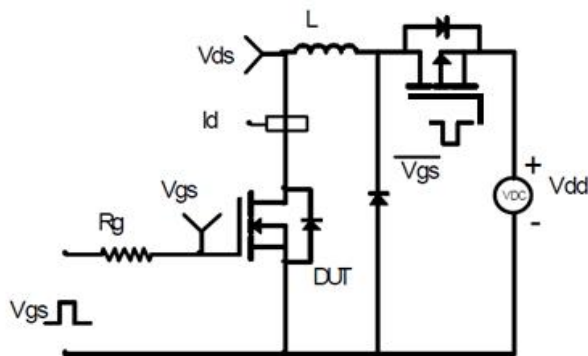

Mechanical Dimensions for TO-247

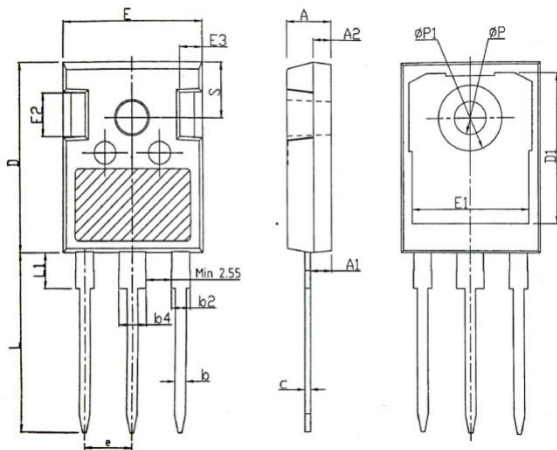

| SYMBOL | mm | | |
|--------|---------|-------|-------|
| | MIN | NOM | MAX |
| A | 4.80 | 5.00 | 5.20 |
| A1 | 2.21 | 2.41 | 2.59 |
| A2 | 1.85 | 2.00 | 2.15 |
| b | 1.11 | 1.21 | 1.36 |
| b2 | 1.91 | 2.01 | 2.21 |
| b4 | 2.91 | 3.01 | 3.21 |
| c | 0.51 | 0.61 | 0.75 |
| D | 20.80 | 21.00 | 21.30 |
| D1 | 16.25 | 16.55 | 16.85 |
| E | 15.50 | 15.80 | 16.10 |
| E1 | 13.00 | 13.30 | 13.60 |
| E2 | 4.80 | 5.00 | 5.20 |
| E3 | 2.30 | 2.50 | 2.70 |
| e | 5.44BSC | | |
| L | 19.82 | 19.92 | 20.22 |
| L1 | — | — | 4.30 |
| ØP | 3.40 | 3.60 | 3.80 |
| ØP1 | — | — | 7.30 |
| S | 6.15BSC | | |

TO-247 Part Marking Information

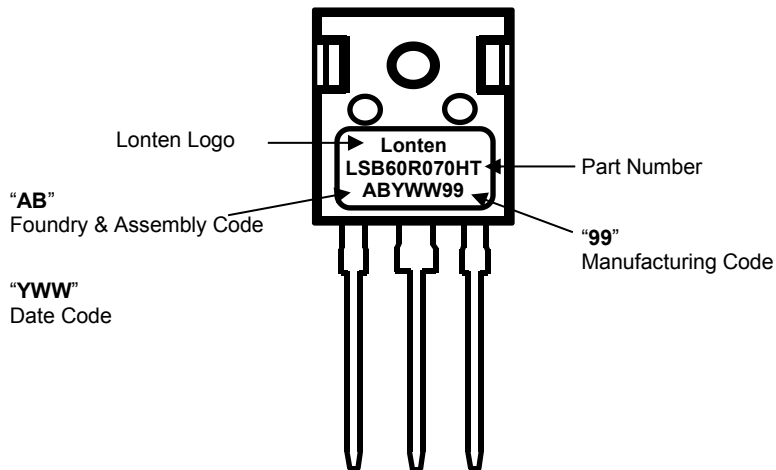

Mechanical Dimensions for TO-220MF

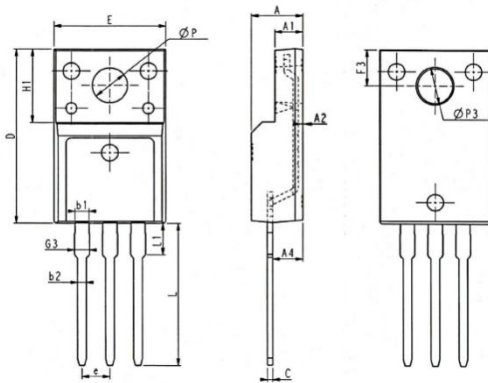

| SYMBOL | COMMON DIMENSIONS | | | | | |
|--------|-------------------|-------|-------|----------|-------|-------|
| | MM | | | INCH | | |
| | MIN | NOM | MAX | MIN | NOM | MAX |
| E | 9.96 | 10.16 | 10.36 | 0.392 | 0.400 | 0.408 |
| A | 4.50 | 4.70 | 4.90 | 0.177 | 0.185 | 0.193 |
| A1 | 2.34 | 2.54 | 2.74 | 0.092 | 0.100 | 0.108 |
| A2 | 0.30 | 0.45 | 0.60 | 0.012 | 0.020 | 0.024 |
| A4 | 2.65 | 2.76 | 2.96 | 0.104 | 0.109 | 0.117 |
| C | 0.40 | 0.50 | 0.65 | 0.016 | 0.020 | 0.026 |
| D | 15.57 | 15.87 | 16.17 | 0.613 | 0.625 | 0.637 |
| H1 | 6.70REF | | | 0.264REF | | |
| e | 2.54BSC | | | 0.1BSC | | |
| ØP | 3.03 | 3.18 | 3.38 | 0.119 | 0.125 | 0.133 |
| L | 12.68 | 12.98 | 13.28 | 0.499 | 0.511 | 0.523 |
| L1 | 2.88 | 3.03 | 3.18 | 0.113 | 0.119 | 0.125 |
| ØP3 | 3.15REF | | | 0.124REF | | |
| F3 | 3.15 | 3.30 | 3.45 | 0.124 | 0.130 | 0.136 |
| G3 | 1.25 | 1.35 | 1.55 | 0.049 | 0.053 | 0.061 |
| b1 | 1.18 | 1.28 | 1.43 | 0.046 | 0.050 | 0.056 |
| b2 | 0.70 | 0.80 | 0.95 | 0.028 | 0.031 | 0.037 |

TO-220MF Part Marking Information

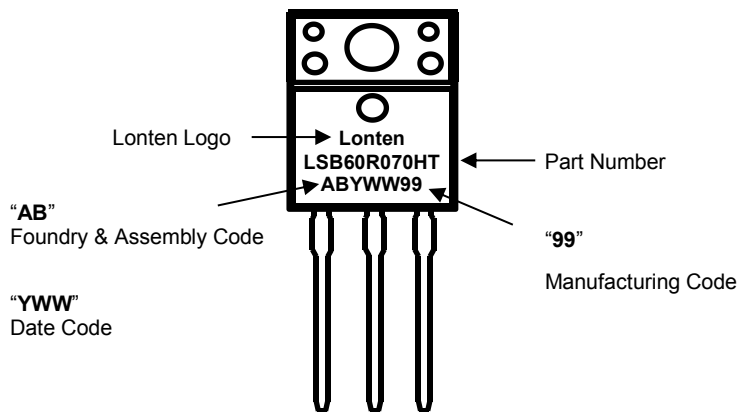

Disclaimer

The content specified herein is for the purpose of introducing LONTEN's products (hereinafter "Products"). The information given in this document shall in no event be regarded as a guarantee of conditions or characteristics. Examples of application circuits, circuit constants and any other information contained herein illustrate the standard usage and operations of the Products. The peripheral conditions must be taken into account when designing circuits for mass production.

LONTEN does not assume any liability for infringement of patents, copyrights, or other intellectual property rights of third parties by or arising from the use of the Products or technical information described in this document.

The Products are not designed or manufactured to be used with any equipment, device or system which requires an extremely high level of reliability the failure or malfunction of which may result in a direct threat to human life or create a risk of human injury (such as a medical instrument, transportation equipment, aerospace machinery, nuclear-reactor controller, fuel-controller or other safety device). LONTEN shall bear no responsibility in any way for use of any of the Products for the above special purposes.

Although LONTEN endeavors to improve the quality and reliability of its products, semiconductor products have specific characteristics such as the occurrence of failure at a certain rate and malfunctions under certain use conditions. Please be sure to implement safety measures to guard them against the possibility of physical injury, and injury or damage caused by fire in the event of the failure of a LONTEN product.

The content specified herein is subject to change for improvement without notice. When using a LONTEN product, be sure to obtain the latest specifications.

X-ON Electronics

Largest Supplier of Electrical and Electronic Components

Click to view similar products for [MOSFET](#) category:

Click to view products by [LONTEN](#) manufacturer:

Other Similar products are found below :

[614233C](#) [648584F](#) [MCH3443-TL-E](#) [MCH6422-TL-E](#) [FDPF9N50NZ](#) [FW216A-TL-2W](#) [FW231A-TL-E](#) [APT5010JVR](#) [NTNS3A92PZT5G](#)
[IRF100S201](#) [JANTX2N5237](#) [2SK2464-TL-E](#) [2SK3818-DL-E](#) [FCA20N60_F109](#) [FDZ595PZ](#) [STD6600NT4G](#) [FSS804-TL-E](#) [2SJ277-DL-E](#)
[2SK1691-DL-E](#) [2SK2545\(Q,T\)](#) [D2294UK](#) [405094E](#) [423220D](#) [MCH6646-TL-E](#) [TPCC8103,L1Q\(CM](#) [367-8430-0972-503](#) [VN1206L](#)
[424134F](#) [026935X](#) [051075F](#) [SBVS138LT1G](#) [614234A](#) [715780A](#) [NTNS3166NZT5G](#) [751625C](#) [873612G](#) [IRF7380TRHR](#)
[IPS70R2K0CEAKMA1](#) [RJK60S3DPP-E0#T2](#) [RJK60S5DPK-M0#T0](#) [APT5010JVFR](#) [APT12031JFLL](#) [APT12040JVR](#) [DMN3404LQ-7](#)
[NTE6400](#) [JANTX2N6796U](#) [JANTX2N6784U](#) [JANTXV2N5416U4](#) [SQM110N05-06L-GE3](#) [SIHF35N60E-GE3](#)