

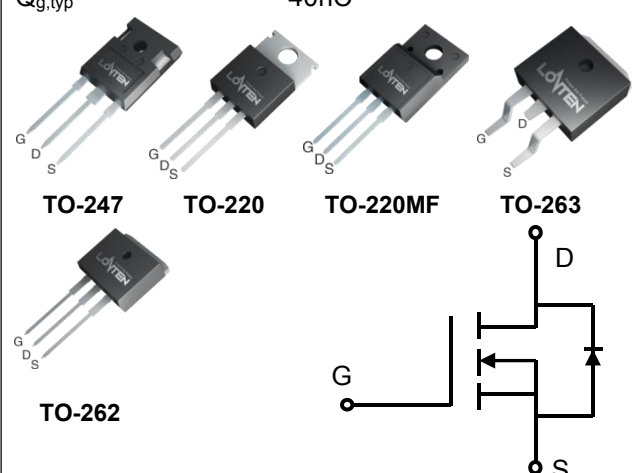
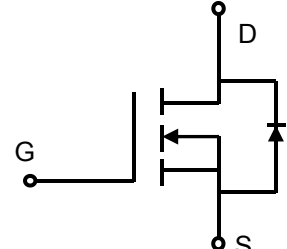

## Lonten N-channel 550V, 23A, 0.14Ω LonFET™ Power MOSFET

<p><b>Description</b> LonFET™ Power MOSFET is fabricated using advanced super junction technology. The resulting device has extremely low on resistance, making it especially suitable for applications which require superior power density and outstanding efficiency.</p> <p><b>Features</b></p> <ul style="list-style-type: none"> <li>◆ Ultra low <math>R_{DS(on)}</math></li> <li>◆ Ultra low gate charge (typ. <math>Q_g = 40\text{nC}</math>)</li> <li>◆ 100% UIS tested</li> <li>◆ RoHS compliant</li> </ul> <p><b>Applications</b></p> <ul style="list-style-type: none"> <li>◆ Power factor correction (PFC).</li> <li>◆ Switched mode power supplies (SMPS).</li> <li>◆ Uninterruptible power supply (UPS).</li> </ul>	<p><b>Product Summary</b></p> <table style="width: 100%; border-collapse: collapse;"> <tr> <td style="width: 60%;"><math>V_{DS} @ T_{j,max}</math></td> <td style="text-align: right;">600V</td> </tr> <tr> <td><math>R_{DS(on),max}</math></td> <td style="text-align: right;">0.14Ω</td> </tr> <tr> <td><math>I_{DM}</math></td> <td style="text-align: right;">69A</td> </tr> <tr> <td><math>Q_{g,typ}</math></td> <td style="text-align: right;">40nC</td> </tr> </table> <div style="text-align: center; margin-top: 10px;">  <p style="display: flex; justify-content: space-around; font-weight: bold; margin-top: 5px;"> <span>TO-247</span> <span>TO-220</span> <span>TO-220MF</span> <span>TO-263</span> </p> <p style="margin-top: 20px; font-weight: bold;">TO-262</p> </div> <div style="text-align: center; margin-top: 20px;">  <p style="margin-top: 10px; font-weight: bold;">N-Channel MOSFET</p> </div> <div style="text-align: right; margin-top: 10px;">  </div>	$V_{DS} @ T_{j,max}$	600V	$R_{DS(on),max}$	0.14Ω	$I_{DM}$	69A	$Q_{g,typ}$	40nC
$V_{DS} @ T_{j,max}$	600V								
$R_{DS(on),max}$	0.14Ω								
$I_{DM}$	69A								
$Q_{g,typ}$	40nC								

### Absolute Maximum Ratings

Parameter	Symbol	Value	Unit
Drain-Source Voltage	$V_{DSS}$	550	V
Continuous drain current ( $T_C = 25^\circ\text{C}$ ) ( $T_C = 100^\circ\text{C}$ )	$I_D$	23	A
		15	A
Pulsed drain current <sup>1)</sup>	$I_{DM}$	69	A
Gate-Source voltage	$V_{GSS}$	$\pm 30$	V
Avalanche energy, single pulse <sup>2)</sup>	$E_{AS}$	600	mJ
Avalanche energy, repetitive <sup>3)</sup>	$E_{AR}$	0.4	mJ
Avalanche current, repetitive <sup>3)</sup>	$I_{AR}$	23	A
Power Dissipation TO-247 ( $T_C = 25^\circ\text{C}$ ) - Derate above $25^\circ\text{C}$	$P_D$	205	W
		1.64	W/ $^\circ\text{C}$
Power Dissipation TO-220MF ( $T_C = 25^\circ\text{C}$ ) - Derate above $25^\circ\text{C}$	$P_D$	34	W
		0.28	W/ $^\circ\text{C}$
Mounting torque To-220MF ( M2.5 screws )		50	Ncm
Operating and Storage Temperature Range	$T_J, T_{STG}$	-55 to +150	$^\circ\text{C}$
Continuous diode forward current	$I_S$	23	A
Diode pulse current	$I_{S,pulse}$	69	A

**Thermal Characteristics TO-247/TO-263**

Parameter	Symbol	Value	Unit
Thermal Resistance, Junction-to-Case	$R_{\theta JC}$	0.61	$^{\circ}\text{C}/\text{W}$
Thermal Resistance, Junction-to-Ambient	$R_{\theta JA}$	60	$^{\circ}\text{C}/\text{W}$
Soldering temperature, wavesoldering only allowed at leads. (1.6mm from case for 10s)	$T_{\text{sold}}$	260	$^{\circ}\text{C}$

**Thermal Characteristics TO-220MF**

Parameter	Symbol	Value	Unit
Thermal Resistance, Junction-to-Case	$R_{\theta JC}$	3.6	$^{\circ}\text{C}/\text{W}$
Thermal Resistance, Junction-to-Ambient	$R_{\theta JA}$	80	$^{\circ}\text{C}/\text{W}$
Soldering temperature, wavesoldering only allowed at leads. (1.6mm from case for 10s)	$T_{\text{sold}}$	260	$^{\circ}\text{C}$

**Package Marking and Ordering Information**

Device	Device Package	Marking	Units/Tube	Units/Reel
LSB55R140GF	TO-247	LSB55R140GF	30	
LSC55R140GF	TO-220	LSC55R140GF	50	
LSD55R140GF	TO-220MF	LSD55R140GF	50	
LSE55R140GF	TO-263	LSE55R140GF		800
LSF55R140GF	TO-262	LSF55R140GF	50	

**Electrical Characteristics**  $T_c = 25^{\circ}\text{C}$  unless otherwise noted

Parameter	Symbol	Test Condition	Min.	Typ.	Max.	Unit
<b>Static characteristics</b>						
Drain-source breakdown voltage	$BV_{\text{DSS}}$	$V_{\text{GS}}=0\text{ V}, I_{\text{D}}=0.25\text{ mA}$	550	-	-	V
Gate threshold voltage	$V_{\text{GS(th)}}$	$V_{\text{DS}}=V_{\text{GS}}, I_{\text{D}}=0.25\text{ mA}$	3.0	3.5	4.5	V
Drain cut-off current	$I_{\text{DSS}}$	$V_{\text{DS}}=550\text{ V}, V_{\text{GS}}=0\text{ V},$ $T_j = 25^{\circ}\text{C}$ $T_j = 125^{\circ}\text{C}$	-	-	5	$\mu\text{A}$
Gate leakage current, Forward	$I_{\text{GSSF}}$	$V_{\text{GS}}=30\text{ V}, V_{\text{DS}}=0\text{ V}$	-	-	50	nA
Gate leakage current, Reverse	$I_{\text{GSSR}}$	$V_{\text{GS}}=-30\text{ V}, V_{\text{DS}}=0\text{ V}$	-	-	-50	nA
Drain-source on-state resistance	$R_{\text{DS(on)}}$	$V_{\text{GS}}=10\text{ V}, I_{\text{D}}=11.5\text{ A}$ $T_j = 25^{\circ}\text{C}$ $T_j = 150^{\circ}\text{C}$	-	0.11	0.14	$\Omega$
Gate resistance	$R_{\text{G}}$	$f=1\text{ MHz}, \text{open drain}$	-	4.5	-	$\Omega$
<b>Dynamic characteristics</b>						
Input capacitance	$C_{\text{iss}}$	$V_{\text{DS}} = 100\text{ V}, V_{\text{GS}} = 0\text{ V},$ $f = 250\text{ kHz}$	-	1730	-	pF
Output capacitance	$C_{\text{oss}}$		-	76.2	-	
Reverse transfer capacitance	$C_{\text{rss}}$		-	4.1	-	
Turn-on delay time	$t_{\text{d(on)}}$	$V_{\text{DD}} = 400\text{ V}, I_{\text{D}} = 11.5\text{ A}$	-	25	-	ns
Rise time	$t_{\text{r}}$	$R_{\text{G}} = 10\ \Omega, V_{\text{GS}}=10\text{ V}$	-	35	-	

Turn-off delay time	$t_{d(off)}$		-	97	-	
Fall time	$t_f$		-	12	-	
<b>Gate charge characteristics</b>						
Gate to source charge	$Q_{gs}$	$V_{DD}=400\text{ V}$ , $I_D=11.5\text{ A}$ , $V_{GS}=0\text{ to }10\text{ V}$	-	10	-	nC
Gate to drain charge	$Q_{gd}$		-	14	-	
Gate charge total	$Q_g$		-	40	-	
Gate plateau voltage	$V_{plateau}$		-	5.5	-	V
<b>Reverse diode characteristics</b>						
Diode forward voltage	$V_{SD}$	$V_{GS}=0\text{ V}$ , $I_F=11.5\text{ A}$	-	-	1.2	V
Reverse recovery time	$t_{rr}$	$V_R=50\text{ V}$ , $I_F=23\text{ A}$ , $di_F/dt=100\text{ A}/\mu\text{s}$	-	171	-	ns
Reverse recovery charge	$Q_{rr}$		-	1.5	-	$\mu\text{C}$
Peak reverse recovery current	$I_{rrm}$		-	16	-	A

**Notes:**

1. Limited by maximum junction temperature, maximum duty cycle is 0.75.
2.  $I_{AS} = 5\text{ A}$ ,  $V_{DD} = 60\text{ V}$ , Starting  $T_j = 25^\circ\text{C}$ .
3. Repetitive Rating: Pulse width limited by maximum junction temperature.

**Electrical Characteristics Diagrams**

Figure 1. On-Region Characteristics

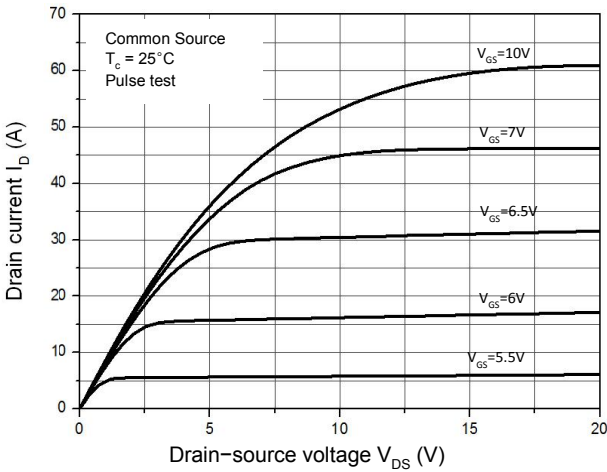

Figure 2. Transfer Characteristics

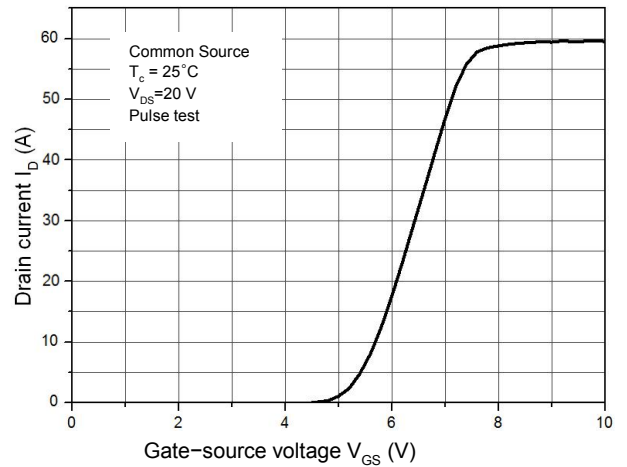

Figure 3. On-Resistance Variation vs. Drain Current

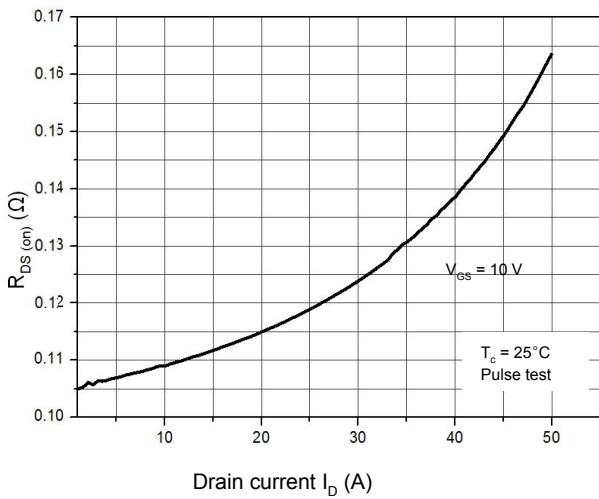

Figure 4. Threshold Voltage vs. Temperature

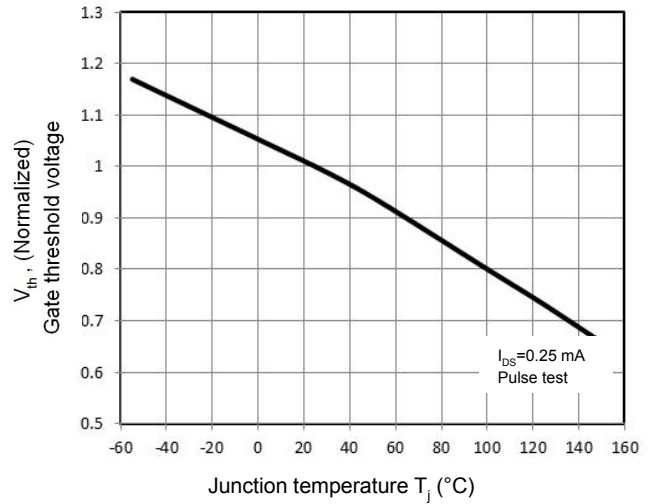

Figure 5. Breakdown Voltage vs. Temperature

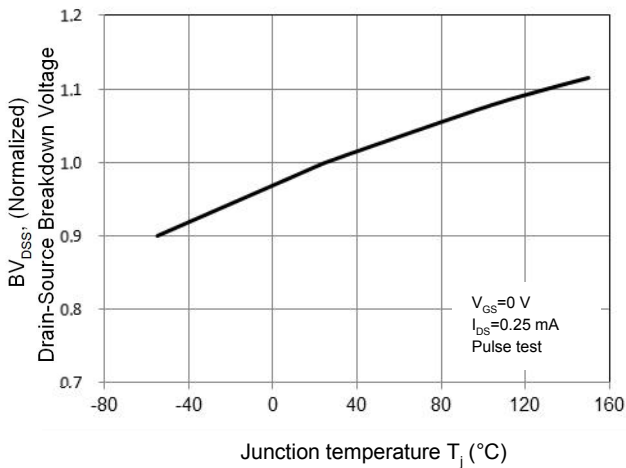

Figure 6. On-Resistance vs. Temperature

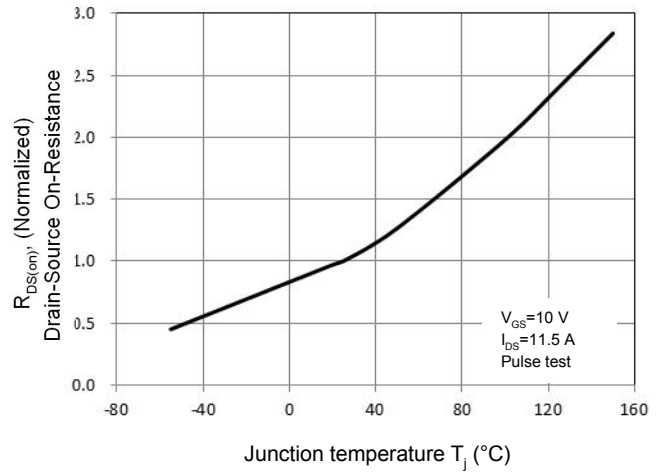

Figure 7. Capacitance Characteristics

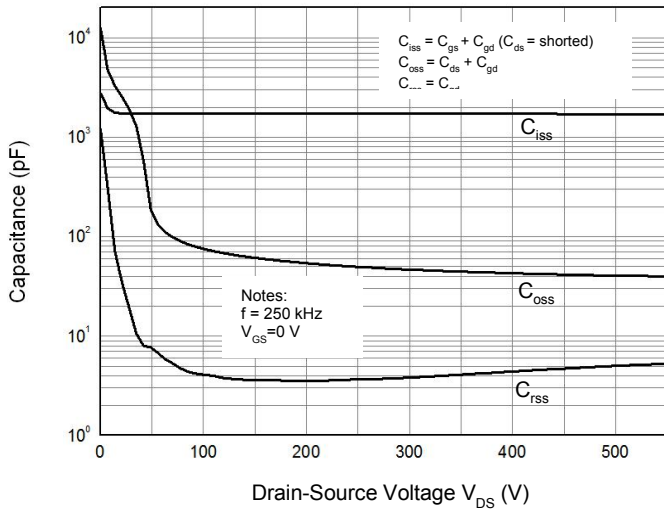

Figure 8. Gate Charge Characterist

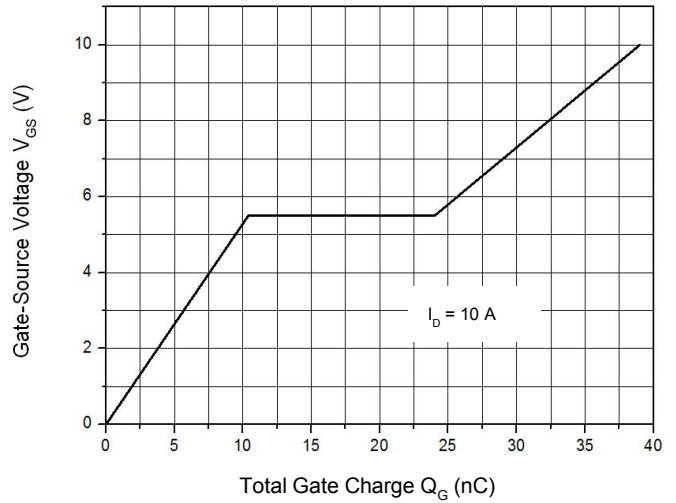

Figure 9.1 Maximum Safe Operating Area

TO-220MF

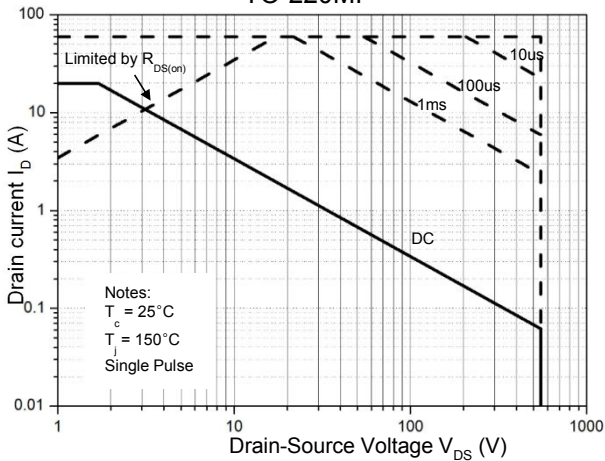

Figure 9.2 Maximum Safe Operating Area

TO-247/TO-263

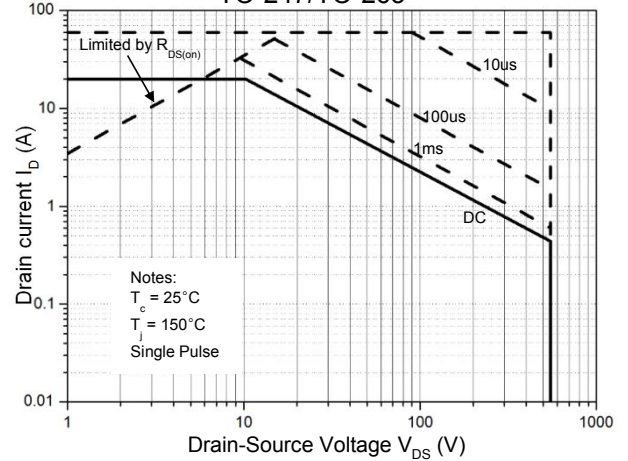

Figure 10.1 Power Dissipation vs. Temperature

TO-220MF

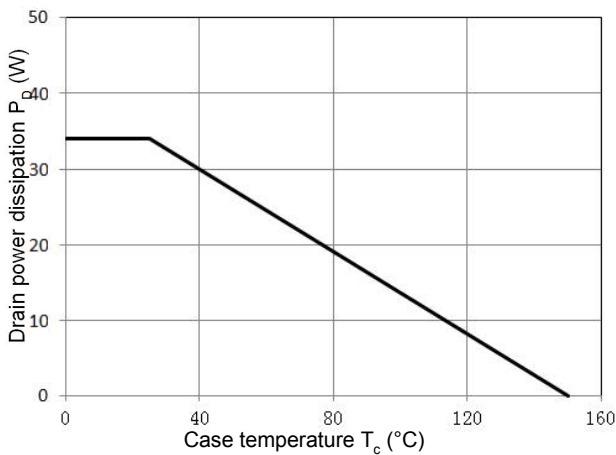

Figure 10.2 Power Dissipation vs. Temperature

TO-247/TO-263

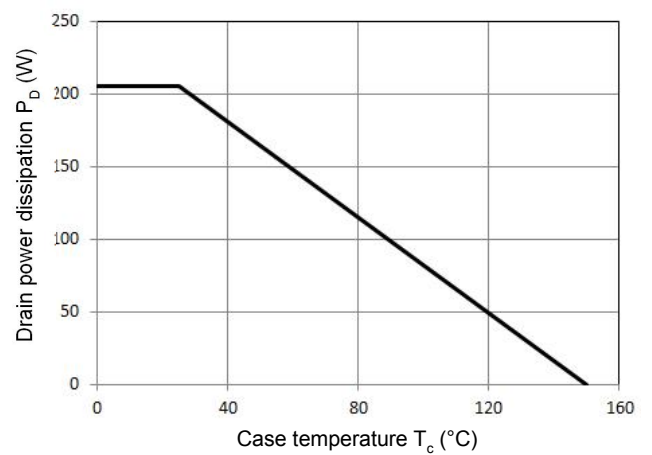

Figure 11.1 Transient Thermal Response Curve

TO-220MF

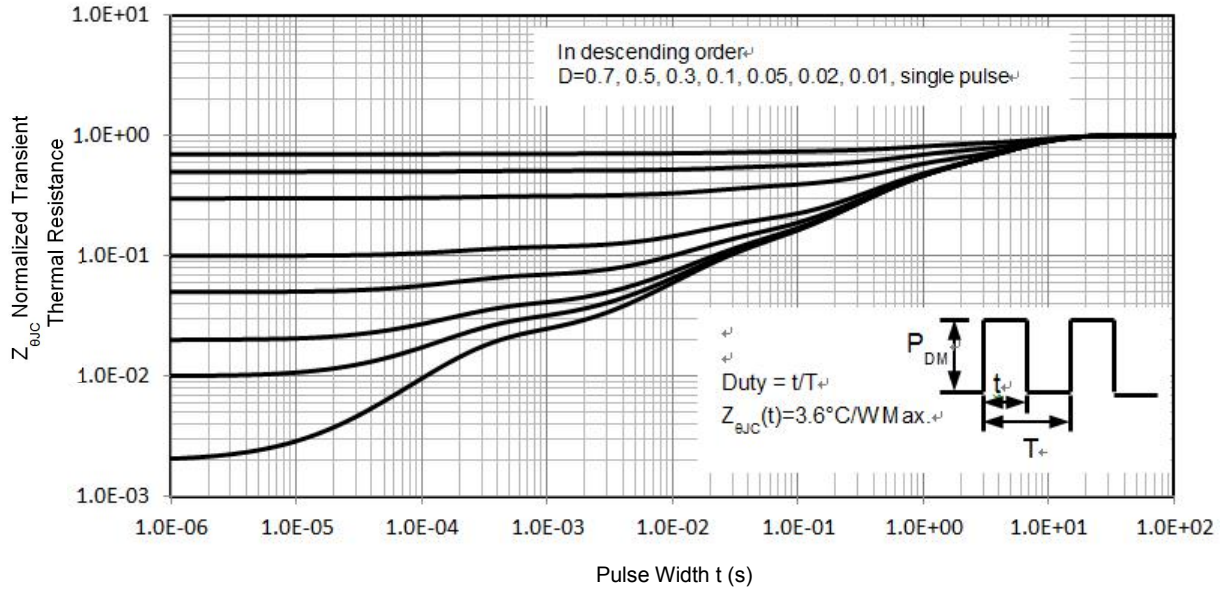
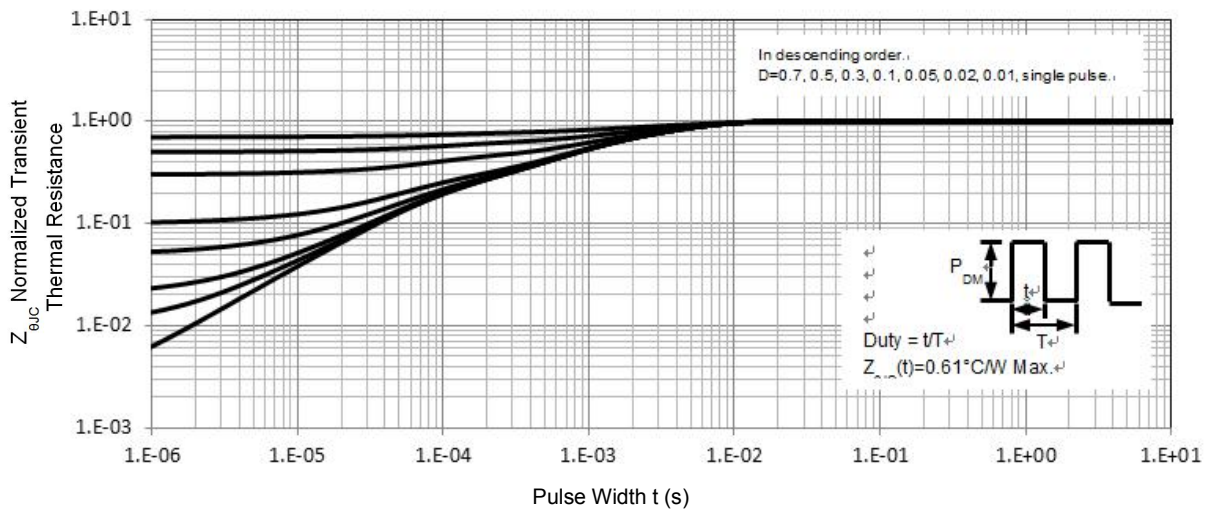
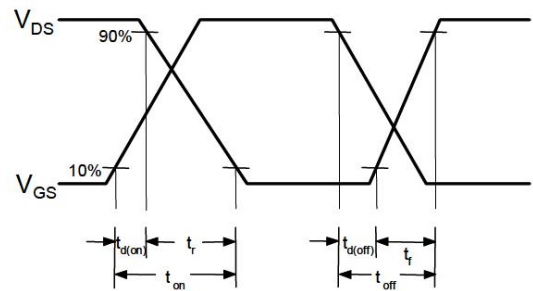
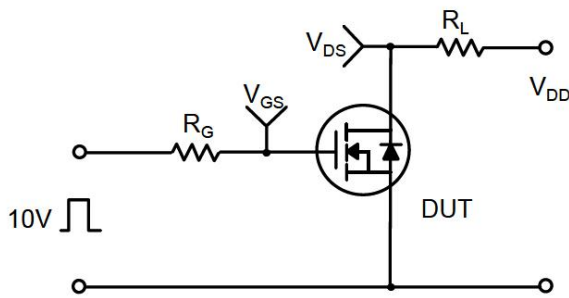
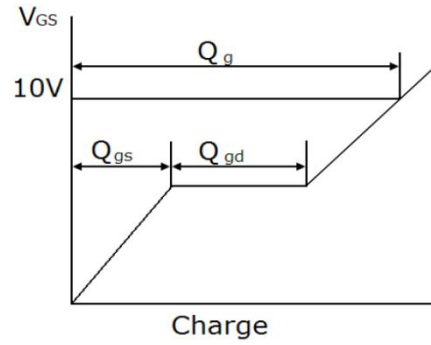
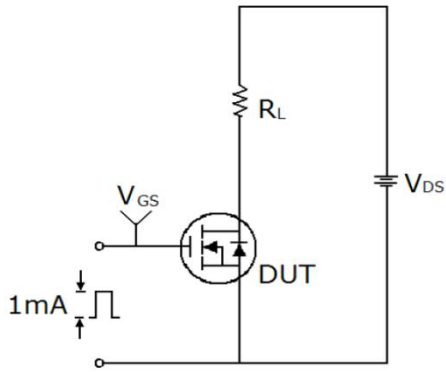

Figure 11.1 Transient Thermal Response Curve

TO-247/TO-263



**Gate Charge Test Circuit & Waveform**



**Unclamped Inductive Switching Test Circuit & Waveforms**

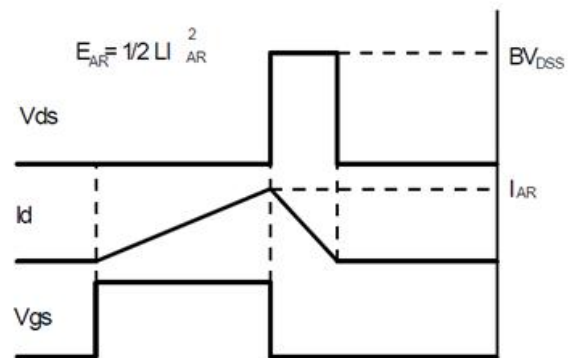
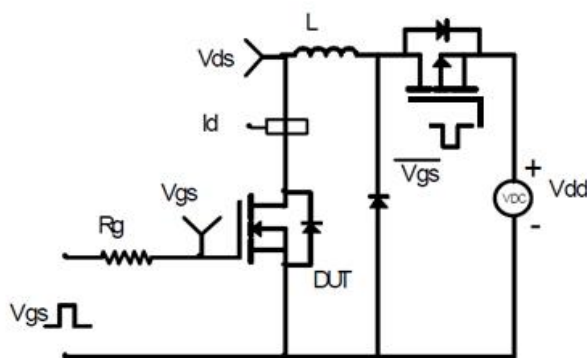

**Mechanical Dimensions for TO-220**

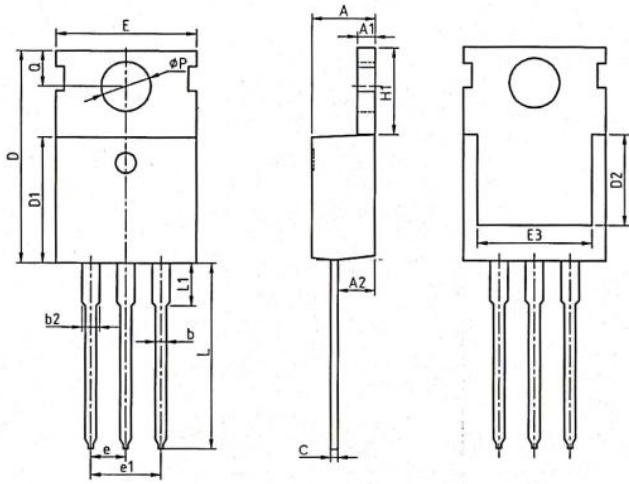

COMMON DIMENSIONS						
SYMBOL	MM			INCH		
	MIN	NOM	MAX	MIN	NOM	MAX
A	4.37	4.57	4.70	0.172	0.180	0.185
A1	1.25	1.30	1.40	0.049	0.051	0.055
A2	2.20	2.40	2.60	0.087	0.094	0.102
b	0.70	0.80	0.95	0.028	0.031	0.037
b2	1.17	1.27	1.47	0.046	0.050	0.058
c	0.45	0.50	0.60	0.018	0.020	0.024
D	15.10	15.60	16.10	0.594	0.614	0.634
D1	8.80	9.10	9.40	0.346	0.358	0.370
D2	5.50	—	—	0.217	—	—
E	9.70	10.00	10.30	0.382	0.394	0.406
E3	7.00	—	—	0.276	—	—
e	2.54BSC			0.1BSC		
e1	5.08BSC			0.2BSC		
H1	6.25	6.50	6.85	0.246	0.256	0.270
L	12.75	13.50	13.80	0.502	0.531	0.543
L1	—	3.10	3.40	—	0.122	0.134
øp	3.40	3.60	3.80	0.134	0.142	0.150
Q	2.60	2.80	3.00	0.102	0.110	0.118

**TO-220 Part Marking Information**

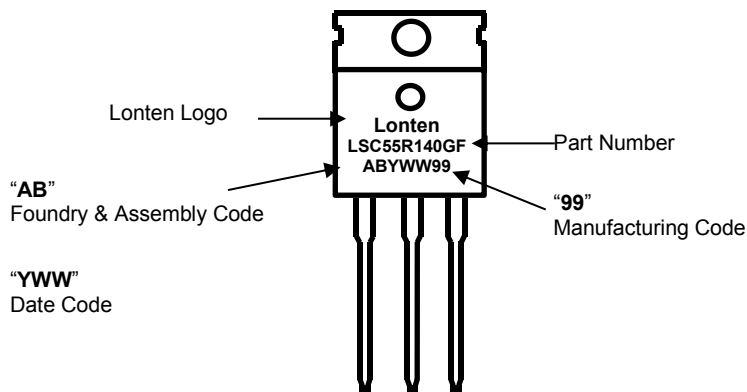



**Mechanical Dimensions for TO-247**

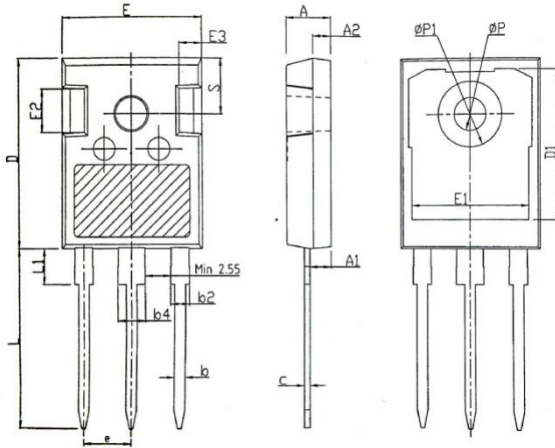

SYMBOL	mm		
	MIN	NOM	MAX
A	4.80	5.00	5.20
A1	2.21	2.41	2.59
A2	1.85	2.00	2.15
b	1.11	1.21	1.36
b2	1.91	2.01	2.21
b4	2.91	3.01	3.21
c	0.51	0.61	0.75
D	20.80	21.00	21.30
D1	16.25	16.55	16.85
E	15.50	15.80	16.10
E1	13.00	13.30	13.60
E2	4.80	5.00	5.20
E3	2.30	2.50	2.70
e	5.44BSC		
L	19.82	19.92	20.22
L1	—	—	4.30
ØP	3.40	3.60	3.80
ØP1	—	—	7.30
S	6.15BSC		

**TO-247 Part Marking Information**

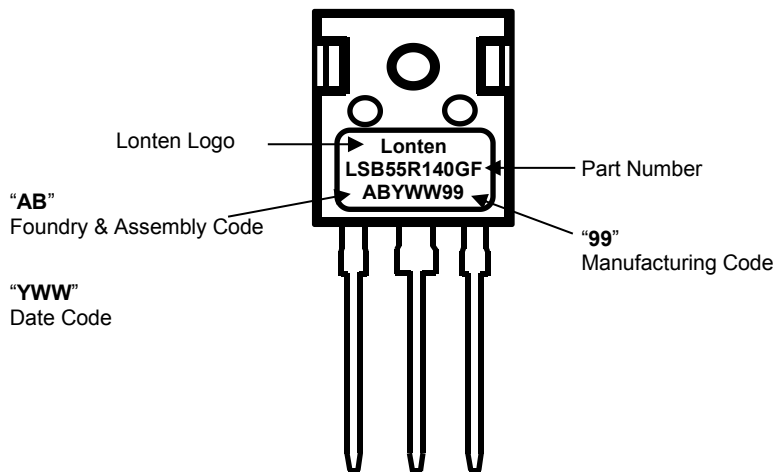

**Mechanical Dimensions for TO-220MF**

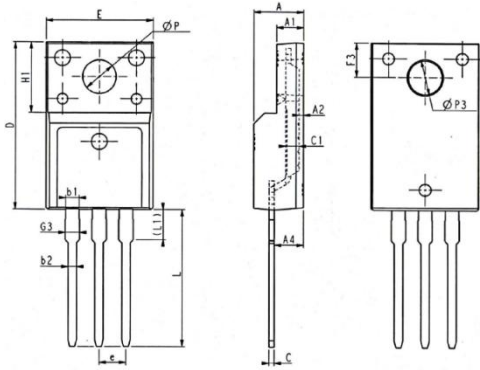

SYMBOL	COMMON DIMENSIONS					
	MM			INCH		
	MIN	NOM	MAX	MIN	NOM	MAX
E	9.96	10.16	10.36	0.392	0.400	0.408
A	4.50	4.70	4.90	0.177	0.185	0.193
A1	2.34	2.54	2.74	0.092	0.100	0.108
A2	0.30	0.45	0.60	0.012	0.020	0.024
A4	2.65	2.76	2.96	0.104	0.109	0.117
C	0.40	0.50	0.65	0.016	0.020	0.026
C1	1.20	1.30	1.35			
D	15.57	15.87	16.17	0.613	0.625	0.637
H1	6.70REF			0.264REF		
e	2.54BSC			0.1BSC		
L	12.68	12.98	13.28	0.499	0.511	0.523
L1	2.88	3.03	3.18	0.113	0.119	0.125
ØP	3.03	3.18	3.38	0.119	0.125	0.133
ØP3	3.15	3.45	3.65	0.124	0.136	0.144
F3	3.15	3.30	3.45	0.124	0.130	0.136
G3	1.25	1.35	1.55	0.049	0.053	0.061
b1	1.18	1.28	1.43	0.046	0.050	0.056
b2	0.70	0.80	0.95	0.028	0.031	0.037

**TO-220MF Part Marking Information**

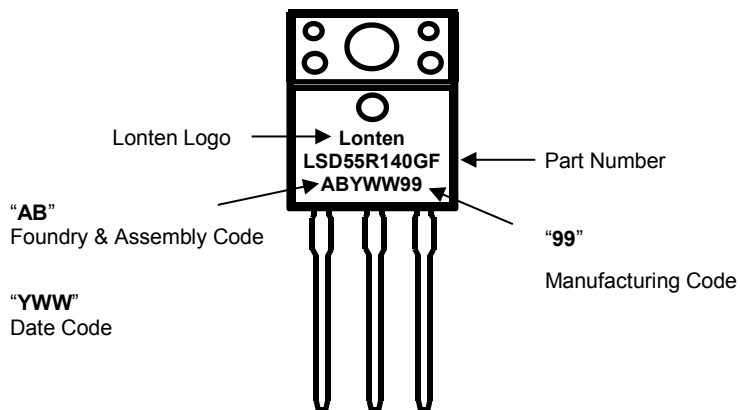

**Mechanical Dimensions for TO-263**

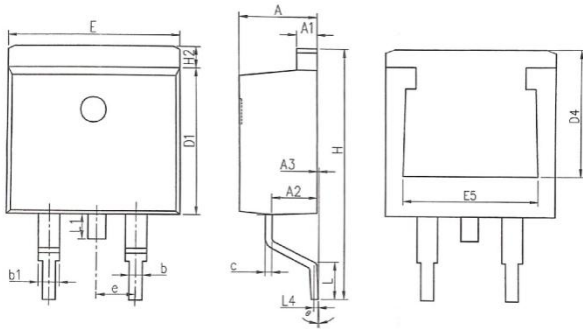

SYMBOL	COMMON DIMENSIONS					
	MM			INCH		
	MIN	NOM	MAX	MIN	NOM	MAX
A	4.37	4.57	4.77	0.172	0.180	0.188
A1	1.22	1.27	1.42	0.048	0.050	0.056
A2	2.49	2.89	2.89	0.098	0.114	0.114
A3	0.00	0.13	0.25	0.000	0.005	0.010
b	0.70	0.81	0.96	0.028	0.032	0.034
b1	1.17	1.27	1.47	0.046	0.050	0.058
c	0.30	0.38	0.53	0.012	0.015	0.021
D1	8.50	8.70	8.90	0.335	0.343	0.350
D4	6.60	—	—	0.260	—	—
E	9.86	10.16	10.36	0.389	0.400	0.408
E5	7.06	—	—	0.278	—	—
e	2.54 BSC			0.100 BSC		
H	14.70	15.10	15.50	0.579	0.594	0.610
H2	1.07	1.27	1.47	0.042	0.050	0.058
L	2.00	2.30	2.60	0.079	0.091	0.102
L1	1.40	1.55	1.70	0.055	0.061	0.067
L4	0.25 BSC			0.010 BSC		
θ	0°	5°	9°	0°	0.197°	0.354°

**TO-263 Part Marking Information**

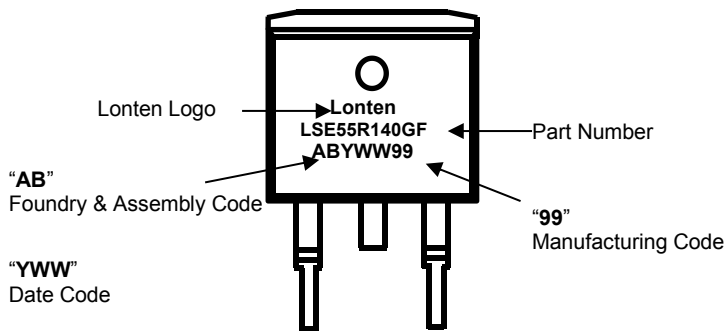

**Mechanical Dimensions for TO-262**

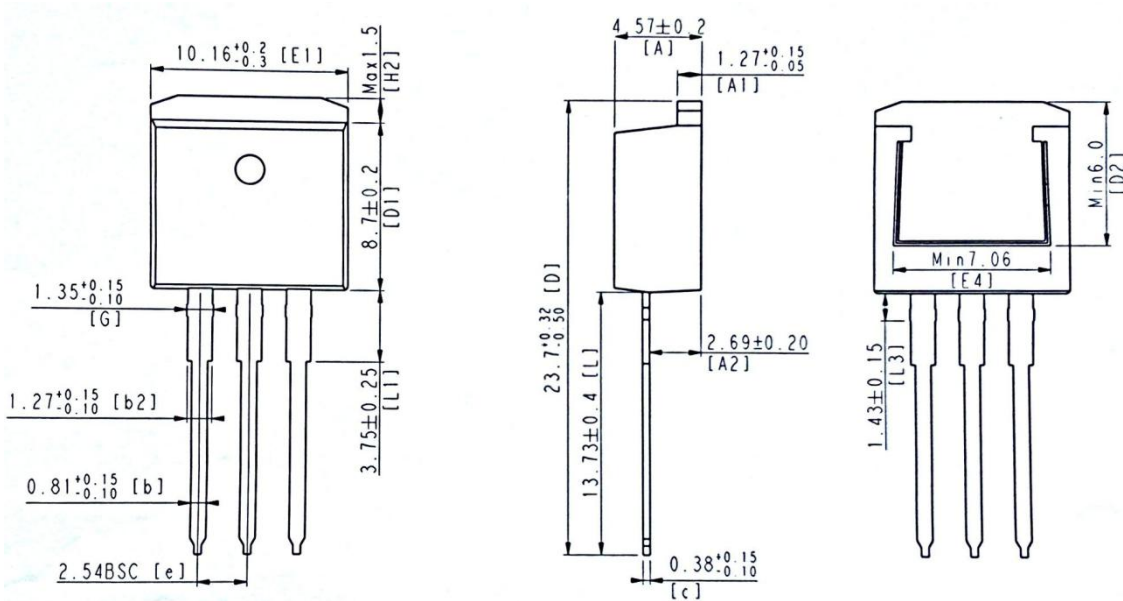

**TO-262 Part Marking Information**

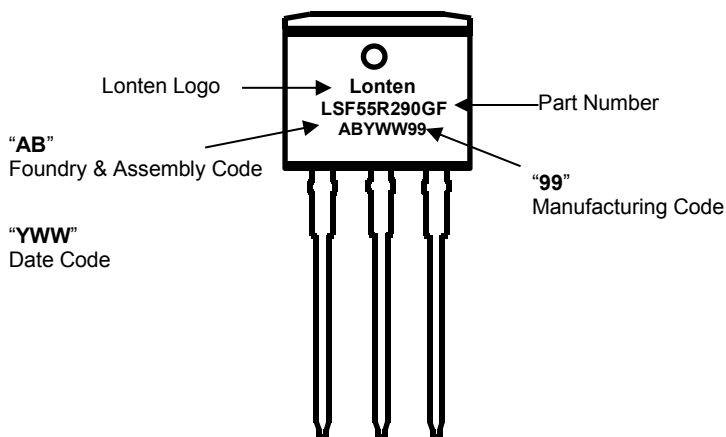

---

**Disclaimer**

The content specified herein is for the purpose of introducing LONTEN's products (hereinafter "Products"). The information given in this document shall in no event be regarded as a guarantee of conditions or characteristics. Examples of application circuits, circuit constants and any other information contained herein illustrate the standard usage and operations of the Products. The peripheral conditions must be taken into account when designing circuits for mass production.

LONTEN does not assume any liability for infringement of patents, copyrights, or other intellectual property rights of third parties by or arising from the use of the Products or technical information described in this document.

The Products are not designed or manufactured to be used with any equipment, device or system which requires an extremely high level of reliability the failure or malfunction of which may result in a direct threat to human life or create a risk of human injury (such as a medical instrument, transportation equipment, aerospace machinery, nuclear-reactor controller, fuel-controller or other safety device). LONTEN shall bear no responsibility in any way for use of any of the Products for the above special purposes.

Although LONTEN endeavors to improve the quality and reliability of its products, semiconductor products have specific characteristics such as the occurrence of failure at a certain rate and malfunctions under certain use conditions. Please be sure to implement safety measures to guard them against the possibility of physical injury, and injury or damage caused by fire in the event of the failure of a LONTEN product.

The content specified herein is subject to change for improvement without notice. When using a LONTEN product, be sure to obtain the latest specifications.

## X-ON Electronics

Largest Supplier of Electrical and Electronic Components

*Click to view similar products for [MOSFET](#) category:*

*Click to view products by [LONTEN](#) manufacturer:*

Other Similar products are found below :

[614233C](#) [648584F](#) [MCH3443-TL-E](#) [MCH6422-TL-E](#) [FDPF9N50NZ](#) [FW216A-TL-2W](#) [FW231A-TL-E](#) [APT5010JVR](#) [NTNS3A92PZT5G](#)  
[IRF100S201](#) [JANTX2N5237](#) [2SK2464-TL-E](#) [2SK3818-DL-E](#) [FCA20N60\\_F109](#) [FDZ595PZ](#) [STD6600NT4G](#) [FSS804-TL-E](#) [2SJ277-DL-E](#)  
[2SK1691-DL-E](#) [2SK2545\(Q,T\)](#) [D2294UK](#) [405094E](#) [423220D](#) [MCH6646-TL-E](#) [TPCC8103,L1Q\(CM](#) [367-8430-0972-503](#) [VN1206L](#)  
[424134F](#) [026935X](#) [051075F](#) [SBVS138LT1G](#) [614234A](#) [715780A](#) [NTNS3166NZT5G](#) [751625C](#) [873612G](#) [IRF7380TRHR](#)  
[IPS70R2K0CEAKMA1](#) [RJK60S3DPP-E0#T2](#) [RJK60S5DPK-M0#T0](#) [APT5010JVFR](#) [APT12031JFLL](#) [APT12040JVR](#) [DMN3404LQ-7](#)  
[NTE6400](#) [JANTX2N6796U](#) [JANTX2N6784U](#) [JANTXV2N5416U4](#) [SQM110N05-06L-GE3](#) [SIHF35N60E-GE3](#)