

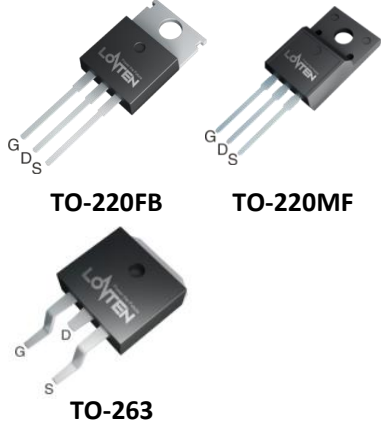
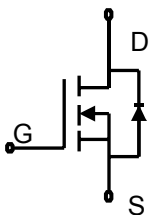

## Lonten N-channel 100V, 80A, 8mΩ Power MOSFET

|   |   |           |      |                             |     |       |     |
|---|---|-----------|------|-----------------------------|-----|-------|-----|
| <p><b>Description</b><br/>                 These N-Channel enhancement mode power field effect transistors are using split gate trench DMOS technology. This advanced technology has been especially tailored to minimize on-state resistance, provide superior switching performance, and with stand high energy pulse in the avalanche and commutation mode. These devices are well suited for high efficiency fast switching applications.</p> <p><b>Features</b></p> <ul style="list-style-type: none"> <li>◆ 100V,80A,<math>R_{DS(ON),max}=8m\Omega@V_{GS}=10V</math></li> <li>◆ Improved dv/dt capability</li> <li>◆ Fast switching</li> <li>◆ 100% EAS Guaranteed</li> <li>◆ Green device available</li> </ul> <p><b>Applications</b></p> <ul style="list-style-type: none"> <li>◆ Motor Drives</li> <li>◆ UPS</li> <li>◆ DC-DC Converter</li> </ul> | <p><b>Product Summary</b></p> <table style="width: 100%; border: none;"> <tr> <td style="padding: 2px;"><math>V_{DSS}</math></td> <td style="padding: 2px; text-align: right;">100V</td> </tr> <tr> <td style="padding: 2px;"><math>R_{DS(on),max}@V_{GS}=10V</math></td> <td style="padding: 2px; text-align: right;">8mΩ</td> </tr> <tr> <td style="padding: 2px;"><math>I_D</math></td> <td style="padding: 2px; text-align: right;">80A</td> </tr> </table> <p><b>Pin Configuration</b></p> <div style="text-align: center;">  <p><b>TO-220FB      TO-220MF</b></p> <p><b>TO-263</b></p> </div> <div style="text-align: center;">  <p><b>N-Channel MOSFET</b></p>  </div> | $V_{DSS}$ | 100V | $R_{DS(on),max}@V_{GS}=10V$ | 8mΩ | $I_D$ | 80A |
| $V_{DSS}$   | 100V  |           |      |                             |     |       |     |
| $R_{DS(on),max}@V_{GS}=10V$   | 8mΩ   |           |      |                             |     |       |     |
| $I_D$   | 80A   |           |      |                             |     |       |     |

### Absolute Maximum Ratings $T_C = 25^\circ\text{C}$ unless otherwise noted

| Parameter   | Symbol    | Value       | Unit             |
|---|-----------|-------------|------------------|
| Drain-Source Voltage  | $V_{DSS}$ | 100         | V                |
| Continuous drain current ( $T_C = 25^\circ\text{C}$ )             | $I_D$     | 80          | A                |
| Continuous drain current ( $T_C = 100^\circ\text{C}$ )            |           | 60          | A                |
| Pulsed drain current <sup>(note 1)</sup>                          | $I_{DM}$  | 320         | A                |
| Gate-Source voltage   | $V_{GSS}$ | $\pm 20$    | V                |
| Avalanche energy, single pulse <sup>(note 2)</sup>                | $E_{AS}$  | 110         | mJ               |
| Power Dissipation ( $T_C = 25^\circ\text{C}$ ) TO-220FB/TO-263-2L | $P_D$     | 150         | W                |
| Power Dissipation ( $T_C = 25^\circ\text{C}$ ) TO-220MF           | $P_D$     | 48          | W                |
| Storage Temperature Range   | $T_{STG}$ | -55 to +150 | $^\circ\text{C}$ |
| Operating Junction Temperature Range                              | $T_J$     | -55 to +150 | $^\circ\text{C}$ |

### Thermal Characteristics

| Parameter  | Symbol          | Value | Unit               |
|--|-----------------|-------|--------------------|
| Thermal Resistance, Junction-to-Case TO-220FB/TO-263-2L    | $R_{\theta JC}$ | 0.83  | $^\circ\text{C/W}$ |
| Thermal Resistance, Junction-to-Case TO-220MF              |                 | 2.6   | $^\circ\text{C/W}$ |
| Thermal Resistance, Junction-to-Ambient TO-220FB/TO-263-2L | $R_{\theta JA}$ | 62    | $^\circ\text{C/W}$ |
| Thermal Resistance, Junction-to-Case TO-220MF              |                 | 80    | $^\circ\text{C/W}$ |

**Package Marking and Ordering Information**

| Device       | Device Package | Marking      |
|--------------|----------------|--------------|
| LSGC10R080W3 | TO-220FB       | LSGC10R080W3 |
| LSGD10R080W3 | TO-220MF       | LSGD10R080W3 |
| LSGE10R080W3 | TO-263         | LSGE10R080W3 |

**Electrical Characteristics**  $T_J = 25^\circ\text{C}$  unless otherwise noted

| Parameter   | Symbol       | Test Condition   | Min. | Typ. | Max. | Unit          |
|---|--------------|--|------|------|------|---------------|
| <b>Static characteristics</b>                                 |              |  |      |      |      |               |
| Drain-source breakdown voltage                                | $BV_{DSS}$   | $V_{GS}=0\text{ V}, I_D=250\mu\text{A}$                                    | 100  | ---  | ---  | V             |
| Gate threshold voltage  | $V_{GS(th)}$ | $V_{DS}=V_{GS}, I_D=250\mu\text{A}$  | 1.4  | 1.8  | 2.2  | V             |
| Drain-source leakage current                                  | $I_{DSS}$    | $V_{DS}=100\text{V}, V_{GS}=0\text{V}, T_J = 25^\circ\text{C}$             | ---  | ---  | 1    | $\mu\text{A}$ |
|   |              | $V_{DS}=80\text{V}, V_{GS}=0\text{V}, T_J = 125^\circ\text{C}$             | ---  | ---  | 10   | $\mu\text{A}$ |
| Gate leakage current, Forward                                 | $I_{GSSF}$   | $V_{GS}=20\text{ V}, V_{DS}=0\text{ V}$                                    | ---  | ---  | 100  | nA            |
| Gate leakage current, Reverse                                 | $I_{GSSR}$   | $V_{GS}=-20\text{ V}, V_{DS}=0\text{ V}$                                   | ---  | ---  | -100 | nA            |
| Drain-source on-state resistance <sup>(note 3)</sup>          | $R_{DS(on)}$ | $V_{GS}=10\text{ V}, I_D=50\text{ A}$                                      | ---  | 6.8  | 8    | m $\Omega$    |
| Drain-source on-state resistance <sup>(note 3)</sup>          |              | $V_{GS}=4.5\text{ V}, I_D=40\text{ A}$                                     | ---  | 8.3  | 10   | m $\Omega$    |
| Forward transconductance                                      | $g_{fs}$     | $V_{DS}=5\text{V}, I_D=50\text{A}$   | ---  | 112  | ---  | S             |
| <b>Dynamic characteristics</b>                                |              |  |      |      |      |               |
| Input capacitance   | $C_{iss}$    | $V_{DS} = 50\text{ V}, V_{GS} = 0\text{ V},$<br>$F = 1\text{MHz}$          | ---  | 2630 | ---  | pF            |
| Output capacitance  | $C_{oss}$    |  | ---  | 453  | ---  |               |
| Reverse transfer capacitance                                  | $C_{rss}$    |  | ---  | 36   | ---  |               |
| Turn-on delay time <sup>(note 3,4)</sup>                      | $t_{d(on)}$  | $V_{DD} = 50\text{V}, V_{GS}=10\text{V}, I_D = 50\text{A}$                 | ---  | 10.5 | ---  | ns            |
| Rise time <sup>(note 3,4)</sup>                               | $t_r$        |  | ---  | 63   | ---  |               |
| Turn-off delay time <sup>(note 3,4)</sup>                     | $t_{d(off)}$ |  | ---  | 30   | ---  |               |
| Fall time <sup>(note 3,4)</sup>                               | $t_f$        |  | ---  | 96   | ---  |               |
| Gate resistance   | $R_g$        | $V_{GS}=0\text{V}, V_{DS}=0\text{V}, F=1\text{MHz}$                        | ---  | 1.1  | ---  | $\Omega$      |
| <b>Gate charge characteristics</b>                            |              |  |      |      |      |               |
| Gate to source charge <sup>(note 3,4)</sup>                   | $Q_{gs}$     | $V_{DS}=50\text{ V}, I_D=50\text{A},$<br>$V_{GS}= 10\text{ V}$             | ---  | 10.2 | ---  | nC            |
| Gate to drain charge <sup>(note 3,4)</sup>                    | $Q_{gd}$     |  | ---  | 6.6  | ---  |               |
| Gate charge total <sup>(note 3,4)</sup>                       | $Q_g$        |  | ---  | 45   | ---  |               |
| <b>Drain-Source diode characteristics and Maximum Ratings</b> |              |  |      |      |      |               |
| Continuous Source Current                                     | $I_S$        | $V_G=V_D=0\text{ V}, \text{Force Current}$                                 | ---  | ---  | 80   | A             |
| Pulsed Source Current <sup>(note 3)</sup>                     | $I_{SM}$     |  | ---  | ---  | 320  | A             |
| Diode Forward Voltage <sup>(note 3)</sup>                     | $V_{SD}$     | $V_{GS}=0\text{V}, I_S=50\text{A}, T_J=25^\circ\text{C}$                   | ---  | 0.95 | 1.3  | V             |
| Reverse Recovery Time   | $t_{rr}$     | $I_S=50\text{A}, di/dt=100\text{A}/\mu\text{s},$<br>$T_J=25^\circ\text{C}$ | ---  | 65   | ---  | ns            |
| Reverse Recovery Charge                                       | $Q_{rr}$     |  | ---  | 104  | ---  | nC            |

**Notes:**

- 1: Repetitive Rating: Pulse width limited by maximum junction temperature.
- 2:  $V_{DD}=50\text{V}, V_{GS}=10\text{V}, L=0.5\text{mH}, I_{AS}=21\text{A}, R_G=25\Omega,$  Starting  $T_J=25^\circ\text{C}$ .
- 3: Pulse Test: Pulse Width  $\leq 300\ \mu\text{s}$ , Duty Cycle  $\leq 2\%$ .
- 4: Essentially independent of operating temperature.

**Electrical Characteristics Diagrams**

Figure 1. Typ. Output Characteristics

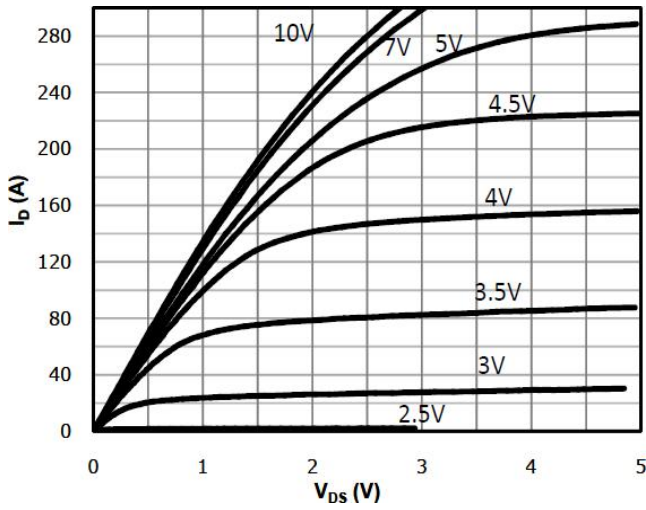

Figure 3. Capacitance Characteristics

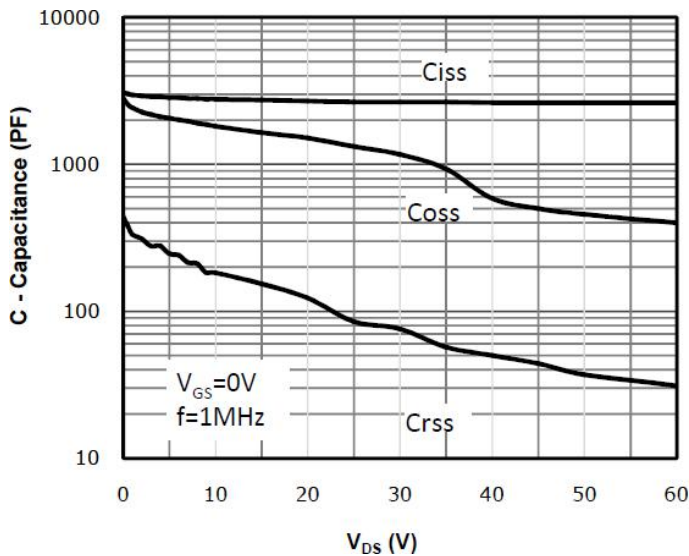

Figure 5. Body-Diode Characteristics

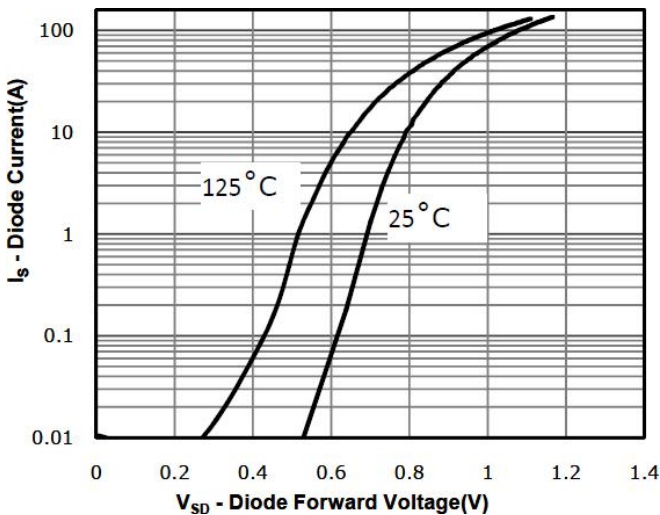

Figure 2. Transfer Characteristics

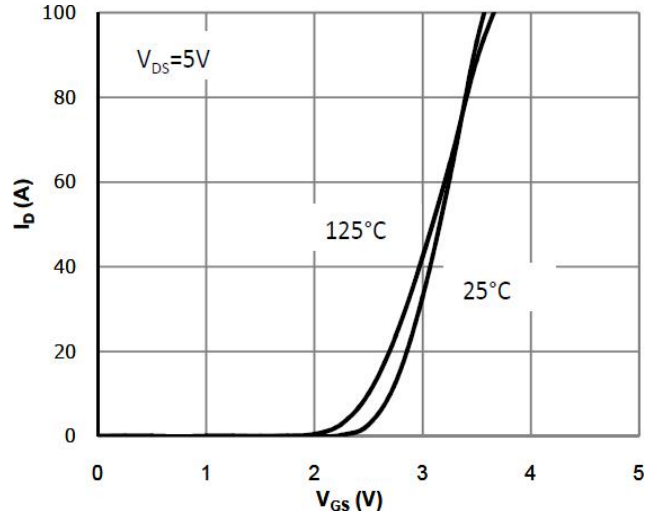

Figure 4. Gate Charge Waveform

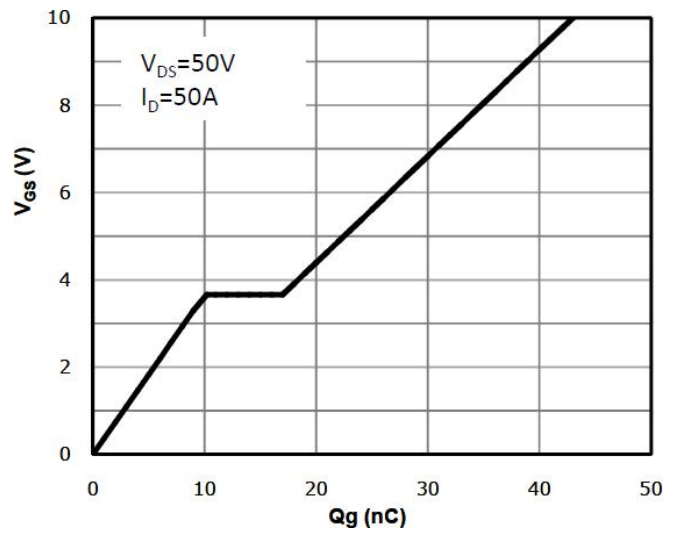

Figure 6. Rds(on)-Drain Current

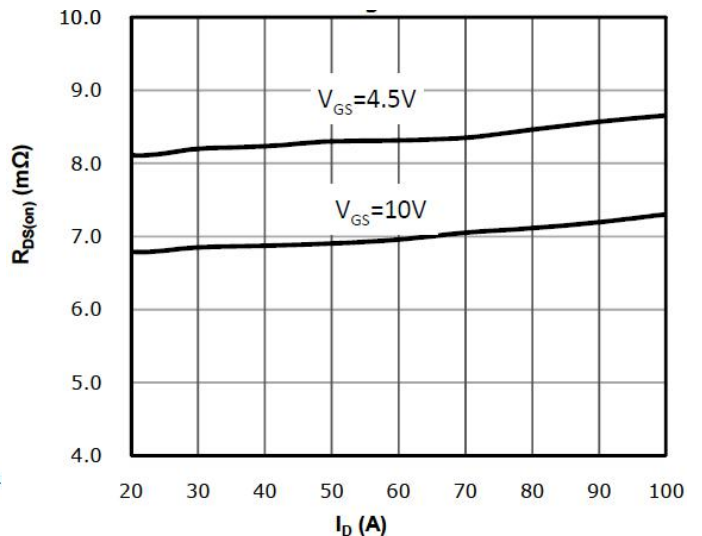

Figure 7. R<sub>ds(on)</sub>-Junction Temperature(°C)

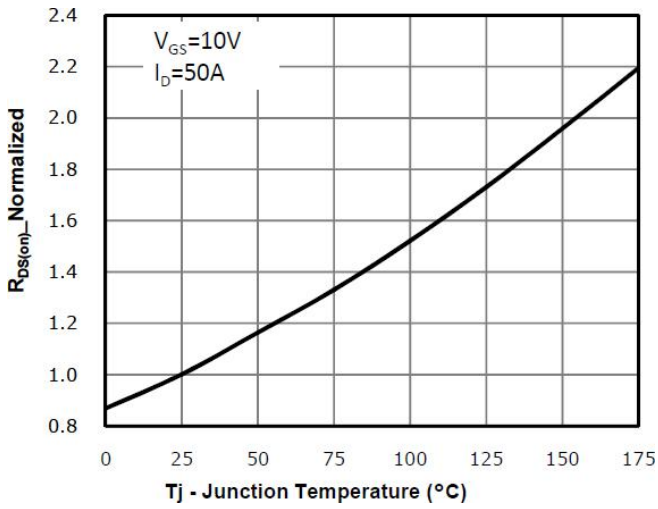

Figure 8. Maximum Safe Operating Area

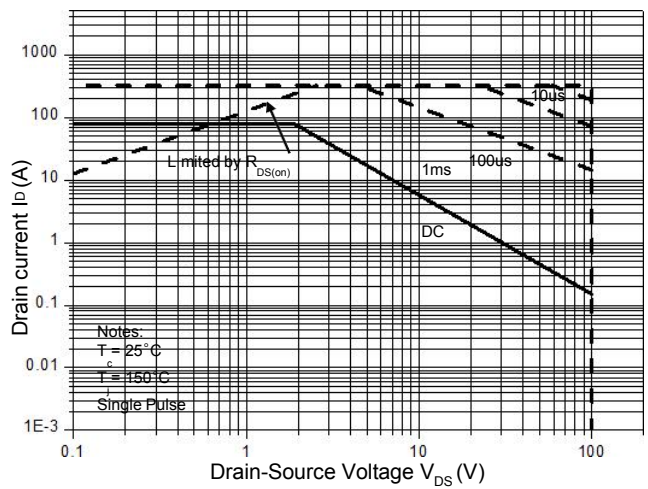
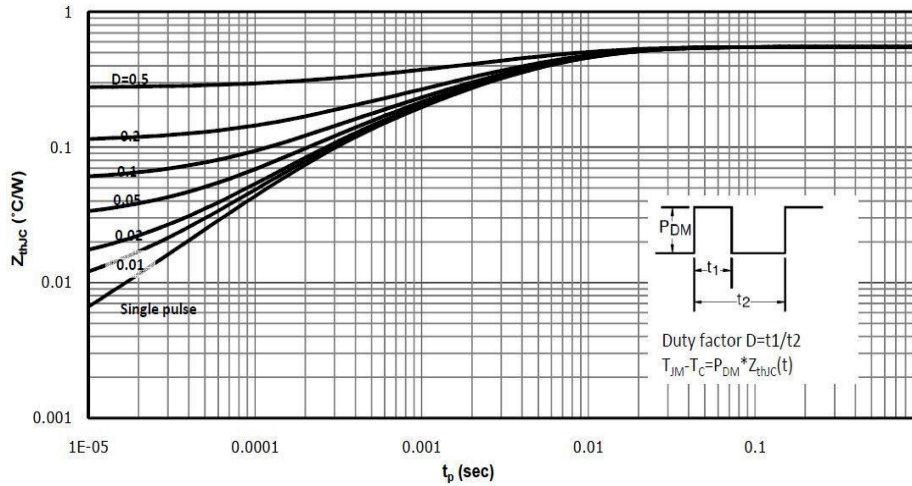

Figure 9. Normalized Maximum Transient Thermal Impedance (R<sub>thJC</sub>)



**Test Circuit & Waveform**

Figure 8. Gate Charge Test Circuit & Waveform

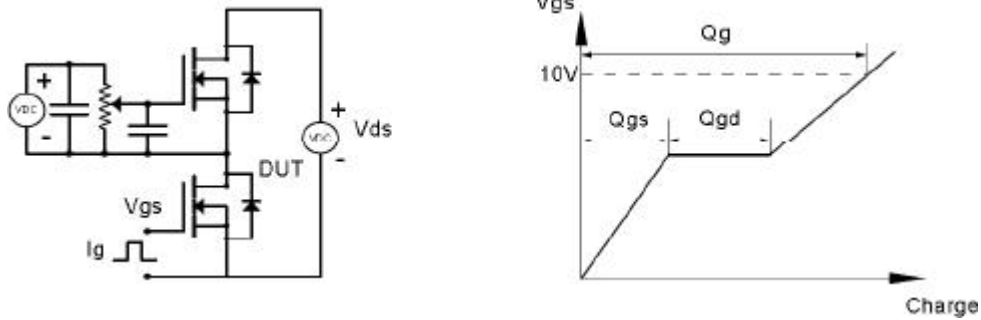

Figure 9. Resistive Switching Test Circuit & Waveforms

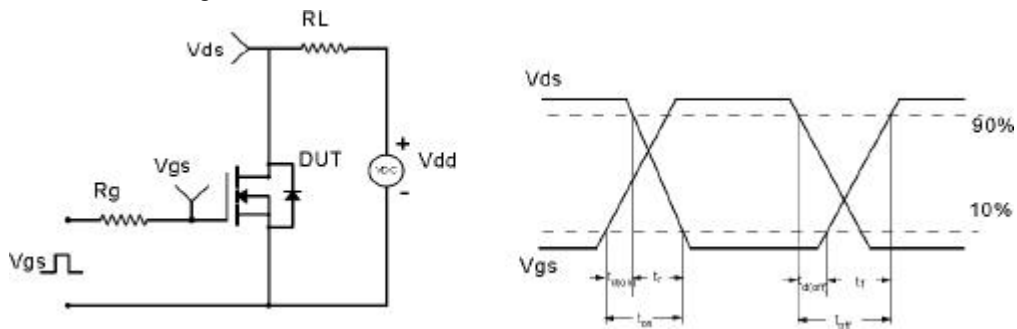

Figure 10. Unclamped Inductive Switching (UIS) Test Circuit & Waveform

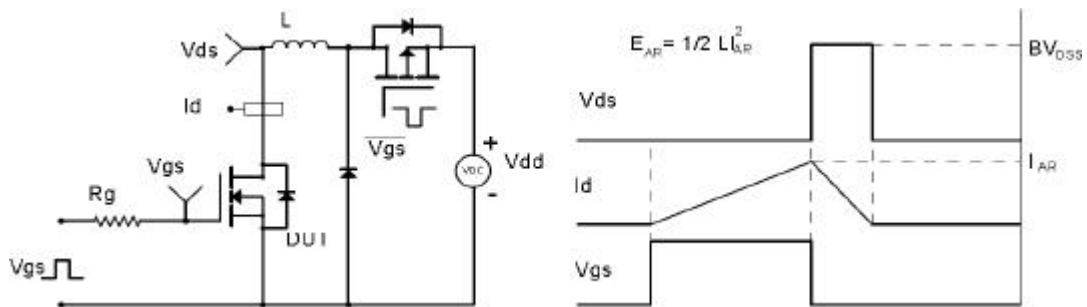
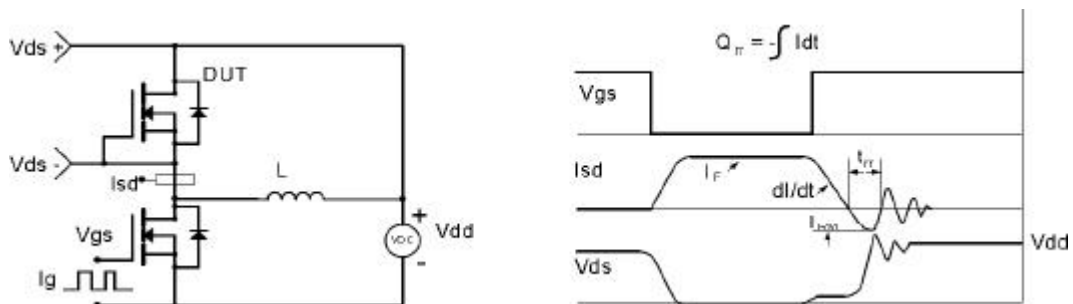
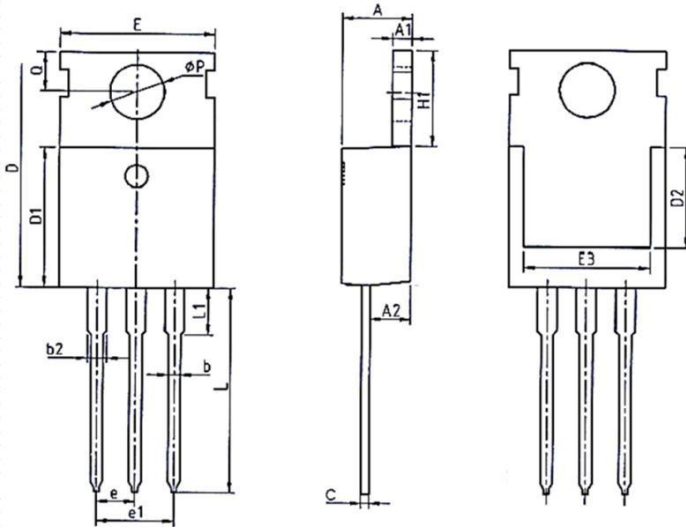

Figure 11. Diode Recovery Circuit & Waveform



**Mechanical Dimensions for TO-220**



| COMMON DIMENSIONS |         |       |       |        |       |       |
|-------------------|---------|-------|-------|--------|-------|-------|
| SYMBOL            | MM      |       |       | INCH   |       |       |
|                   | MIN     | NOM   | MAX   | MIN    | NOM   | MAX   |
| A                 | 4.37    | 4.57  | 4.70  | 0.172  | 0.180 | 0.185 |
| A1                | 1.25    | 1.30  | 1.40  | 0.049  | 0.051 | 0.055 |
| A2                | 2.20    | 2.40  | 2.60  | 0.087  | 0.094 | 0.102 |
| b                 | 0.70    | 0.80  | 0.95  | 0.028  | 0.031 | 0.037 |
| b2                | 1.17    | 1.27  | 1.47  | 0.046  | 0.050 | 0.058 |
| c                 | 0.45    | 0.50  | 0.60  | 0.018  | 0.020 | 0.024 |
| D                 | 15.10   | 15.60 | 16.10 | 0.594  | 0.614 | 0.634 |
| D1                | 8.80    | 9.10  | 9.40  | 0.346  | 0.358 | 0.370 |
| D2                | 5.50    | -     | -     | 0.217  | -     | -     |
| E                 | 9.70    | 10.00 | 10.30 | 0.382  | 0.394 | 0.406 |
| E3                | 7.00    | -     | -     | 0.276  | -     | -     |
| e                 | 2.54BCS |       |       | 0.1BSC |       |       |
| e1                | 5.08BCS |       |       | 0.2REF |       |       |
| H1                | 6.25    | 6.50  | 6.85  | 0.246  | 0.256 | 0.270 |
| L                 | 12.75   | 13.50 | 13.80 | 0.502  | 0.531 | 0.543 |
| L1                | -       | 3.10  | 3.40  | -      | 0.122 | 0.134 |
| ØP                | 3.40    | 3.60  | 3.80  | 0.134  | 0.142 | 0.150 |
| Q                 | 2.60    | 2.80  | 3.00  | 0.102  | 0.110 | 0.118 |

**TO-220 Part Marking Information**

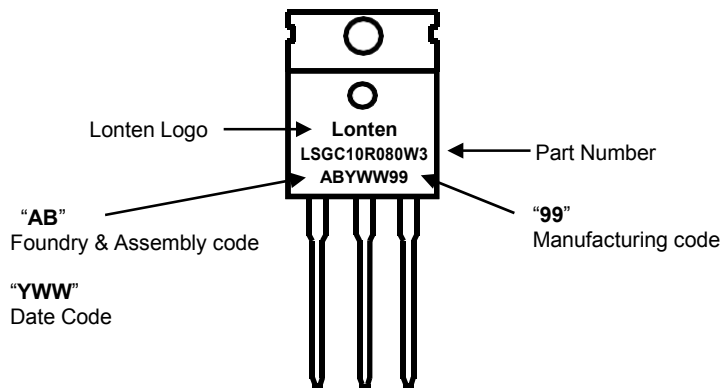

**Mechanical Dimensions for TO-220MF**

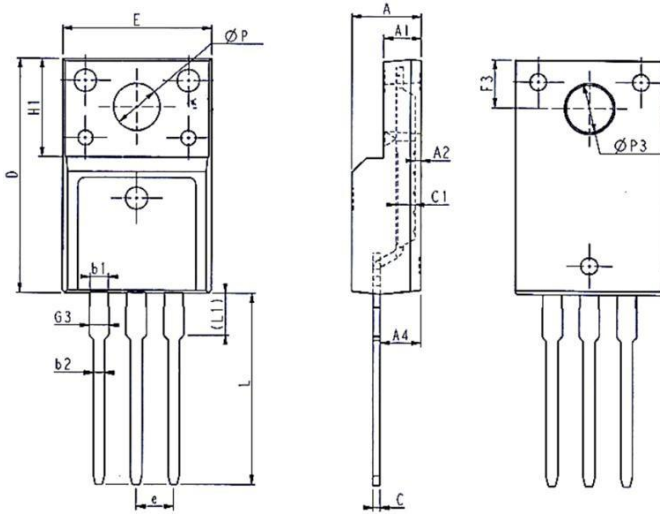

| COMMON DIMENSIONS |         |       |       |          |       |       |
|-------------------|---------|-------|-------|----------|-------|-------|
| SYMBOL            | MM      |       |       | INCH     |       |       |
|                   | MIN     | NOM   | MAX   | MIN      | NOM   | MAX   |
| E                 | 9.96    | 10.16 | 10.36 | 0.392    | 0.400 | 0.408 |
| A                 | 4.50    | 4.70  | 4.90  | 0.177    | 0.185 | 0.193 |
| A1                | 2.34    | 2.54  | 2.74  | 0.092    | 0.100 | 0.108 |
| A2                | 0.30    | 0.45  | 0.60  | 0.012    | 0.018 | 0.024 |
| A4                | 2.56    | 2.76  | 2.96  | 0.101    | 0.109 | 0.117 |
| c                 | 0.40    | 0.50  | 0.65  | 0.016    | 0.020 | 0.026 |
| c1                | 1.20    | 1.30  | 1.35  | 0.047    | 0.051 | 0.053 |
| D                 | 15.57   | 15.87 | 16.17 | 0.613    | 0.625 | 0.637 |
| H1                | 6.70REF |       |       | 0.264REF |       |       |
| e                 | 2.54BSC |       |       | 0.1BSC   |       |       |
| L                 | 12.68   | 12.98 | 13.28 | 0.499    | 0.511 | 0.523 |
| L1                | 2.88    | 3.03  | 3.18  | 0.113    | 0.119 | 0.125 |
| ØP                | 3.03    | 3.18  | 3.38  | 0.119    | 0.125 | 0.133 |
| ØP3               | 3.15    | 3.45  | 3.65  | 0.124    | 0.136 | 0.144 |
| F3                | 3.15    | 3.30  | 3.45  | 0.124    | 0.130 | 0.136 |
| G3                | 1.25    | 1.35  | 1.55  | 0.049    | 0.053 | 0.061 |
| b1                | 1.18    | 1.28  | 1.43  | 0.046    | 0.050 | 0.056 |
| b2                | 0.70    | 0.80  | 0.95  | 0.028    | 0.031 | 0.037 |

**TO-220MF Part Marking Information**

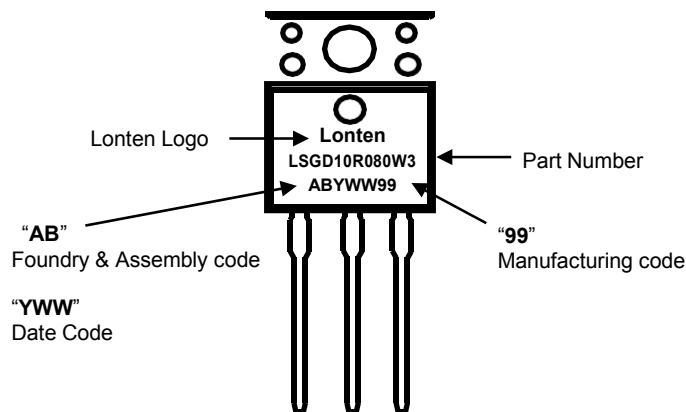

**TO-263 PACKAGE INFORMATION**

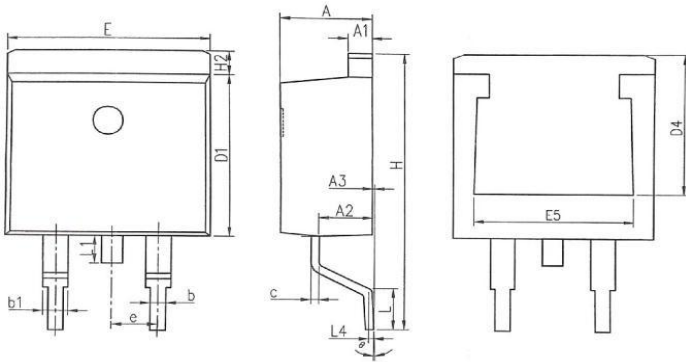

| COMMON DIMENSIONS |          |       |       |           |       |       |
|-------------------|----------|-------|-------|-----------|-------|-------|
| SYMBOL            | MM       |       |       | INCH      |       |       |
|                   | MIN      | NOM   | MAX   | MIN       | NOM   | MAX   |
| A                 | 4.37     | 4.57  | 4.77  | 0.172     | 0.180 | 0.188 |
| A1                | 1.22     | 1.27  | 1.42  | 0.048     | 0.050 | 0.056 |
| A2                | 2.49     | 2.69  | 2.89  | 0.098     | 0.106 | 0.114 |
| A3                | 0.00     | 0.13  | 0.25  | 0.000     | 0.005 | 0.010 |
| b                 | 0.70     | 0.81  | 0.96  | 0.028     | 0.032 | 0.038 |
| b1                | 1.17     | 1.27  | 1.47  | 0.046     | 0.050 | 0.058 |
| c                 | 0.30     | 0.38  | 0.53  | 0.012     | 0.015 | 0.021 |
| D1                | 8.50     | 8.70  | 8.90  | 0.335     | 0.343 | 0.350 |
| D4                | 6.60     | —     | —     | 0.260     | —     | —     |
| E                 | 9.86     | 10.16 | 10.36 | 0.388     | 0.400 | 0.408 |
| E5                | 7.06     | —     | —     | 0.278     | —     | —     |
| e                 | 2.54 BSC |       |       | 0.100 BSC |       |       |
| H                 | 14.70    | 15.10 | 15.50 | 0.579     | 0.594 | 0.610 |
| H2                | 1.07     | 1.27  | 1.47  | 0.042     | 0.050 | 0.058 |
| L                 | 2.00     | 2.30  | 2.60  | 0.079     | 0.091 | 0.102 |
| L1                | 1.40     | 1.55  | 1.70  | 0.055     | 0.061 | 0.067 |
| L4                | 0.25 BSC |       |       | 0.010 BSC |       |       |
| θ                 | 0°       | 5°    | 9°    | 0°        | 5°    | 9°    |

**TO-263 Part Marking Information**

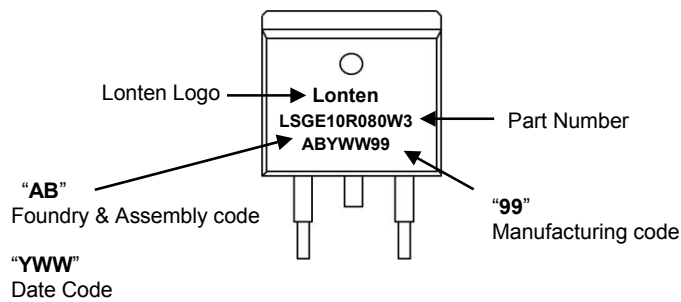



---

**Disclaimer**

The content specified herein is for the purpose of introducing LONTEN's products (hereinafter "Products"). The information given in this document shall in no event be regarded as a guarantee of conditions or characteristics. Examples of application circuits, circuit constants and any other information contained herein illustrate the standard usage and operations of the Products. The peripheral conditions must be taken into account when designing circuits for mass production.

LONTEN does not assume any liability for infringement of patents, copyrights, or other intellectual property rights of third parties by or arising from the use of the Products or technical information described in this document.

The Products are not designed or manufactured to be used with any equipment, device or system which requires an extremely high level of reliability the failure or malfunction of which may result in a direct threat to human life or create a risk of human injury (such as a medical instrument, transportation equipment, aerospace machinery, nuclear-reactor controller, fuel-controller or other safety device). LONTEN shall bear no responsibility in any way for use of any of the Products for the above special purposes.

Although LONTEN endeavors to improve the quality and reliability of its products, semiconductor products have specific characteristics such as the occurrence of failure at a certain rate and malfunctions under certain use conditions. Please be sure to implement safety measures to guard them against the possibility of physical injury, and injury or damage caused by fire in the event of the failure of a LONTEN product.

The content specified herein is subject to change for improvement without notice. When using a LONTEN product, be sure to obtain the latest specifications.

## X-ON Electronics

Largest Supplier of Electrical and Electronic Components

*Click to view similar products for [MOSFET](#) category:*

*Click to view products by [LONTEN](#) manufacturer:*

Other Similar products are found below :

[614233C](#) [648584F](#) [MCH3443-TL-E](#) [MCH6422-TL-E](#) [FDPF9N50NZ](#) [FW216A-TL-2W](#) [FW231A-TL-E](#) [APT5010JVR](#) [NTNS3A92PZT5G](#)  
[IRF100S201](#) [JANTX2N5237](#) [2SK2464-TL-E](#) [2SK3818-DL-E](#) [FCA20N60\\_F109](#) [FDZ595PZ](#) [STD6600NT4G](#) [FSS804-TL-E](#) [2SJ277-DL-E](#)  
[2SK1691-DL-E](#) [2SK2545\(Q,T\)](#) [D2294UK](#) [405094E](#) [423220D](#) [MCH6646-TL-E](#) [TPCC8103,L1Q\(CM](#) [367-8430-0972-503](#) [VN1206L](#)  
[424134F](#) [026935X](#) [051075F](#) [SBVS138LT1G](#) [614234A](#) [715780A](#) [NTNS3166NZT5G](#) [751625C](#) [873612G](#) [IRF7380TRHR](#)  
[IPS70R2K0CEAKMA1](#) [RJK60S3DPP-E0#T2](#) [RJK60S5DPK-M0#T0](#) [APT5010JVFR](#) [APT12031JFLL](#) [APT12040JVR](#) [DMN3404LQ-7](#)  
[NTE6400](#) [JANTX2N6796U](#) [JANTX2N6784U](#) [JANTXV2N5416U4](#) [SQM110N05-06L-GE3](#) [SIHF35N60E-GE3](#)