

Lonten N-channel 40V, 120A, 3.5mΩ Power MOSFET

<p>Description</p> <p>These N-Channel enhancement mode power field effect transistors are using split gate trench DMOS technology. This advanced technology has been especially tailored to minimize on-state resistance, provide superior switching performance, and with stand high energy pulse in the avalanche and commutation mode. These devices are well suited for high efficiency fast switching applications.</p> <p>Features</p> <p>40V,120A, $R_{DS(on),max} = 3.5m\Omega @ V_{GS} = 10V$</p> <p>Improved dv/dt capability</p> <p>Fast switching</p> <ul style="list-style-type: none"> ◆ 100% EAS Guaranteed ◆ Green device available <p>Applications</p> <ul style="list-style-type: none"> ◆ Motor Drives ◆ UPS ◆ DC-DC Converter 	<p>Product Summary</p> <p>V_{DSS} 40V</p> <p>$R_{DS(on),max} @ V_{GS}=10V$ 3.5mΩ</p> <p>I_D 120A</p> <p>Pin Configuration</p> <p>TO-220 TO-220MF TO-251</p> <p>DFN5×6 TO-252,TO-263</p> <p>N-Channel MOSFET</p>
--	--

Absolute Maximum Ratings $T_C = 25^\circ C$ unless otherwise noted

Parameter	Symbol	Value	Unit
Drain-Source Voltage	V_{DSS}	40	V
Continuous drain current ($T_C = 25^\circ C$) ¹⁾	I_D	120	A
Continuous drain current ($T_C = 100^\circ C$) ¹⁾		113	A
Pulsed drain current ²⁾	I_{DM}	360	A
Gate-Source voltage	V_{GSS}	± 20	V
Avalanche energy ³⁾	E_{AS}	156	mJ
Power Dissipation ($T_C = 25^\circ C$) TO-220/TO-263/DFN5×6	P_D	85.8	W
Power Dissipation ($T_C = 25^\circ C$) TO-220MF		52	W
Storage Temperature Range	T_{STG}	-55 to +150	$^\circ C$
Operating Junction Temperature Range	T_J	-55 to +150	$^\circ C$

Thermal Characteristics

Parameter	Symbol	Value	Unit
Thermal Resistance, Junction-to-Case TO-220/TO-263/TO-252/DFN5×6	$R_{\theta JC}$	1.46	$^\circ C/W$
Thermal Resistance, Junction-to-Case TO-220MF		2.4	$^\circ C/W$
Thermal Resistance, Junction-to-Ambient TO-220/TO-263/TO-252/DFN5×6	$R_{\theta JA}$	65	$^\circ C/W$
Thermal Resistance, Junction-to-Case TO-220MF		85	$^\circ C/W$

Package Marking and Ordering Information

Device	Device Package	Marking
LSGC04R035	TO-220	LSGC04R035
LSGD04R035	TO-220MF	LSGD04R035
LSGE04R035	TO-263	LSGE04R035
LSGG04R035	TO-252	LSGG04R035
LSGH04R035	TO-251	LSGH04R035
LSGN04R035	DFN5×6	LSGN04R035

Electrical Characteristics
 $T_J = 25^\circ\text{C}$ unless otherwise noted

Parameter	Symbol	Test Condition	Min.	Typ.	Max.	Unit
Static characteristics						
Drain-source breakdown voltage	BV_{DSS}	$V_{GS}=0\text{ V}, I_D=250\mu\text{A}$	40	---	---	V
Gate threshold voltage	$V_{GS(th)}$	$V_{DS}=V_{GS}, I_D=250\mu\text{A}$	1.0	---	2.5	V
Drain-source leakage current	I_{DSS}	$V_{DS}=40\text{ V}, V_{GS}=0\text{ V}, T_J = 25^\circ\text{C}$	---	---	1	μA
Gate leakage current, Forward	I_{GSSF}	$V_{GS}=20\text{ V}, V_{DS}=0\text{ V}$	---	---	100	nA
Gate leakage current, Reverse	I_{GSSR}	$V_{GS}=-20\text{ V}, V_{DS}=0\text{ V}$	---	---	-100	nA
Drain-source on-state resistance	$R_{DS(on)}$	$V_{GS}=10\text{ V}, I_D=30\text{ A}$	---	---	3.5	m Ω
Forward transconductance	g_{fs}	$V_{DS}=10\text{ V}, I_D=20\text{ A}$	---	40	---	S
Dynamic characteristics						
Input capacitance	C_{iss}	$V_{DS} = 20\text{ V}, V_{GS} = 0\text{ V},$ $F = 1\text{ MHz}$	---	2100	2700	pF
Output capacitance	C_{oss}		---	639	850	
Reverse transfer capacitance	C_{rss}		---	23.6	30	
Turn-on delay time	$t_{d(on)}$	$V_{DD} = 20\text{ V}, V_{GS}=10\text{ V}, I_D = 20\text{ A}$ $R_G=1.6\Omega$	---	8	---	ns
Rise time	t_r		---	4.5	---	
Turn-off delay time	$t_{d(off)}$		---	28	---	
Fall time	t_f		---	3.5	---	
Gate charge characteristics						
Gate to source charge	Q_{gs}	$V_{DS}=20\text{ V}, I_D=20\text{ A},$ $V_{GS}=10\text{ V}$	---	6.5	---	nC
Gate to drain charge	Q_{gd}		---	4.8	---	
Gate charge total	Q_g		---	33.8	---	
Drain-Source diode characteristics and Maximum Ratings						
Continuous Source Current	I_S		---	---	120	A
Pulsed Source Current ⁴⁾	I_{SM}		---	---	360	A
Diode Forward Voltage	V_{SD}	$V_{GS}=0\text{ V}, I_S=45\text{ A}, T_J=25^\circ\text{C}$	---	0.9	1.2	V
Reverse Recovery Time	t_{rr}	$I_S=I_F, di/dt=500\text{ A}/\mu\text{s}, T_J=25^\circ\text{C}$	---	19	---	ns
Reverse Recovery Charge	Q_{rr}	⁵⁾	---	40	---	nC

Notes:

- 1: The maximum junction current rating is package limited.
- 2: Repetitive Rating: Pulse width limited by maximum junction temperature.
- 3: $V_{DD}=20\text{ V}, V_{GS}=10\text{ V}, L=0.5\text{ mH}, I_{AS}=25\text{ A}, R_G=25\Omega$, Starting $T_J=25^\circ\text{C}$.
- 4: Pulse Test: Pulse Width $\leq 300\ \mu\text{s}$, Duty Cycle $\leq 2\%$.
- 5: Guaranteed by design, not subject to production.

Electrical Characteristics Diagrams

Figure 1. Typ. Output Characteristics

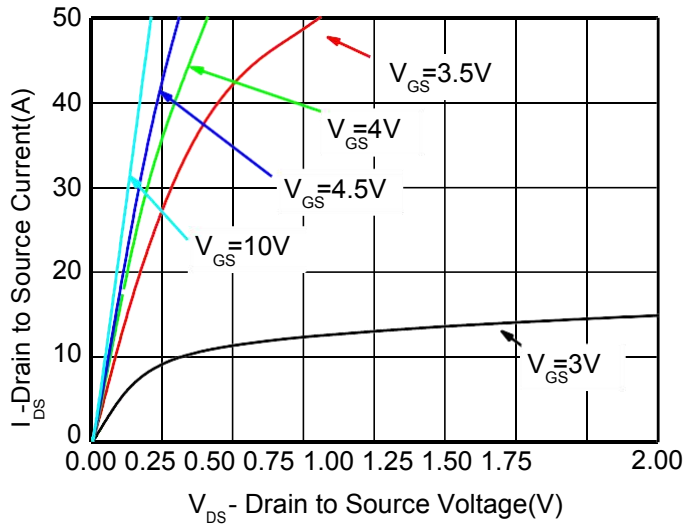

Figure 2. Transfer Characteristics

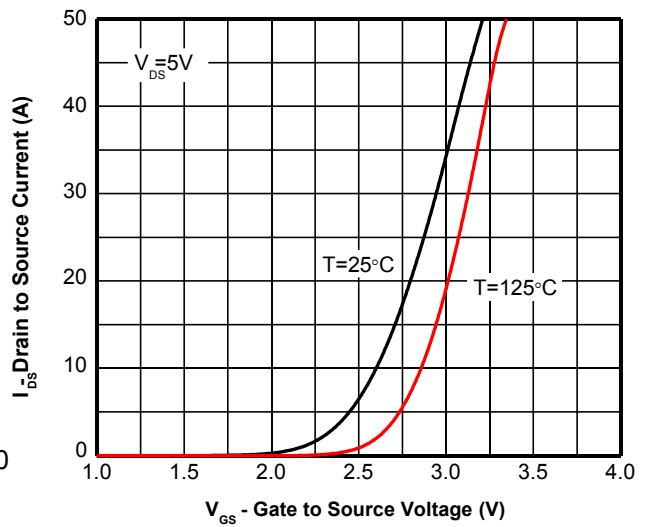

Figure 3. Capacitance Characteristics

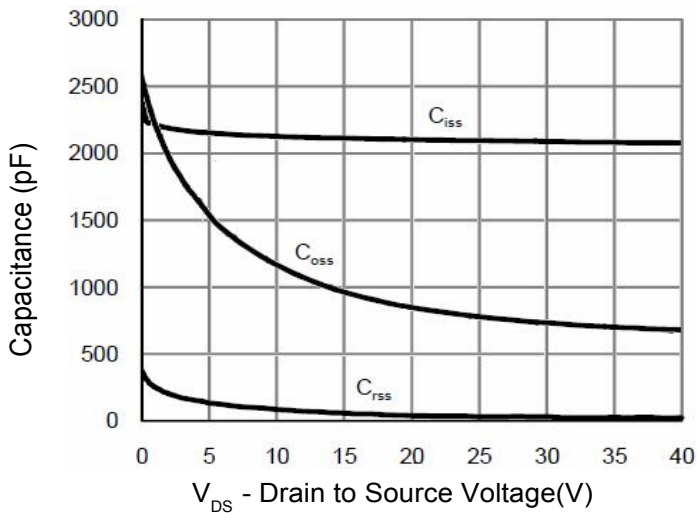

Figure 4. Gate Charge Waveform

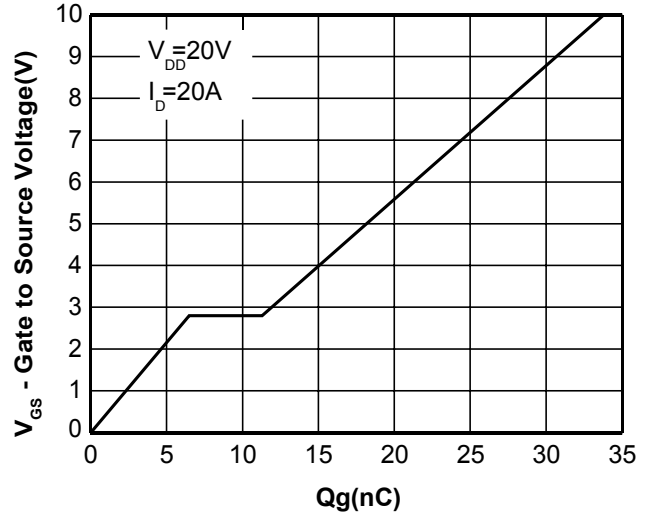

Figure 5. Body-Diode Characteristics

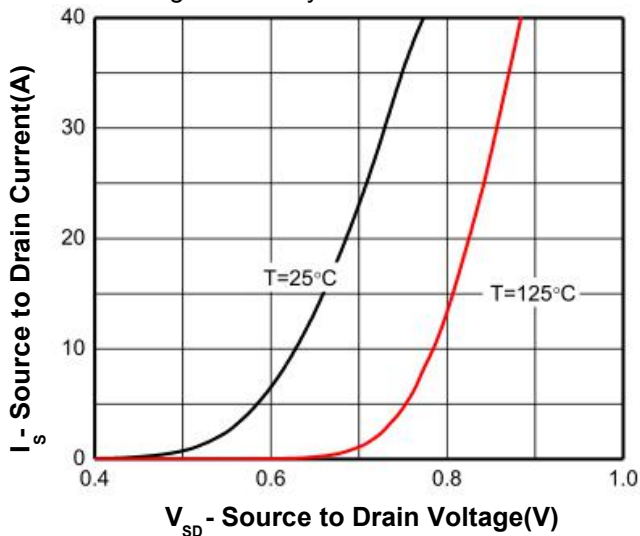

Figure 6. Rds(on)-Drain Current

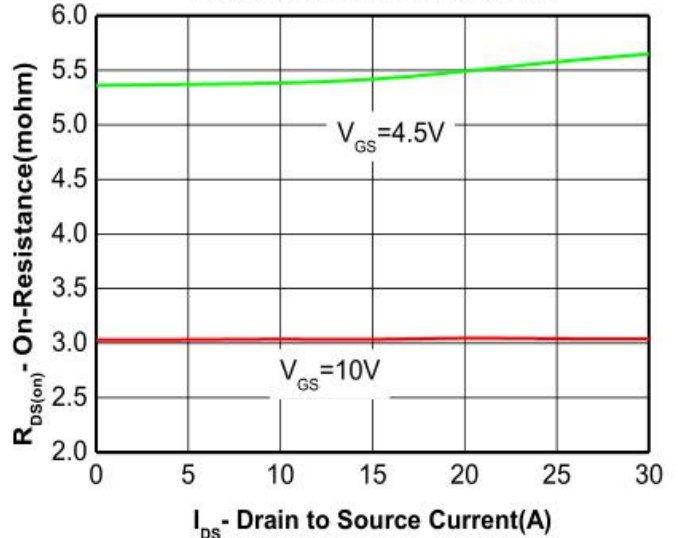

Figure 7. R_{ds(on)}-Junction Temperature(°C)

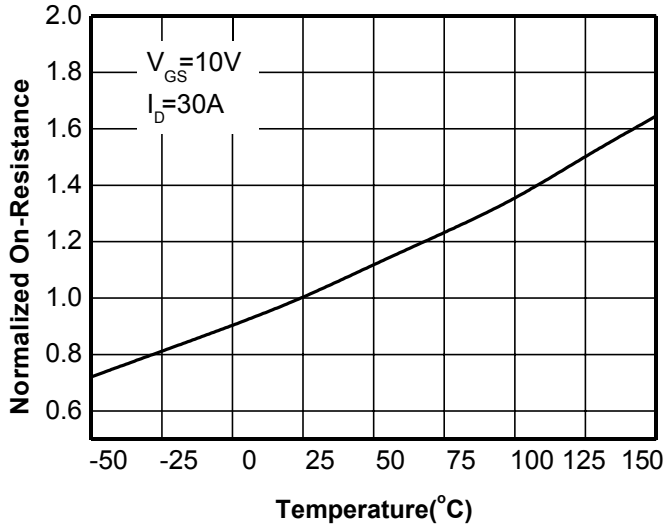

Figure 9. On-Resistance vs. Gate-to-Source voltage

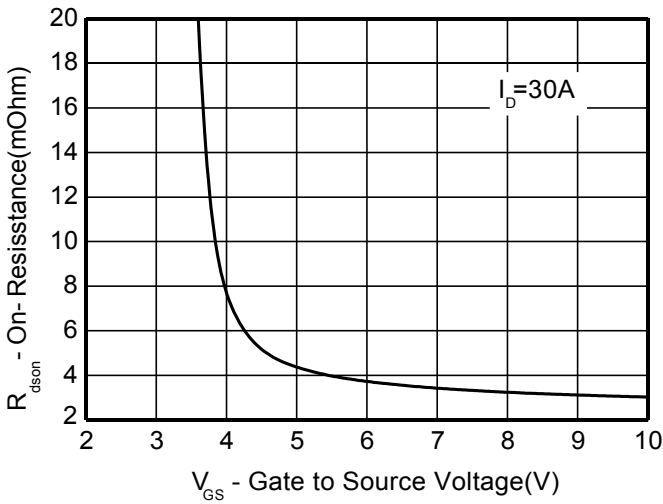

Figure 8. Maximum Safe Operating Area

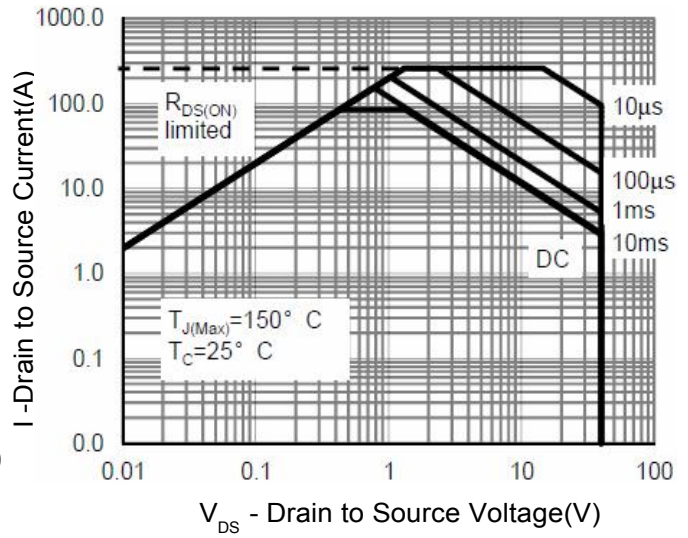

Figure 10. B_{Vdss} vs. Junction temperature

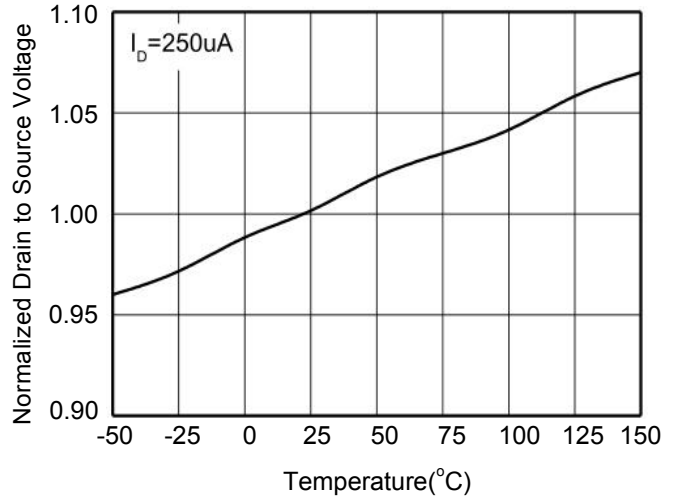
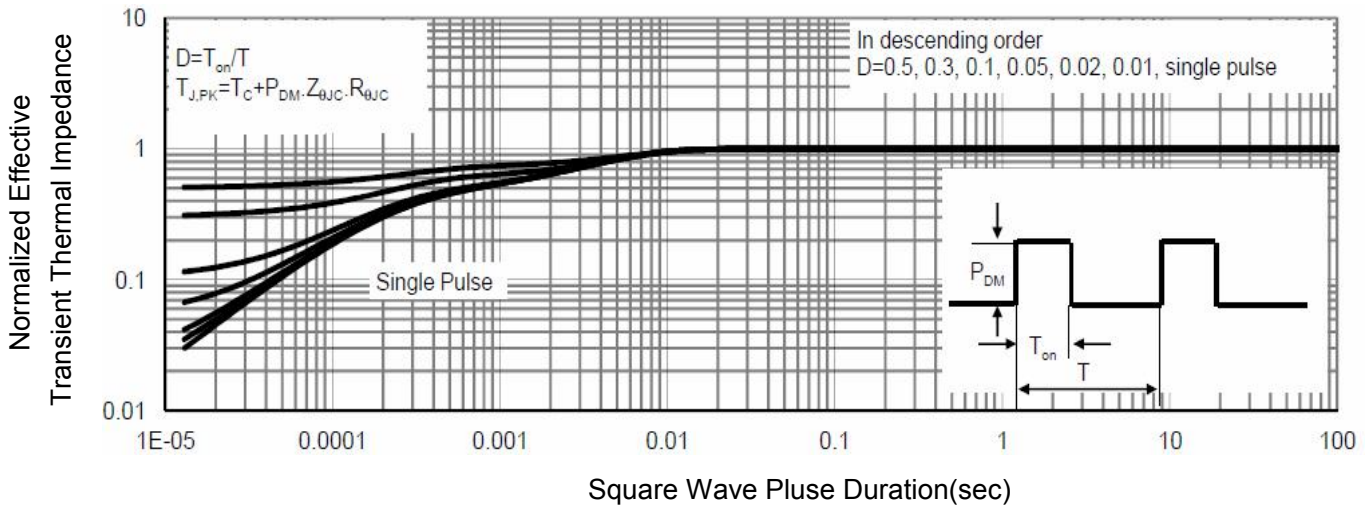

Figure 11. Normalized Maximum Transient Thermal Impedance (R_{thJC})



Test Circuit & Waveform

Figure 12. Gate Charge Test Circuit & Waveform

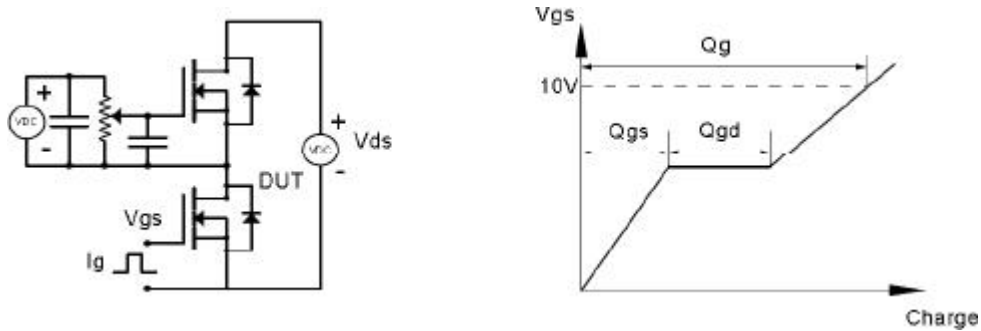

Figure 13. Resistive Switching Test Circuit & Waveforms

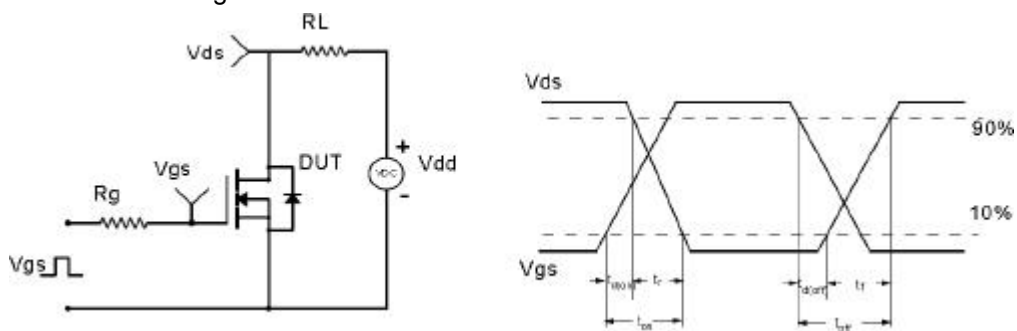

Figure 14. Unclamped Inductive Switching (UIS) Test Circuit & Waveform

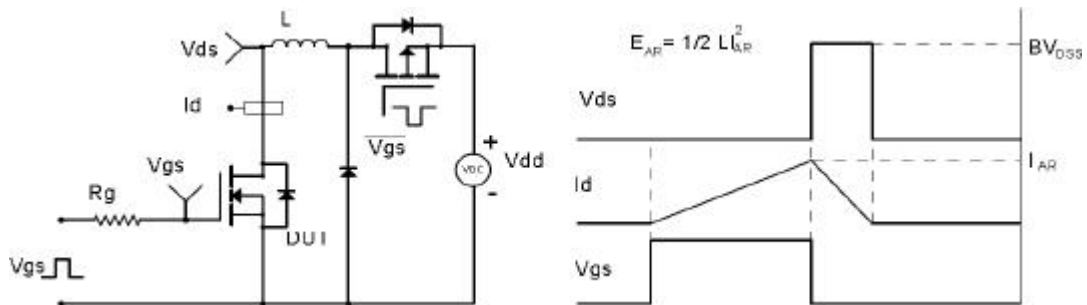
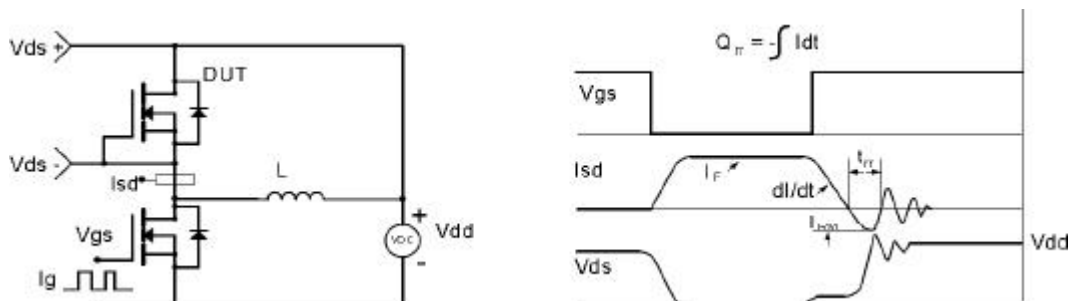
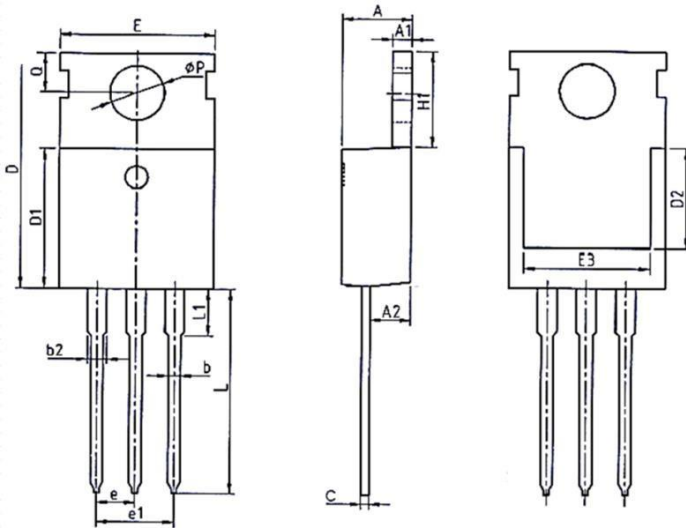

Figure 15. Diode Recovery Circuit & Waveform



Mechanical Dimensions for TO-220



SYMBOL	COMMON DIMENSIONS					
	MM			INCH		
	MIN	NOM	MAX	MIN	NOM	MAX
A	4.37	4.57	4.70	0.172	0.180	0.185
A1	1.25	1.30	1.40	0.049	0.051	0.055
A2	2.20	2.40	2.60	0.087	0.094	0.102
b	0.70	0.80	0.95	0.028	0.031	0.037
b2	1.17	1.27	1.47	0.046	0.050	0.058
c	0.45	0.50	0.60	0.018	0.020	0.024
D	15.10	15.60	16.10	0.594	0.614	0.634
D1	8.80	9.10	9.40	0.346	0.358	0.370
D2	5.50	-	-	0.217	-	-
E	9.70	10.00	10.30	0.382	0.394	0.406
E3	7.00	-	-	0.276	-	-
e	2.54BCS			0.1BSC		
e1	5.08BCS			0.2REF		
H1	6.25	6.50	6.85	0.246	0.256	0.270
L	12.75	13.50	13.80	0.502	0.531	0.543
L1	-	3.10	3.40	-	0.122	0.134
ØP	3.40	3.60	3.80	0.134	0.142	0.150
Q	2.60	2.80	3.00	0.102	0.110	0.118

TO-220 Part Marking Information

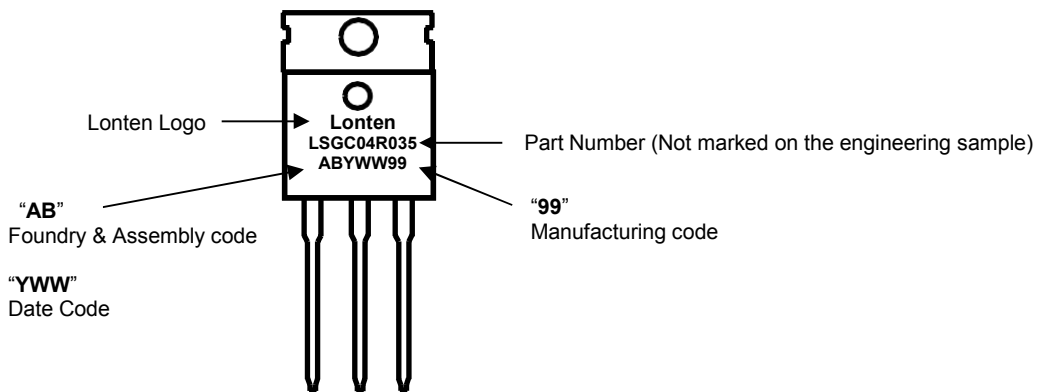

Calendar Year	Year Code	Calendar Week	Week Code
2018	G	Workweek 01	01
2019	H	Workweek 02	02
2020	I	Workweek 03	03
2021	J	Workweek 04	04
2022	K	Workweek 05	05
2023	L	Workweek 06	06
2024	M

Mechanical Dimensions for TO-220MF

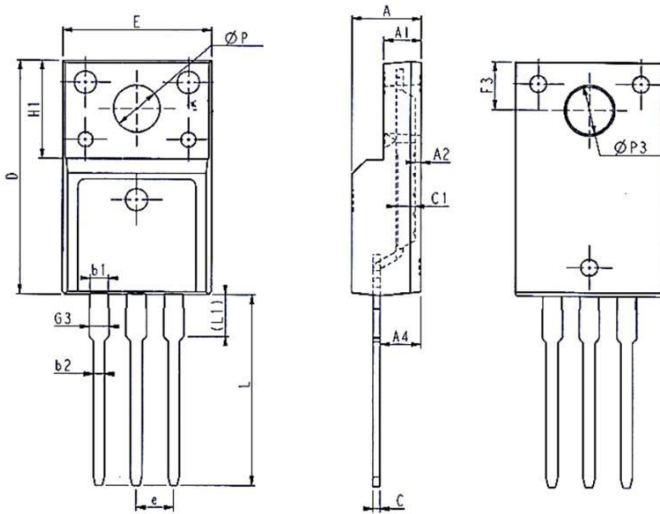

COMMON DIMENSIONS						
SYMBOL	MM			INCH		
	MIN	NOM	MAX	MIN	NOM	MAX
E	9.96	10.16	10.36	0.392	0.400	0.408
A	4.50	4.70	4.90	0.177	0.185	0.193
A1	2.34	2.54	2.74	0.092	0.100	0.108
A2	0.30	0.45	0.60	0.012	0.018	0.024
A4	2.56	2.76	2.96	0.101	0.109	0.117
c	0.40	0.50	0.65	0.016	0.020	0.026
c1	1.20	1.30	1.35	0.047	0.051	0.053
D	15.57	15.87	16.17	0.613	0.625	0.637
H1	6.70REF			0.264REF		
e	2.54BSC			0.1BSC		
L	12.68	12.98	13.28	0.499	0.511	0.523
L1	2.88	3.03	3.18	0.113	0.119	0.125
ØP	3.03	3.18	3.38	0.119	0.125	0.133
ØP3	3.15	3.45	3.65	0.124	0.136	0.144
F3	3.15	3.30	3.45	0.124	0.130	0.136
G3	1.25	1.35	1.55	0.049	0.053	0.061
b1	1.18	1.28	1.43	0.046	0.050	0.056
b2	0.70	0.80	0.95	0.028	0.031	0.037

TO-220MF Part Marking Information

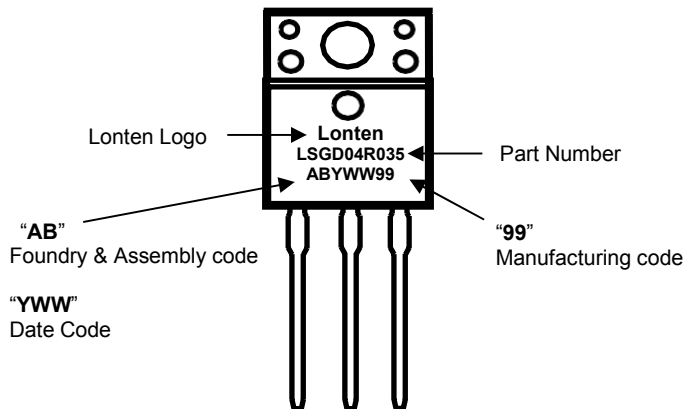

Calendar Year	Year Code	Calendar Week	Week Code
2018	G	Workweek 01	01
2019	H	Workweek 02	02
2020	I	Workweek 03	03
2021	J	Workweek 04	04
2022	K	Workweek 05	05
2023	L	Workweek 06	06
2024	M

TO-263 PACKAGE INFORMATION

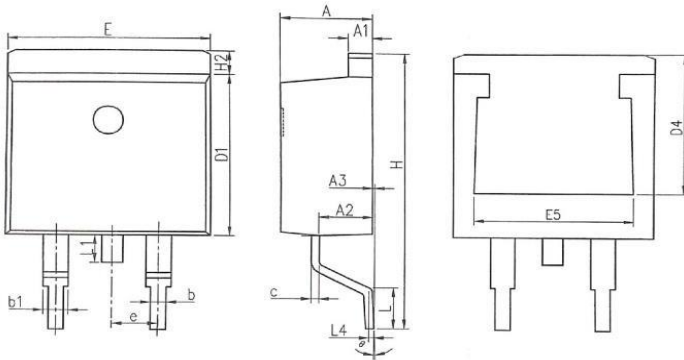

SYMBOL	COMMON DIMENSIONS					
	MM			INCH		
	MIN	NOM	MAX	MIN	NOM	MAX
A	4.37	4.57	4.77	0.172	0.180	0.188
A1	1.22	1.27	1.42	0.048	0.050	0.056
A2	2.49	2.69	2.89	0.098	0.106	0.114
A3	0.00	0.13	0.25	0.000	0.005	0.010
b	0.70	0.81	0.96	0.028	0.032	0.038
b1	1.17	1.27	1.47	0.046	0.050	0.058
c	0.30	0.38	0.53	0.012	0.015	0.021
D1	8.50	8.70	8.90	0.335	0.343	0.350
D4	6.60	—	—	0.260	—	—
E	9.86	10.16	10.36	0.388	0.400	0.408
E5	7.06	—	—	0.278	—	—
e	2.54 BSC			0.100 BSC		
H	14.70	15.10	15.50	0.579	0.594	0.610
H2	1.07	1.27	1.47	0.042	0.050	0.058
L	2.00	2.30	2.60	0.079	0.091	0.102
L1	1.40	1.55	1.70	0.055	0.061	0.067
L4	0.25 BSC			0.010 BSC		
θ	0°	5°	9°	0°	5°	9°

TO-263 Part Marking Information

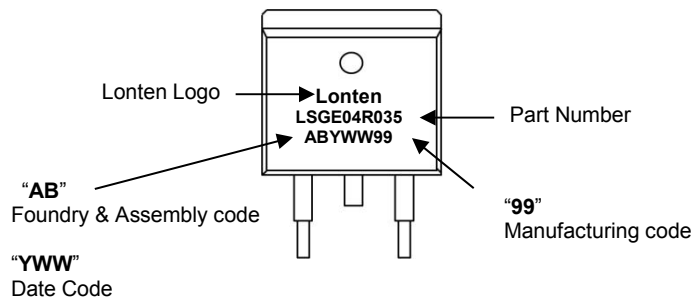

Calendar Year	Year Code	Calendar Week	Week Code
2018	G	Workweek 01	01
2019	H	Workweek 02	02
2020	I	Workweek 03	03
2021	J	Workweek 04	04
2022	K	Workweek 05	05
2023	L	Workweek 06	06
2024	M

Mechanical Dimensions for TO-252

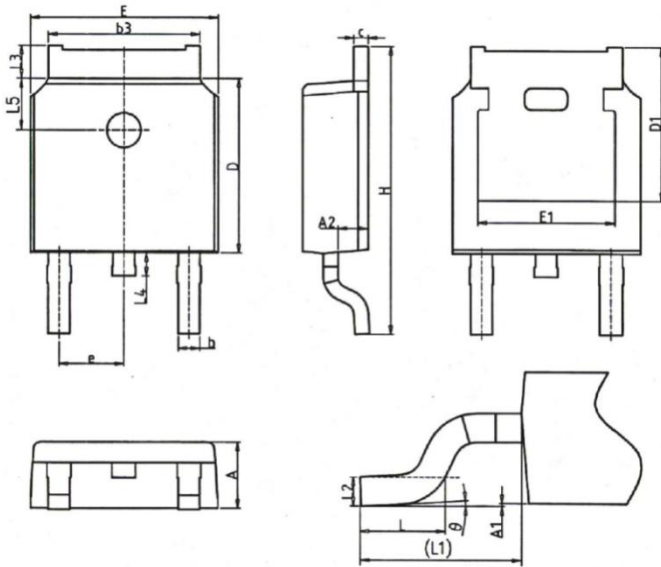

SYMBOL	COMMON DIMENSIONS					
	MM			INCH		
	MIN	NOM	MAX	MIN	NOM	MAX
A	2.20	2.30	2.38	0.087	0.091	0.094
A1	0.00	-	0.20	0.000	-	0.008
A2	0.97	1.07	1.17	0.038	0.042	0.046
b	0.68	0.78	0.90	0.027	0.031	0.035
b3	5.20	5.33	5.46	0.205	0.210	0.215
c	0.43	0.53	0.61	0.017	0.021	0.024
D	5.98	6.10	6.22	0.235	0.240	0.245
D1	5.30REF			0.209REF		
E	6.40	6.60	6.73	0.252	0.260	0.265
E1	4.63	-	-	0.182	-	-
e	2.286BSC			0.090BSC		
H	9.40	10.10	10.50	0.370	0.398	0.413
L	1.38	1.50	1.75	0.054	0.059	0.069
L1	2.90REF			0.114REF		
L2	0.51BSC			0.020BSC		
L3	0.88	-	1.28	0.035	-	0.050
L4	0.50	-	1.00	0.020	-	0.039
L5	1.65	1.80	1.95	0.065	0.071	0.077
θ	0°	-	8°	0°	-	8°

TO-252 Part Marking Information

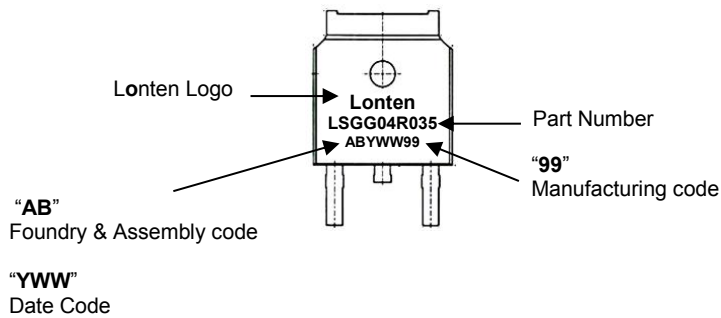

Calendar Year	Year Code	Calendar Week	Week Code
2018	G	Workweek 01	01
2019	H	Workweek 02	02
2020	I	Workweek 03	03
2021	J	Workweek 04	04
2022	K	Workweek 05	05
2023	L	Workweek 06	06
2024	M

Mechanical Dimensions for TO-251

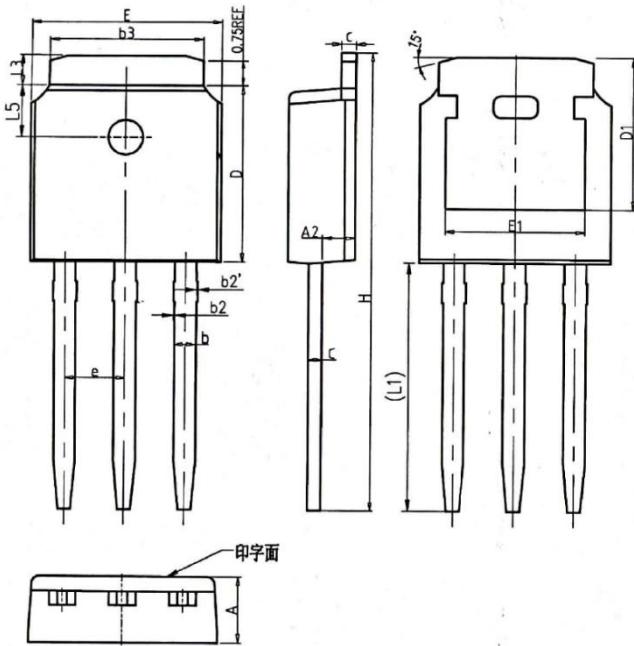

COMMON DIMENSIONS						
SYMBOL	MM			INCH		
	MIN	NOM	MAX	MIN	NOM	MAX
A	2.20	2.30	2.38	0.087	0.091	0.094
A2	0.97	1.07	1.17	0.038	0.042	0.046
b	0.68	0.78	0.90	0.027	0.031	0.035
b2	0.00	0.04	0.10	0.000	0.002	0.004
b2'	0.00	0.04	0.10	0.000	0.002	0.004
b3	5.20	5.33	5.46	0.205	0.210	0.215
c	0.43	0.53	0.61	0.017	0.021	0.024
D	5.98	6.10	6.22	0.235	0.240	0.245
D1	5.30REF			0.209REF		
E	6.40	6.60	6.73	0.252	0.260	0.265
E1	4.63	-	-	0.182	-	-
e	2.286BSC			0.090BSC		
H	16.22	16.52	16.82	0.639	0.650	0.662
L1	9.15	9.40	9.65	0.360	0.370	0.380
L3	0.88	1.02	1.28	0.035	0.040	0.050
L5	1.65	1.80	1.95	0.065	0.071	0.077

TO-251 Part Marking Information

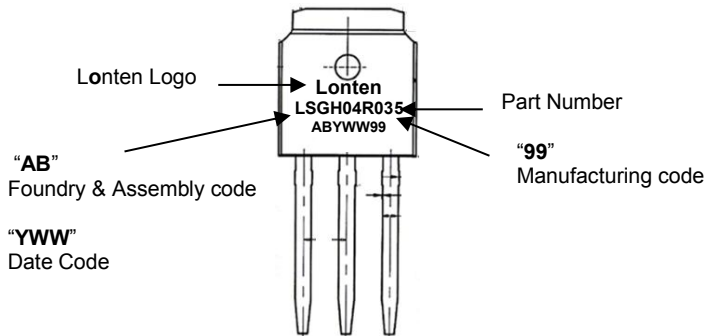

Calendar Year	Year Code	Calendar Week	Week Code
2018	G	Workweek 01	01
2019	H	Workweek 02	02
2020	I	Workweek 03	03
2021	J	Workweek 04	04
2022	K	Workweek 05	05
2023	L	Workweek 06	06
2024	M

Mechanical Dimensions for DFN5×6

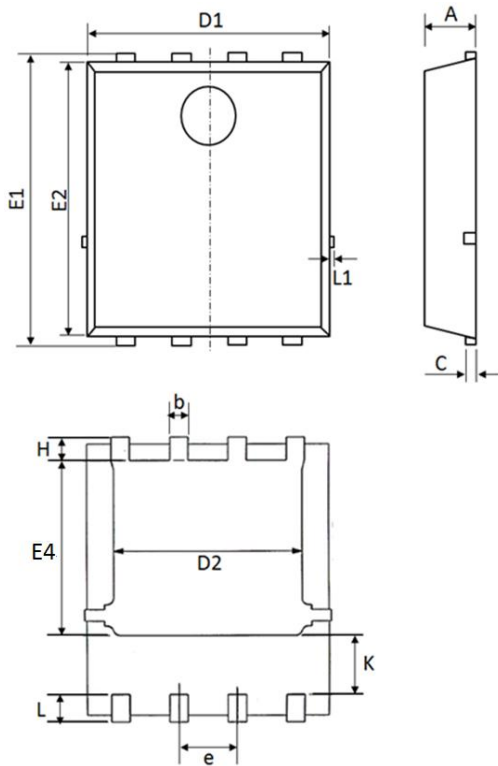

COMMON DIMENSIONS						
SYMBOL	MILLIMETERS			INCHS		
	MIN	NOM	MAX	MIN	NOM	MAX
A	1	1.1	1.2	0.039	0.043	0.047
b	0.3	0.4	0.5	0.012	0.016	0.020
C	0.154	0.254	0.354	0.006	0.010	0.014
D1	5	5.2	5.4	0.197	0.205	0.213
D2	3.8	4.1	4.25	0.150	0.161	0.167
E1	5.95	6.15	6.35	0.234	0.242	0.250
E2	5.66	5.86	6.06	0.223	0.231	0.239
E4	3.52	3.72	3.92	0.139	0.146	0.154
e	1.27 BSC			0.050 BSC		
H	0.4	0.5	0.6	0.016	0.020	0.024
L	0.5	0.6	0.7	0.020	0.024	0.028
L1	-	-	0.12	-	-	0.005
K	1.14	1.29	1.44	0.045	0.051	0.057

DFN5×6 Part Marking Information

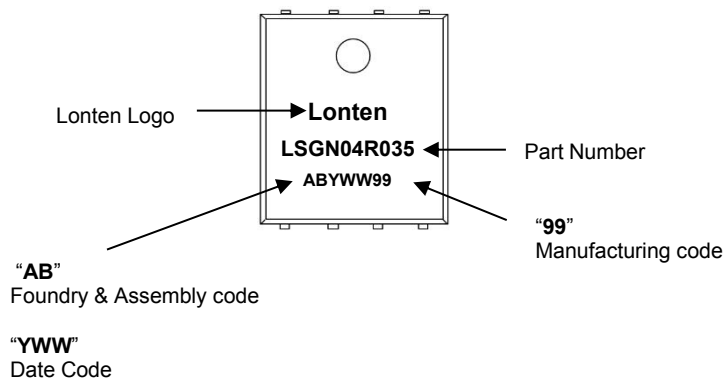

Calendar Year	Year Code	Calendar Week	Week Code
2018	G	Workweek 01	01
2019	H	Workweek 02	02
2020	I	Workweek 03	03
2021	J	Workweek 04	04
2022	K	Workweek 05	05
2023	L	Workweek 06	06
2024	M

Disclaimer

The content specified herein is for the purpose of introducing LONTEN's products (hereinafter "Products"). The information given in this document shall in no event be regarded as a guarantee of conditions or characteristics. Examples of application circuits, circuit constants and any other information contained herein illustrate the standard usage and operations of the Products. The peripheral conditions must be taken into account when designing circuits for mass production.

LONTEN does not assume any liability for infringement of patents, copyrights, or other intellectual property rights of third parties by or arising from the use of the Products or technical information described in this document.

The Products are not designed or manufactured to be used with any equipment, device or system which requires an extremely high level of reliability the failure or malfunction of which may result in a direct threat to human life or create a risk of human injury (such as a medical instrument, transportation equipment, aerospace machinery, nuclear-reactor controller, fuel-controller or other safety device). LONTEN shall bear no responsibility in any way for use of any of the Products for the above special purposes.

Although LONTEN endeavors to improve the quality and reliability of its products, semiconductor products have specific characteristics such as the occurrence of failure at a certain rate and malfunctions under certain use conditions. Please be sure to implement safety measures to guard them against the possibility of physical injury, and injury or damage caused by fire in the event of the failure of a LONTEN product.

The content specified herein is subject to change for improvement without notice. When using a LONTEN product, be sure to obtain the latest specifications.

X-ON Electronics

Largest Supplier of Electrical and Electronic Components

Click to view similar products for [MOSFET](#) category:

Click to view products by [LONTEN](#) manufacturer:

Other Similar products are found below :

[614233C](#) [648584F](#) [MCH3443-TL-E](#) [MCH6422-TL-E](#) [FDPF9N50NZ](#) [FW216A-TL-2W](#) [FW231A-TL-E](#) [APT5010JVR](#) [NTNS3A92PZT5G](#)
[IRF100S201](#) [JANTX2N5237](#) [2SK2464-TL-E](#) [2SK3818-DL-E](#) [FCA20N60_F109](#) [FDZ595PZ](#) [STD6600NT4G](#) [FSS804-TL-E](#) [2SJ277-DL-E](#)
[2SK1691-DL-E](#) [2SK2545\(Q,T\)](#) [D2294UK](#) [405094E](#) [423220D](#) [MCH6646-TL-E](#) [TPCC8103,L1Q\(CM](#) [367-8430-0972-503](#) [VN1206L](#)
[424134F](#) [026935X](#) [051075F](#) [SBVS138LT1G](#) [614234A](#) [715780A](#) [NTNS3166NZT5G](#) [751625C](#) [873612G](#) [IRF7380TRHR](#)
[IPS70R2K0CEAKMA1](#) [RJK60S3DPP-E0#T2](#) [RJK60S5DPK-M0#T0](#) [APT5010JVFR](#) [APT12031JFLL](#) [APT12040JVR](#) [DMN3404LQ-7](#)
[NTE6400](#) [JANTX2N6796U](#) [JANTX2N6784U](#) [JANTXV2N5416U4](#) [SQM110N05-06L-GE3](#) [SIHF35N60E-GE3](#)