

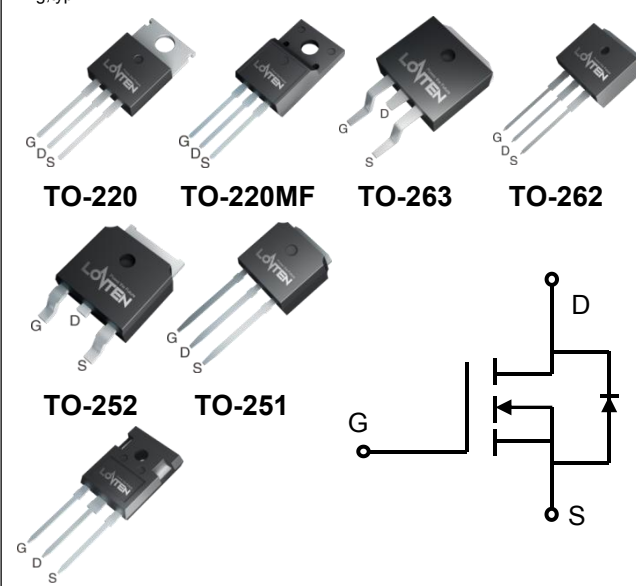

Lonten N-channel 800V, 8A, 0.68Ω LonFET™ Power MOSFET

<p>Description LonFET™ Power MOSFET is fabricated using advanced super junction technology. The resulting device has extremely low on resistance, making it especially suitable for applications which require superior power density and outstanding efficiency.</p> <p>Features</p> <ul style="list-style-type: none"> ◆ Ultra low $R_{DS(on)}$ ◆ Ultra low gate charge (typ. $Q_g = 19.5nC$) ◆ 100% UIS tested ◆ RoHS compliant <p>Applications</p> <ul style="list-style-type: none"> ◆ Power factor correction (PFC). ◆ Switched mode power supplies (SMPS). ◆ Uninterruptible power supply (UPS). 	<p>Product Summary</p> <p>$V_{DS} @ T_{j,max}$ 850V</p> <p>$R_{DS(on),max}$ 0.68Ω</p> <p>I_{DM} 8A</p> <p>$Q_{g,typ}$ 19.5nC</p>  <p style="text-align: center;">N-Channel MOSFET </p>
---	---

Absolute Maximum Ratings

Parameter	Symbol	Value	Unit
Drain-Source Voltage	V_{DSS}	800	V
Continuous drain current ($T_C = 25^\circ C$) ($T_C = 100^\circ C$)	I_D	8	A
		5	A
Pulsed drain current ¹⁾	I_{DM}	24	A
Gate-Source voltage	V_{GSS}	± 30	V
Avalanche energy, single pulse ²⁾	E_{AS}	235	mJ
Avalanche current, repetitive ³⁾	I_{AR}	8	A
Power Dissipation TO-220MF ($T_C = 25^\circ C$) - Derate above $25^\circ C$	P_D	31	W
		0.25	W/ $^\circ C$
Power Dissipation TO-220/TO-252/TO-263/TO-247 ($T_C = 25^\circ C$) - Derate above $25^\circ C$	P_D	83	W
		0.66	W/ $^\circ C$
Operating and Storage Temperature Range	T_J, T_{STG}	-55 to +150	$^\circ C$
Continuous diode forward current	I_S	8	A
Diode pulse current	$I_{S,pulse}$	24	A

Thermal Characteristics TO-220/TO-252/TO-263/TO-247

Parameter	Symbol	Value	Unit
Thermal Resistance, Junction-to-Case	$R_{\theta JC}$	1.5	$^{\circ}\text{C}/\text{W}$
Thermal Resistance, Junction-to-Ambient	$R_{\theta JA}$	62	$^{\circ}\text{C}/\text{W}$
Soldering temperature, wavesoldering only allowed at leads. (1.6mm from case for 10s)	T_{sold}	260	$^{\circ}\text{C}$

Thermal Characteristics TO-220MF

Parameter	Symbol	Value	Unit
Thermal Resistance, Junction-to-Case	$R_{\theta JC}$	4	$^{\circ}\text{C}/\text{W}$
Thermal Resistance, Junction-to-Ambient	$R_{\theta JA}$	62.5	$^{\circ}\text{C}/\text{W}$
Soldering temperature, wavesoldering only allowed at leads. (1.6mm from case for 10s)	T_{sold}	260	$^{\circ}\text{C}$

Package Marking and Ordering Information

Device	Device Package	Marking	Units/Tube	Units/Reel
LSC80R680GT	TO-220	LSC80R680GT	50	
LSD80R680GT	TO-220MF	LSD80R680GT	50	
LSE80R680GT	TO-263	LSE80R680GT		800
LSF80R680GT	TO-262	LSF80R680GT	50	
LSG80R680GT	TO-252	LSG80R680GT		2500
LSH80R680GT	TO-251	LSH80R680GT	72	
LSB80R680GT	TO-247	LSB80R680GT	30	

Electrical Characteristics $T_c = 25^{\circ}\text{C}$ unless otherwise noted

Parameter	Symbol	Test Condition	Min.	Typ.	Max.	Unit
Static characteristics						
Drain-source breakdown voltage	BV_{DSS}	$V_{GS}=0\text{ V}, I_D=0.25\text{ mA}$	800	-	-	V
Gate threshold voltage	$V_{GS(th)}$	$V_{DS}=V_{GS}, I_D=0.25\text{ mA}$	2.5	3.5	4.5	V
Drain cut-off current	I_{DSS}	$V_{DS}=800\text{ V}, V_{GS}=0\text{ V},$ $T_j = 25^{\circ}\text{C}$ $T_j = 125^{\circ}\text{C}$	-	-	1	μA
Gate leakage current, Forward	I_{GSSF}	$V_{GS}=30\text{ V}, V_{DS}=0\text{ V}$	-	-	100	nA
Gate leakage current, Reverse	I_{GSSR}	$V_{GS}=-30\text{ V}, V_{DS}=0\text{ V}$	-	-	-100	nA
Drain-source on-state resistance	$R_{DS(on)}$	$V_{GS}=10\text{ V}, I_D=4\text{ A}$ $T_j = 25^{\circ}\text{C}$ $T_j = 150^{\circ}\text{C}$	-	0.58	0.68	Ω
Gate resistance	R_G	$f=1\text{ MHz}, \text{open drain}$	-	7.6	-	Ω
Dynamic characteristics						
Input capacitance	C_{iss}	$V_{DS} = 100\text{ V}, V_{GS} = 0\text{ V},$	-	873	-	pF
Output capacitance	C_{oss}	$f = 250\text{ kHz}$	-	26	-	

Reverse transfer capacitance	C_{rss}		-	2.54	-	
Turn-on delay time	$t_{d(on)}$	$V_{DD} = 400V, I_D = 4A$ $R_G = 10\Omega, V_{GS}=10V$	-	12	-	ns
Rise time	t_r		-	30	-	
Turn-off delay time	$t_{d(off)}$		-	60	-	
Fall time	t_f		-	15	-	
Gate charge characteristics						
Gate to source charge	Q_{gs}	$V_{DD}=640V, I_D=4A,$ $V_{GS}=0 \text{ to } 10V$	-	4.5	-	nC
Gate to drain charge	Q_{gd}		-	7.2	-	
Gate charge total	Q_g		-	19.5	-	
	$V_{plateau}$		-	5	-	V
Reverse diode characteristics						
Diode forward voltage	V_{SD}	$V_{GS}=0V, I_F=4A$	-	-	1.4	V
Reverse recovery time	t_{rr}	$V_R=400V, I_F=4A,$ $dI_F/dt=100A/\mu s$	-	245	-	ns
Reverse recovery charge	Q_{rr}		-	2.33	-	μC
Peak reverse recovery current	I_{rrm}		-	19	-	A

Notes:

1. Limited by maximum junction temperature, maximum duty cycle is 0.75.
2. $I_{AS} = 2.8A, V_{DD} = 60V, \text{Starting } T_j = 25^\circ C.$
3. Repetitive Rating: Pulse width limited by maximum junction temperature.

Electrical Characteristics Diagrams

Figure 1. On-Region Characteristics

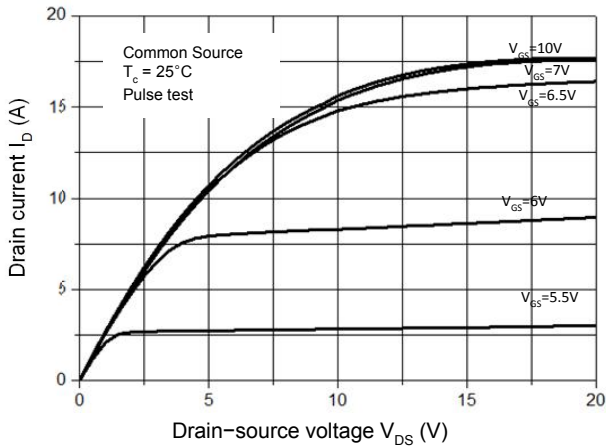

Figure 2. Transfer Characteristics

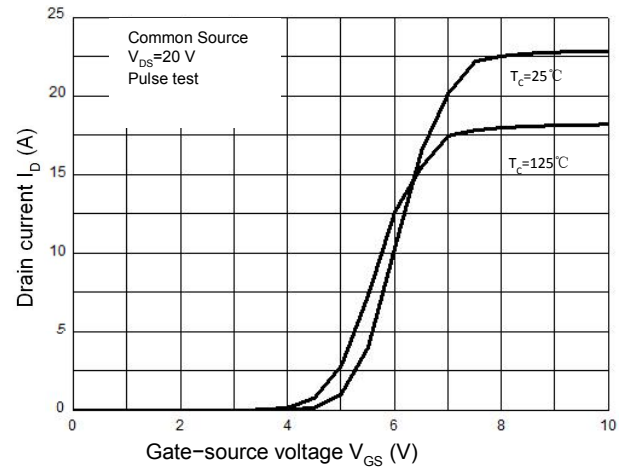

Figure 3. On-Resistance Variation vs. Drain Current

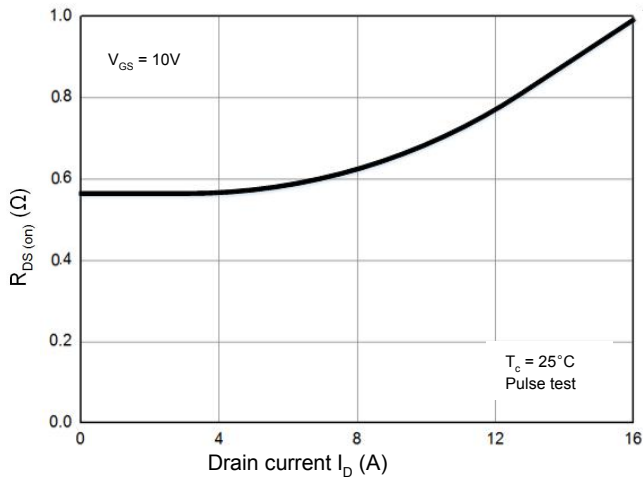

Figure 4. Threshold Voltage vs. Temperature

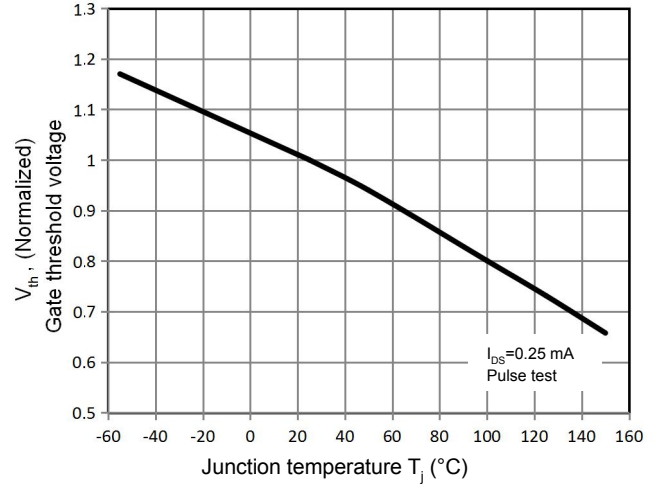

Figure 5. Breakdown Voltage vs. Temperature

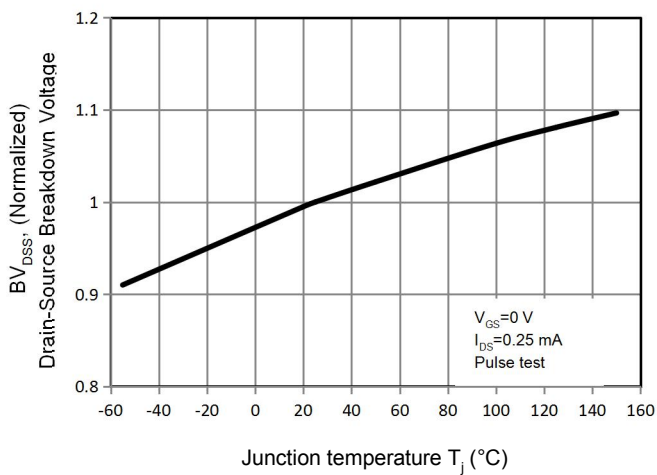

Figure 6. On-Resistance vs. Temperature

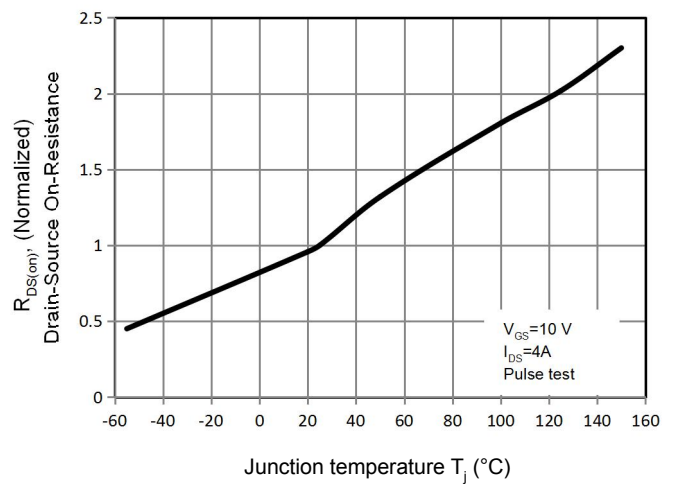

Figure 7. Capacitance Characteristics

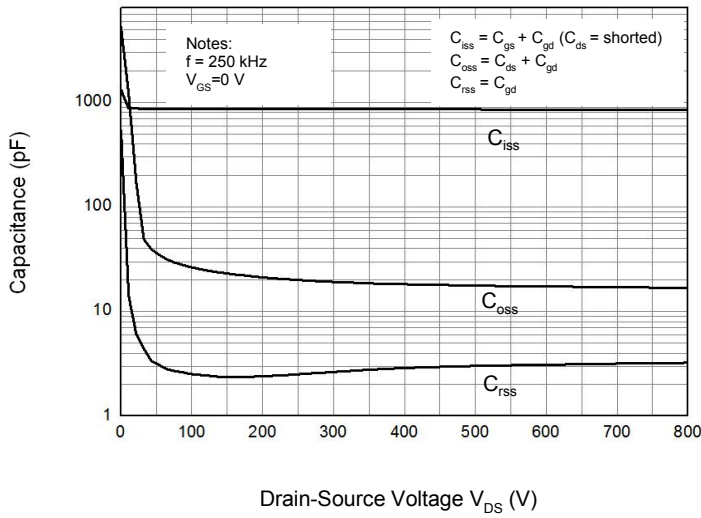

Figure 8. Gate Charge Characterist

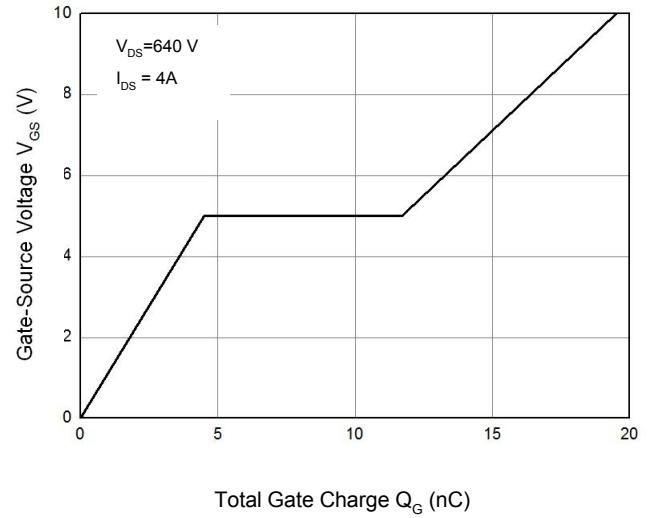

Figure 9.1 Maximum Safe Operating Area

TO-220MF

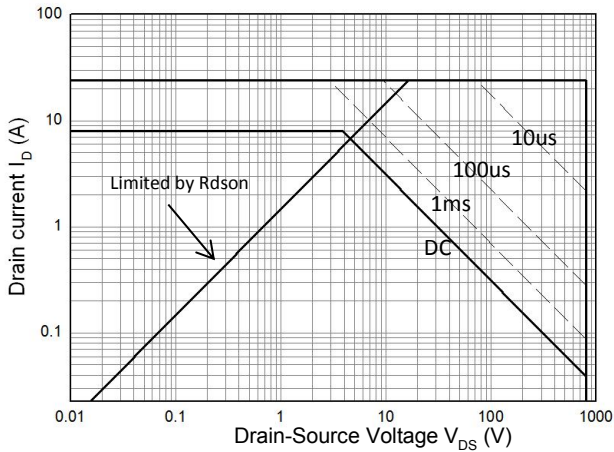

Figure 9.2 Maximum Safe Operating Area

TO-220/TO-252/TO-263/TO-247

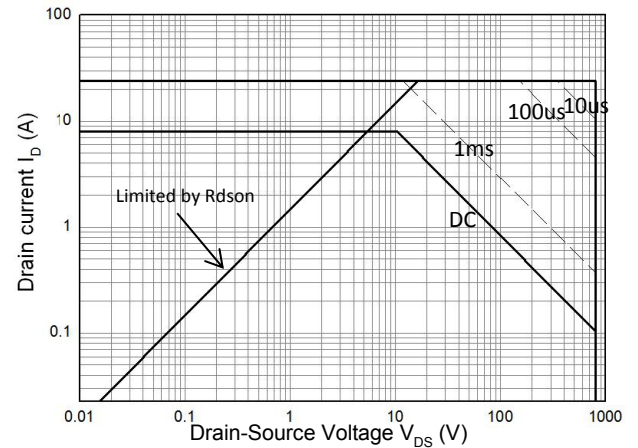

Figure 10.1 Power Dissipation vs. Temperature

TO-220MF

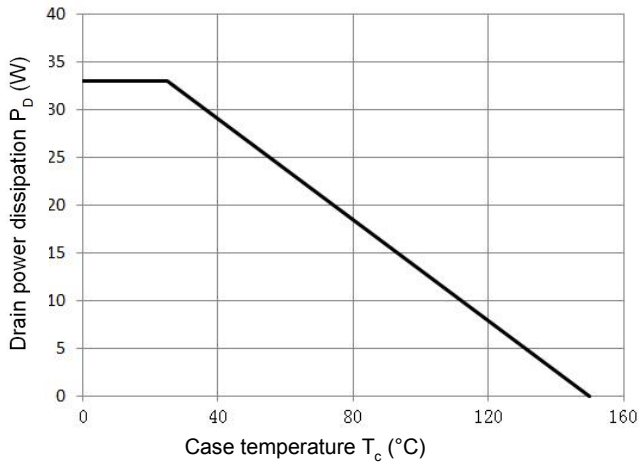
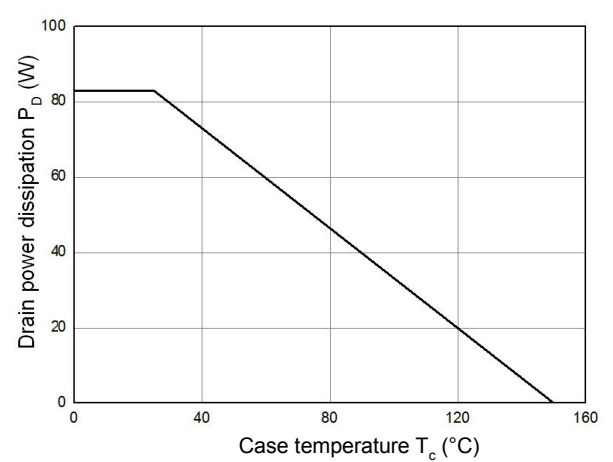
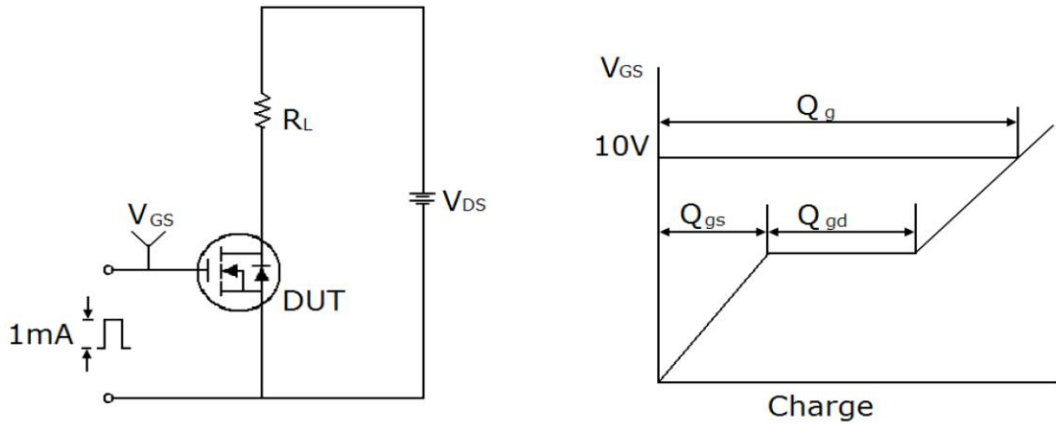

Figure 10.2 Power Dissipation vs. Temperature

TO-220/TO-252/TO-263/TO-247



Gate Charge Test Circuit & Waveform



Switching Test Circuit & Waveforms

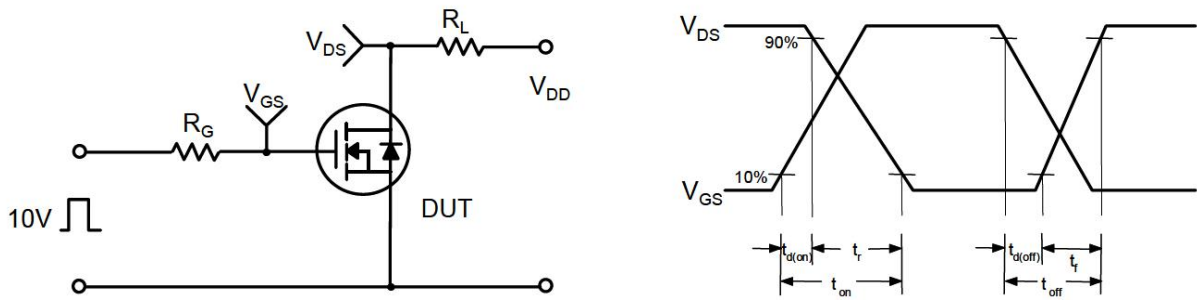

Unclamped Inductive Switching Test Circuit & Waveforms

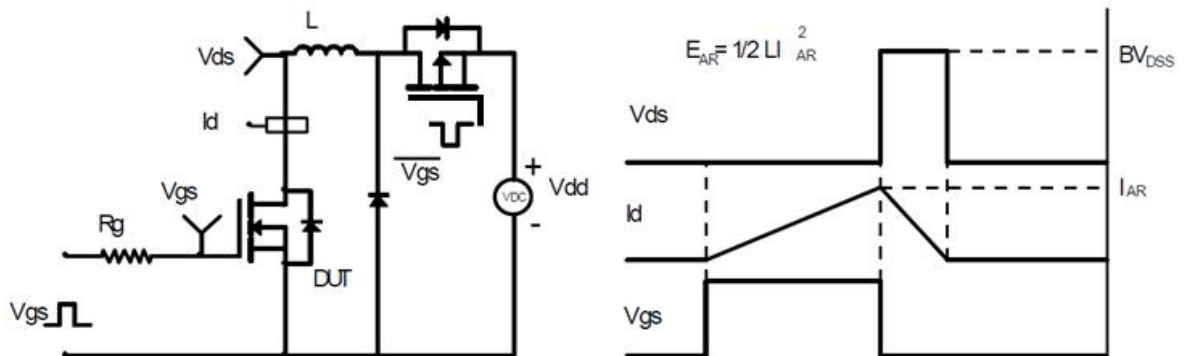

Mechanical Dimensions for TO-220

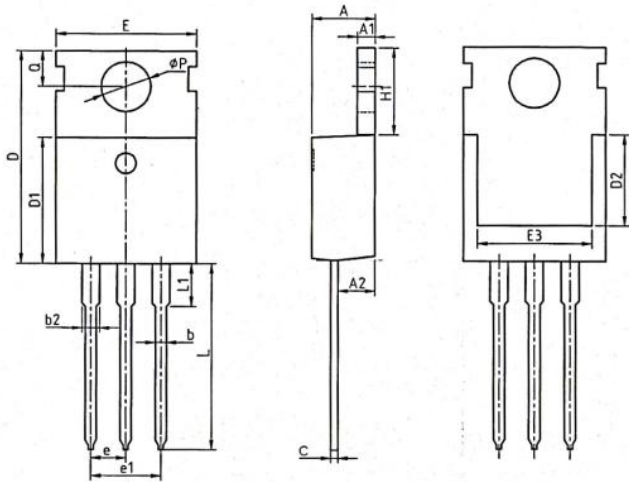

COMMON DIMENSIONS						
SYMBOL	MM			INCH		
	MIN	NOM	MAX	MIN	NOM	MAX
A	4.37	4.57	4.70	0.172	0.180	0.185
A1	1.25	1.30	1.40	0.049	0.051	0.055
A2	2.20	2.40	2.60	0.087	0.094	0.102
b	0.70	0.80	0.95	0.028	0.031	0.037
b2	1.17	1.27	1.47	0.046	0.050	0.058
c	0.45	0.50	0.60	0.018	0.020	0.024
D	15.10	15.60	16.10	0.594	0.614	0.634
D1	8.80	9.10	9.40	0.346	0.358	0.370
D2	5.50	—	—	0.217	—	—
E	9.70	10.00	10.30	0.382	0.394	0.406
E3	7.00	—	—	0.276	—	—
e	2.54BSC			0.1BSC		
e1	5.08BSC			0.2BSC		
H1	6.25	6.50	6.85	0.246	0.256	0.270
L	12.75	13.50	13.80	0.502	0.531	0.543
L1	—	3.10	3.40	—	0.122	0.134
Øp	3.40	3.60	3.80	0.134	0.142	0.150
Q	2.60	2.80	3.00	0.102	0.110	0.118

TO-220 Part Marking Information

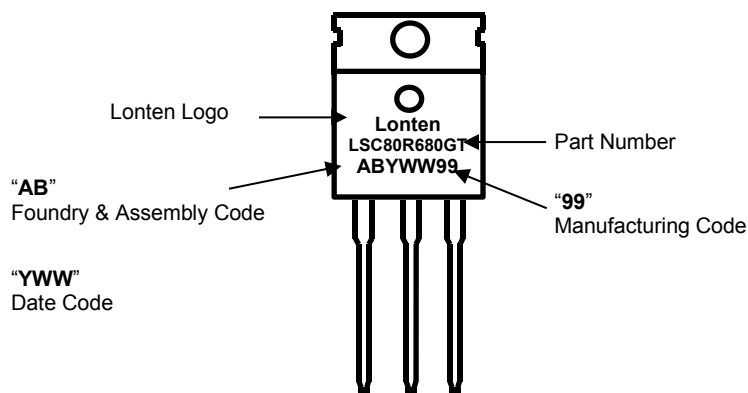

Mechanical Dimensions for TO-220MF

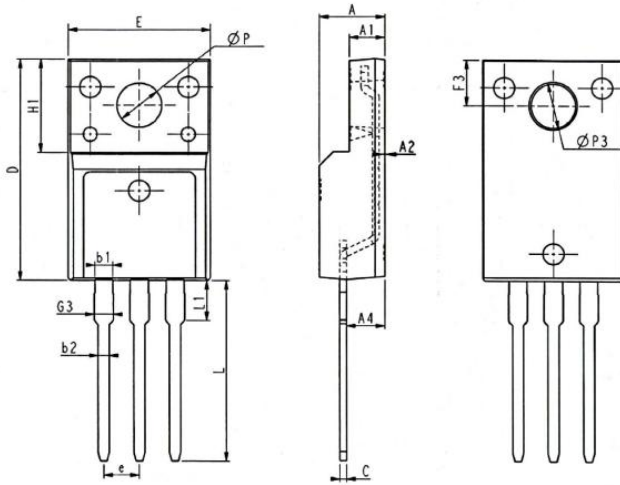

COMMON DIMENSIONS						
SYMBOL	MM			INCH		
	MIN	NOM	MAX	MIN	NO	MA
E	9.96	10.1	10.3	0.39	0.40	0.40
A	4.50	4.70	4.90	0.17	0.18	0.19
A1	2.34	2.54	2.74	0.09	0.10	0.10
A2	0.30	0.45	0.60	0.01	0.00	0.02
A4	2.65	2.76	2.96	0.10	0.10	0.11
C	0.40	0.50	0.65	0.01	0.02	0.02
D	15.57	15.8	16.1	0.61	0.62	0.63
H1	6.70REF			0.264REF		
e	2.54BSC			0.1BSC		
ØP	3.03	3.18	3.38	0.11	0.12	0.13
L	12.68	12.9	13.2	0.49	0.51	0.52
L1	2.88	3.03	3.18	0.11	0.11	0.12
ØP3	3.15REF			0.124REF		
F3	3.15	3.30	3.45	0.12	0.13	0.13
G3	1.25	1.35	1.55	0.04	0.05	0.06
b1	1.18	1.28	1.43	0.04	0.05	0.05
b2	0.70	0.80	0.95	0.02	0.03	0.03

TO-220MF Part Marking Information

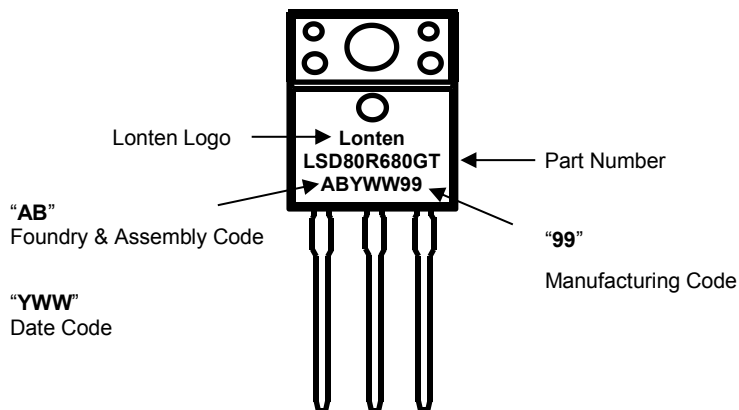

Mechanical Dimensions for TO-251

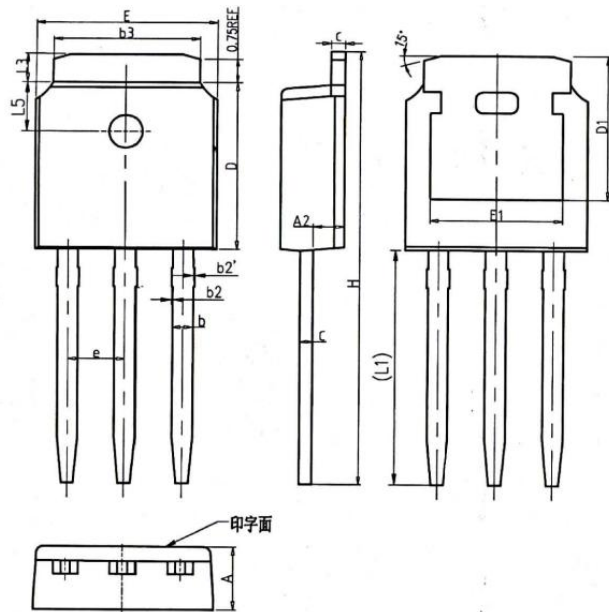

COMMON DIMENSIONS			
SYMBOL	MM		
	MIN	NOM	MAX
A	2.20	2.30	2.38
A2	0.97	1.07	1.17
b	0.68	0.78	0.90
b2	0.00	0.04	0.10
b2'	0.00	0.04	0.10
b3	5.20	5.33	5.46
c	0.43	0.53	0.61
D	5.98	6.10	6.22
D1	5.30REF		
E	6.40	6.60	6.73
E1	4.63	—	—
e	2.286BSC		
H	16.22	16.52	16.82
L1	9.15	9.40	9.65
L3	0.88	1.02	1.28
L5	1.65	1.80	1.95

TO-251 Part Marking Information

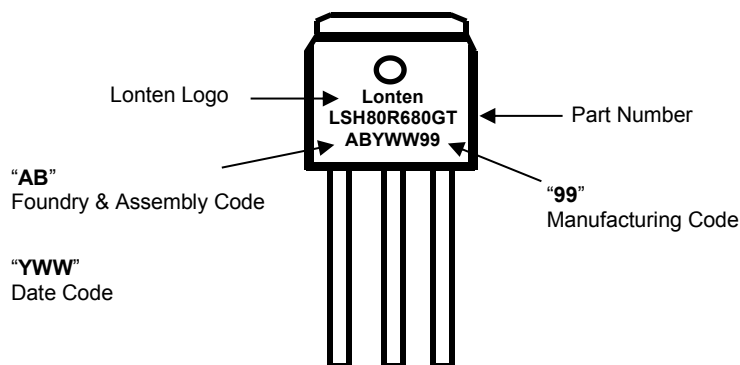

Mechanical Dimensions for TO-252

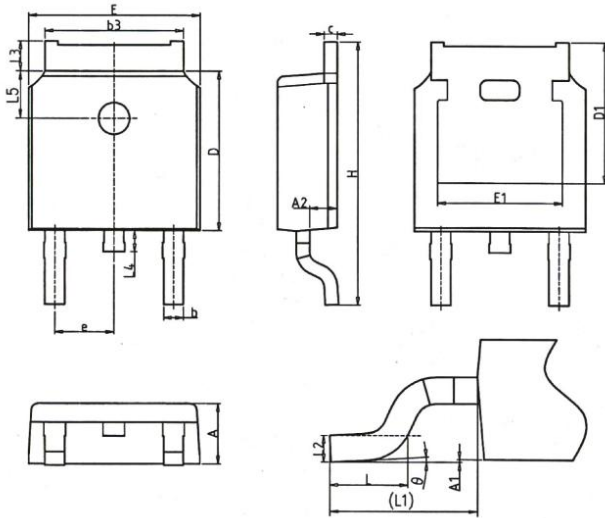

COMMON DIMENSIONS			
SYMBOL	mm		
	MIN	NOM	MAX
A	2.20	2.30	2.38
A1	0.00	—	0.20
A2	0.97	1.07	1.17
b	0.68	0.78	0.90
b3	5.20	5.33	5.46
c	0.43	0.53	0.61
D	5.98	6.10	6.22
D1	5.30REF		
E	6.40	6.60	6.73
E1	4.63	—	—
e	2.286BSC		
H	9.40	10.10	10.50
L	1.38	1.50	1.75
L1	2.90REF		
L2	0.51BSC		
L3	0.88	—	1.28
L4	0.50	—	1.00
L5	1.65	1.80	1.95
θ	0°	—	8°

TO-252 Part Marking Information

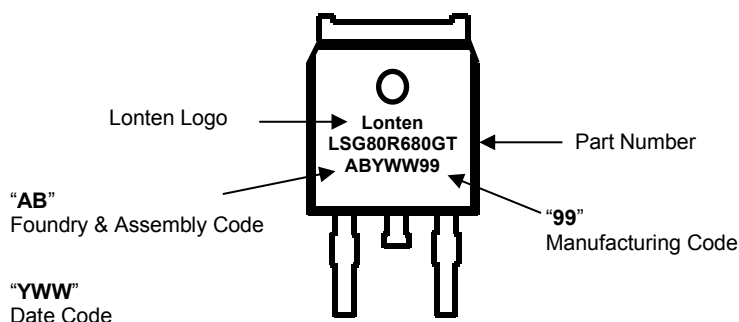

Mechanical Dimensions for TO-263

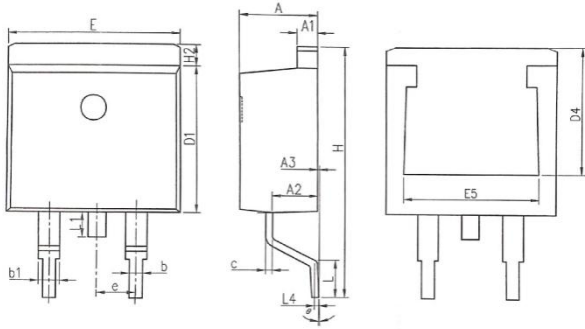

COMMON DIMENSIONS						
SYMBOL	MM			INCH		
	MIN	NOM	MAX	MIN	NOM	MAX
A	4.37	4.57	4.77	0.172	0.180	0.188
A1	1.22	1.27	1.42	0.048	0.050	0.056
A2	2.49	2.89	2.89	0.098	0.114	0.114
A3	0.00	0.13	0.25	0.000	0.005	0.010
b	0.70	0.81	0.96	0.028	0.032	0.034
b1	1.17	1.27	1.47	0.046	0.050	0.058
c	0.30	0.38	0.53	0.012	0.015	0.021
D1	8.50	8.70	8.90	0.335	0.343	0.350
D4	6.60	—	—	0.260	—	—
E	9.86	10.16	10.36	0.389	0.400	0.408
E5	7.06	—	—	0.278	—	—
e	2.54 BSC			0.100 BSC		
H	14.70	15.10	15.50	0.579	0.594	0.610
H2	1.07	1.27	1.47	0.042	0.050	0.058
L	2.00	2.30	2.60	0.079	0.091	0.102
L1	1.40	1.55	1.70	0.055	0.061	0.067
L4	0.25 BSC			0.010 BSC		
θ	0°	5°	9°	0°	0.197°	0.354°

TO-263 Part Marking Information

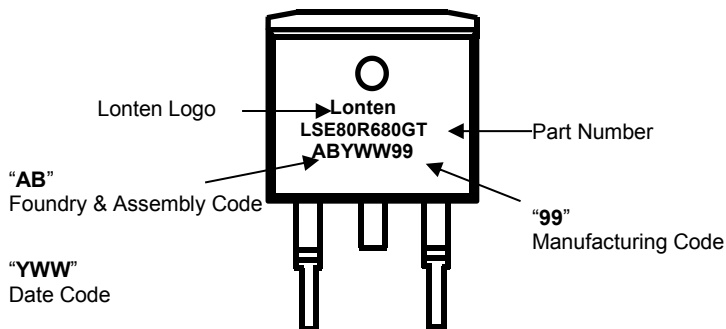

Mechanical Dimensions for TO-262

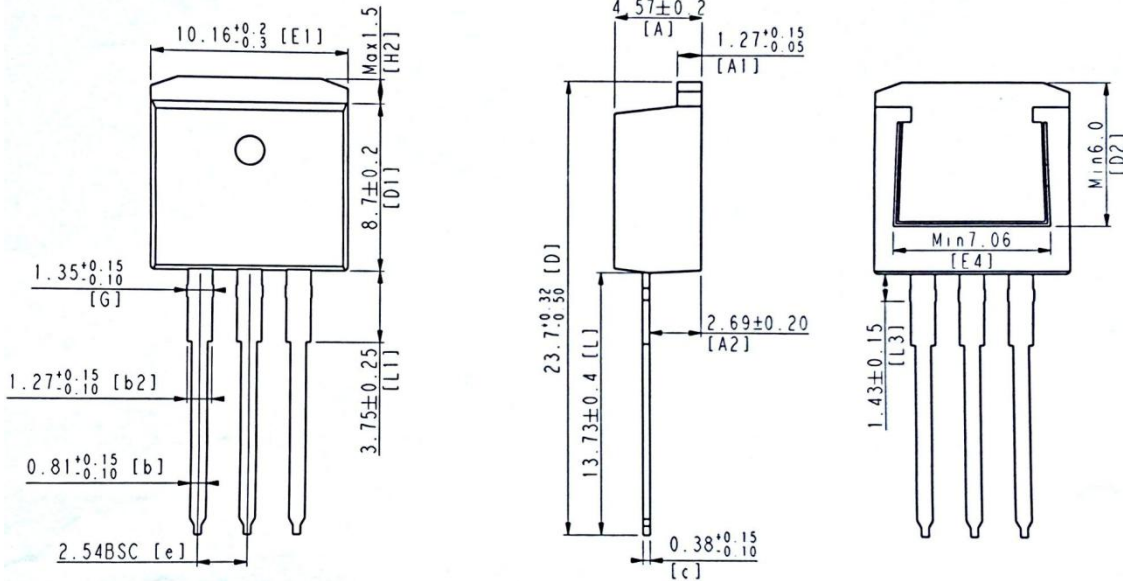

TO-262 Part Marking Information

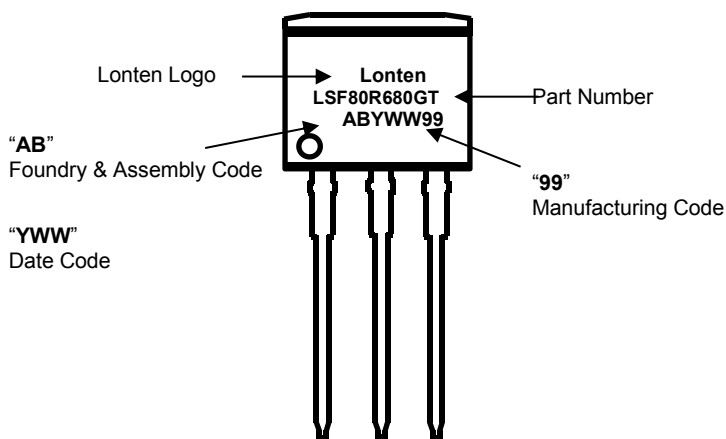

Mechanical Dimensions for TO-247

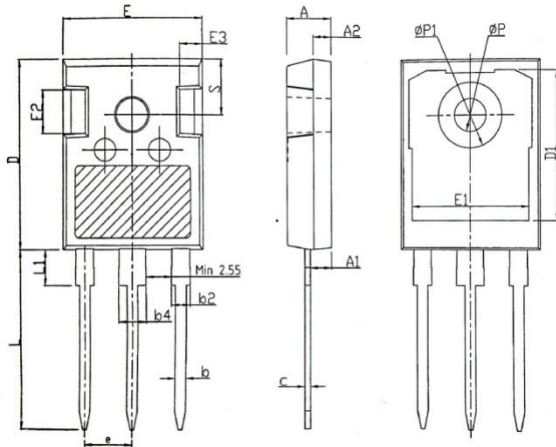

SYMBOL	mm		
	MIN	NOM	MAX
A	4.80	5.00	5.20
A1	2.21	2.41	2.59
A2	1.85	2.00	2.15
b	1.11	1.21	1.36
b2	1.91	2.01	2.21
b4	2.91	3.01	3.21
c	0.51	0.61	0.75
D	20.80	21.00	21.30
D1	16.25	16.55	16.85
E	15.50	15.80	16.10
E1	13.00	13.30	13.60
E2	4.80	5.00	5.20
E3	2.30	2.50	2.70
e	5.44BSC		
L	19.82	19.92	20.22
L1	—	—	4.30
ØP	3.40	3.60	3.80
ØP1	—	—	7.30
S	6.15BSC		

TO-247 Part Marking Information

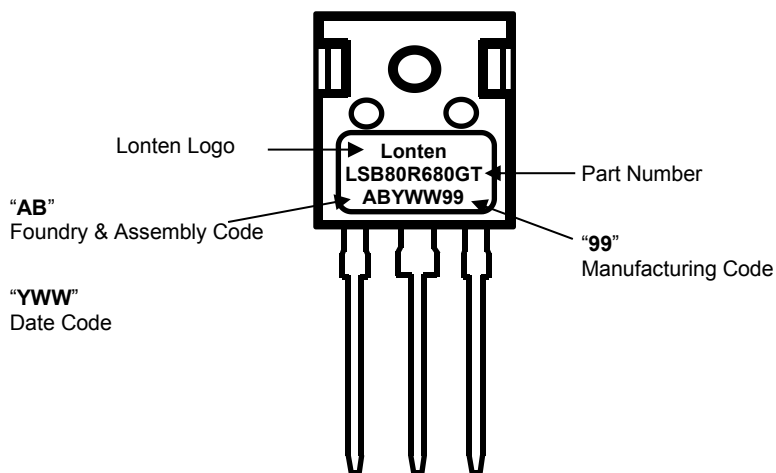

Disclaimer

The content specified herein is for the purpose of introducing LONTEN's products (hereinafter "Products"). The information given in this document shall in no event be regarded as a guarantee of conditions or characteristics. Examples of application circuits, circuit constants and any other information contained herein illustrate the standard usage and operations of the Products. The peripheral conditions must be taken into account when designing circuits for mass production.

LONTEN does not assume any liability for infringement of patents, copyrights, or other intellectual property rights of third parties by or arising from the use of the Products or technical information described in this document.

The Products are not designed or manufactured to be used with any equipment, device or system which requires an extremely high level of reliability the failure or malfunction of which may result in a direct threat to human life or create a risk of human injury (such as a medical instrument, transportation equipment, aerospace machinery, nuclear-reactor controller, fuel-controller or other safety device). LONTEN shall bear no responsibility in any way for use of any of the Products for the above special purposes.

Although LONTEN endeavors to improve the quality and reliability of its products, semiconductor products have specific characteristics such as the occurrence of failure at a certain rate and malfunctions under certain use conditions. Please be sure to implement safety measures to guard them against the possibility of physical injury, and injury or damage caused by fire in the event of the failure of a LONTEN product.

The content specified herein is subject to change for improvement without notice. When using a LONTEN product, be sure to obtain the latest specifications.

X-ON Electronics

Largest Supplier of Electrical and Electronic Components

Click to view similar products for [MOSFET](#) category:

Click to view products by [Lonten Semiconductor](#) manufacturer:

Other Similar products are found below :

[IRFD120](#) [JANTX2N5237](#) [BUK455-60A/B](#) [MIC4420CM-TR](#) [VN1206L](#) [NDP4060](#) [SI4482DY](#) [IPS70R2K0CEAKMA1](#) [SQD23N06-31L-GE3](#)
[TK16J60W,S1VQ\(O](#) [2SK2614\(TE16L1,Q\)](#) [DMN1017UCP3-7](#) [DMN1053UCP4-7](#) [SQJ469EP-T1-GE3](#) [NTE2384](#) [DMC2700UDMQ-7](#)
[DMN2080UCB4-7](#) [DMN61D9UWQ-13](#) [US6M2GTR](#) [DMN31D5UDJ-7](#) [DMP22D4UFO-7B](#) [DMN1006UCA6-7](#) [DMN16M9UCA6-7](#)
[STF5N65M6](#) [IRF40H233XTMA1](#) [STU5N65M6](#) [DMN6022SSD-13](#) [DMN13M9UCA6-7](#) [DMTH10H4M6SPS-13](#) [DMN2990UFB-7B](#)
[IPB80P04P405ATMA2](#) [2N7002W-G](#) [MCAC30N06Y-TP](#) [MCQ7328-TP](#) [BXP7N65D](#) [BXP4N65F](#) [AOL1454G](#) [WMJ80N60C4](#) [BXP2N20L](#)
[BXP2N65D](#) [BXT1150N10J](#) [BXT1700P06M](#) [TSM60NB380CP ROG](#) [RQ7L055BGTCTCR](#) [DMNH15H110SK3-13](#) [SLF10N65ABV2](#)
[BSO203SP](#) [BSO211P](#) [IPA60R230P6](#) [IPA60R460CE](#)