

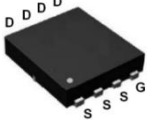
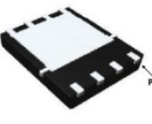

## Lonten N-channel 30V, 120A, 2.0mΩ Power MOSFET

<p><b>Description</b>                  These N-Channel enhancement mode power field effect transistors are using split gate trench DMOS technology. This advanced technology has been especially tailored to minimize on-state resistance, provide superior switching performance, and with stand high energy pulse in the avalanche and commutation mode. These devices are well suited for high efficiency fast switching applications.</p> <p><b>Features</b></p> <ul style="list-style-type: none"> <li>◆ 30V,120A, <math>R_{DS(on),max} = 2.0m\Omega @ V_{GS} = 10V</math></li> <li>◆ Improved dv/dt capability</li> <li>◆ Fast switching</li> <li>◆ 100% EAS Guaranteed</li> <li>◆ Green device available</li> </ul> <p><b>Applications</b></p> <ul style="list-style-type: none"> <li>◆ Motor Drives</li> <li>◆ UPS</li> <li>◆ DC-DC Converter</li> </ul>	<p><b>Product Summary</b></p> <table style="width: 100%; border: none;"> <tr> <td style="padding: 2px;"><math>V_{DSS}</math></td> <td style="padding: 2px;">30V</td> </tr> <tr> <td style="padding: 2px;"><math>R_{DS(on),max} @ V_{GS}=10V</math></td> <td style="padding: 2px;">2.0mΩ</td> </tr> <tr> <td style="padding: 2px;"><math>I_D</math></td> <td style="padding: 2px;">120A</td> </tr> </table> <p><b>Pin Configuration</b></p> <div style="display: flex; justify-content: space-around; align-items: center;"> <div style="text-align: center;">  <p><b>PPAK5x6</b></p> </div> <div style="text-align: center;">  <p><b>TO-252</b></p> </div> <div style="text-align: center;">  <p><b>TO-220</b></p> </div> </div> <div style="text-align: right; margin-top: 20px;">  <p style="margin-top: 10px;">N-Channel MOSFET <span style="float: right; border: 1px solid black; border-radius: 50%; padding: 2px;">Pb</span></p> </div>	$V_{DSS}$	30V	$R_{DS(on),max} @ V_{GS}=10V$	2.0mΩ	$I_D$	120A
$V_{DSS}$	30V						
$R_{DS(on),max} @ V_{GS}=10V$	2.0mΩ						
$I_D$	120A						

### Absolute Maximum Ratings $T_C = 25^\circ C$ unless otherwise noted

Parameter	Symbol	Value	Unit
Drain-Source Voltage	$V_{DSS}$	30	V
Continuous drain current ( $T_C = 25^\circ C$ ) <sup>1)</sup>	$I_D$	120	A
Continuous drain current ( $T_C = 100^\circ C$ ) <sup>1)</sup>		101	A
Pulsed drain current <sup>2)</sup>	$I_{DM}$	360	A
Gate-Source voltage	$V_{GSS}$	$\pm 18$	V
Avalanche energy <sup>3)</sup>	$E_{AS}$	225	mJ
Power Dissipation ( $T_C = 25^\circ C$ )	$P_D$	42.14	W
Storage Temperature Range	$T_{STG}$	-55 to +150	$^\circ C$
Operating Junction Temperature Range	$T_J$	-55 to +150	$^\circ C$

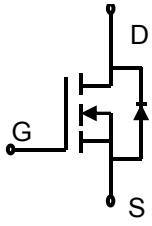
### Thermal Characteristics

Parameter	Symbol	Value	Unit
Thermal Resistance, Junction-to-Case	$R_{\theta JC}$	1.67	$^\circ C/W$

**Package Marking and Ordering Information**

Device	Device Package	Marking
LSGN03R020	DFN5X6	LSGN03R020
LSGG03R020	TO-252	LSGG03R020
LSGC03R020	TO-220	LSGC03R020

**Electrical Characteristics**
 $T_J = 25^\circ\text{C}$  unless otherwise noted

Parameter	Symbol	Test Condition	Min.	Typ.	Max.	Unit
<b>Static characteristics</b>						
Drain-source breakdown voltage	$BV_{DSS}$	$V_{GS}=0\text{ V}, I_D=250\mu\text{A}$	30	---	---	V
Gate threshold voltage	$V_{GS(th)}$	$V_{DS}=V_{GS}, I_D=250\mu\text{A}$	1.1	1.5	2.2	V
Drain-source leakage current	$I_{DSS}$	$V_{DS}=30\text{ V}, V_{GS}=0\text{ V}, T_J = 25^\circ\text{C}$	---	---	1	$\mu\text{A}$
Gate leakage current, Forward	$I_{GSSF}$	$V_{GS}=18\text{ V}, V_{DS}=0\text{ V}$	---	---	100	nA
Gate leakage current, Reverse	$I_{GSSR}$	$V_{GS}=-18\text{ V}, V_{DS}=0\text{ V}$	---	---	-100	nA
Drain-source on-state resistance	$R_{DS(on)}$	$V_{GS}=10\text{ V}, I_D=30\text{ A}$	---	1.5	2.0	m $\Omega$
- DFN5×6/TO-220						
- TO-252			---	1.6	2.1	m $\Omega$
Forward transconductance	$g_{fs}$	$V_{DS} = 10\text{ V}, I_D=60\text{ A}$	---	60	---	S
<b>Dynamic characteristics</b>						
Input capacitance	$C_{iss}$	$V_{DS} = 15\text{ V}, V_{GS} = 0\text{ V},$ $F = 1\text{ MHz}$	---	3410	---	pF
Output capacitance	$C_{oss}$		---	1830	---	
Reverse transfer capacitance	$C_{rss}$		---	112	---	
Turn-on delay time	$t_{d(on)}$	$V_{DD} = 15\text{ V}, V_{GS}=10\text{ V}, I_D = 15\text{ A}$ $R_G=10\Omega$	---	22	---	ns
Rise time	$t_r$		---	15	---	
Turn-off delay time	$t_{d(off)}$		---	130	---	
Fall time	$t_f$		---	47	---	
<b>Gate charge characteristics</b>						
Gate to source charge	$Q_{gs}$	$V_{DS}=15\text{ V}, I_D=15\text{ A},$ $V_{GS}= 10\text{ V}$	---	8.5	---	nC
Gate to drain charge	$Q_{gd}$		---	9.5	---	
Gate charge total	$Q_g$		---	50	---	
<b>Drain-Source diode characteristics and Maximum Ratings</b>						
Continuous Source Current	$I_S$		---	---	120	A
Pulsed Source Current <sup>4)</sup>	$I_{SM}$		---	---	360	A
Diode Forward Voltage	$V_{SD}$	$V_{GS}=0\text{ V}, I_S=40\text{ A}, T_J=25^\circ\text{C}$	---	0.85	1.2	V
Reverse Recovery Time	$t_{rr}$	$I_S=I_F, di/dt=100\text{ A}/\mu\text{s}, T_J=25^\circ\text{C}$ <sup>5)</sup>	---	---	80	ns
Reverse Recovery Charge	$Q_{rr}$		---	---	80	nC

**Notes:**

- 1: The maximum junction current rating is package limited.
- 2: Repetitive Rating: Pulse width limited by maximum junction temperature.
- 3:  $V_{DD}=23\text{ V}, V_{GS}=10\text{ V}, L=0.5\text{ mH}, I_{AS}=30\text{ A}, R_G=25\Omega$ , Starting  $T_J=25^\circ\text{C}$ .
- 4: Pulse Test: Pulse Width  $\leq 300\ \mu\text{s}$ , Duty Cycle  $\leq 2\%$ .
- 5: Guaranteed by design, not subject to production.

**Electrical Characteristics Diagrams**

Figure 1. Typ. Output Characteristics

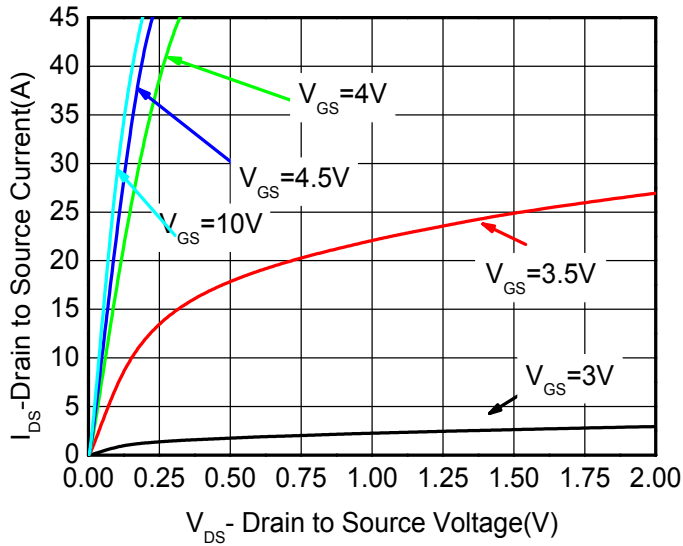

Figure 2. Transfer Characteristics

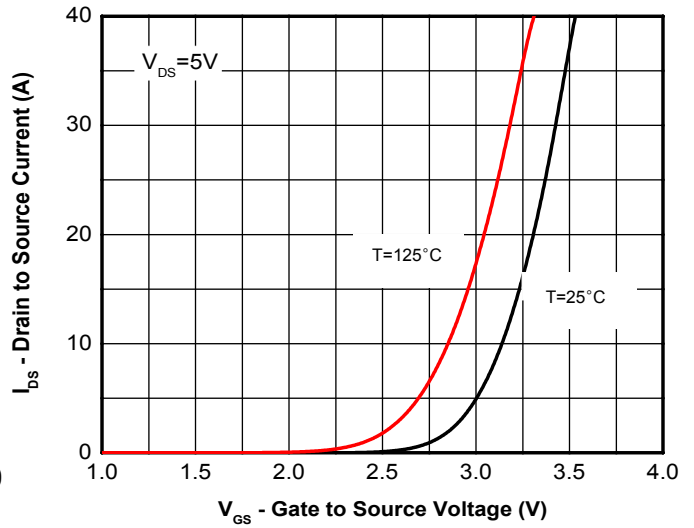

Figure 3. Capacitance Characteristics

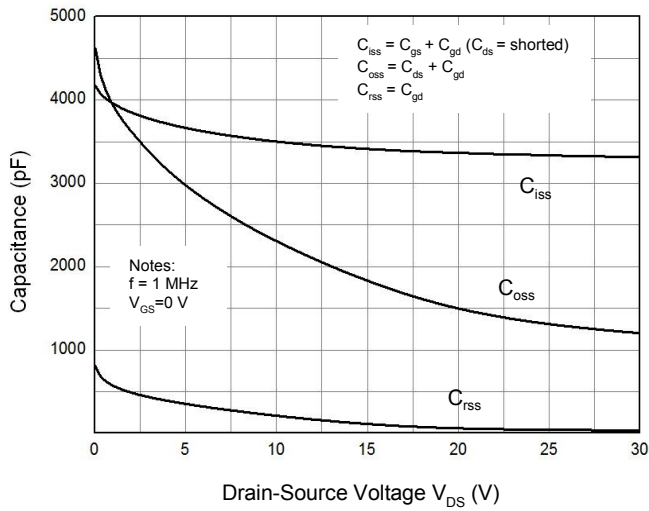

Figure 4. Gate Charge Waveform

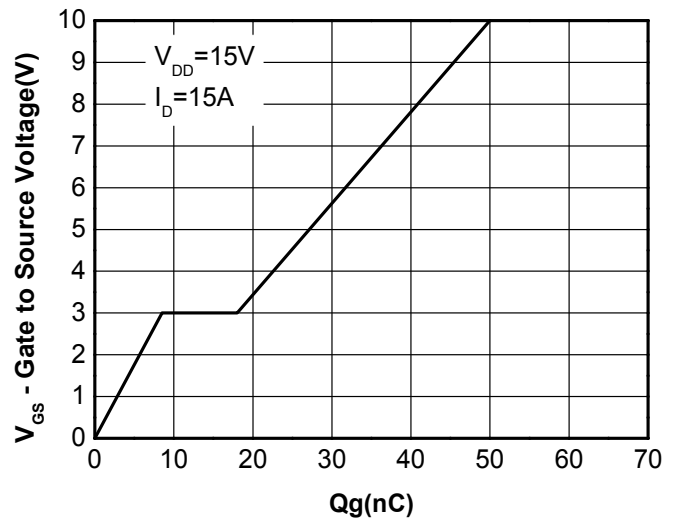

Figure 5. Body-Diode Characteristics

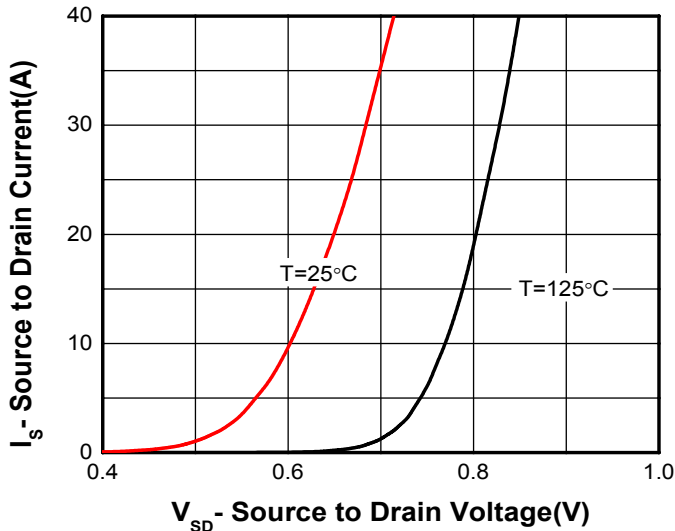

Figure 6. Rds(on)-Drain Current

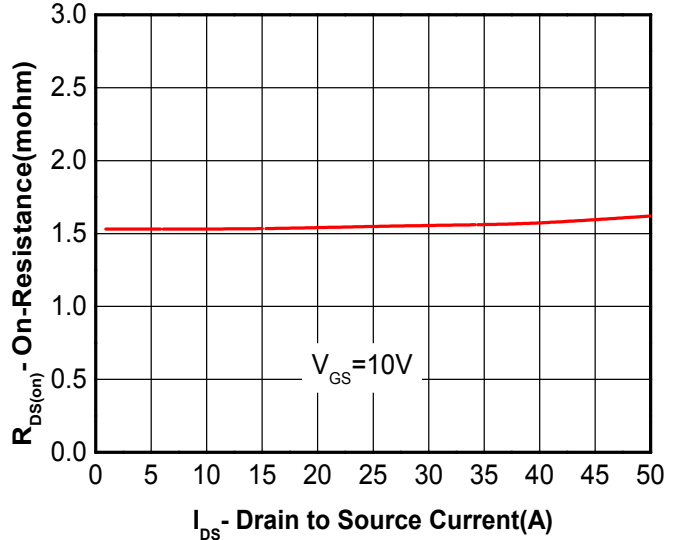

Figure 7. R<sub>ds(on)</sub>-Junction Temperature(°C)

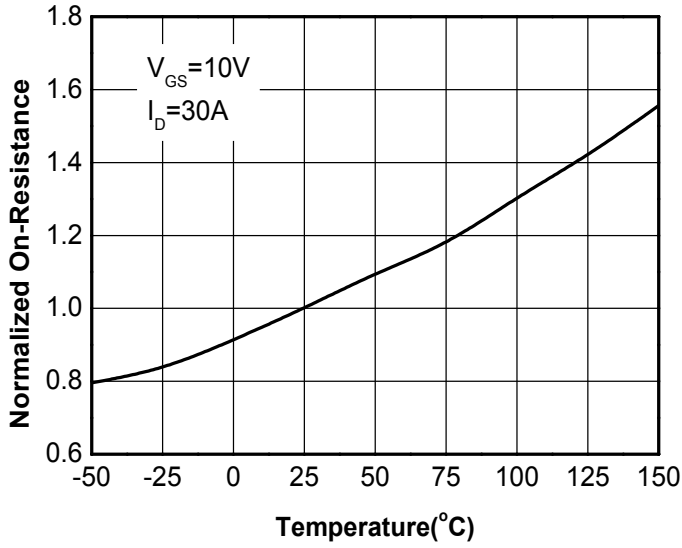

Figure 8. Maximum Safe Operating Area

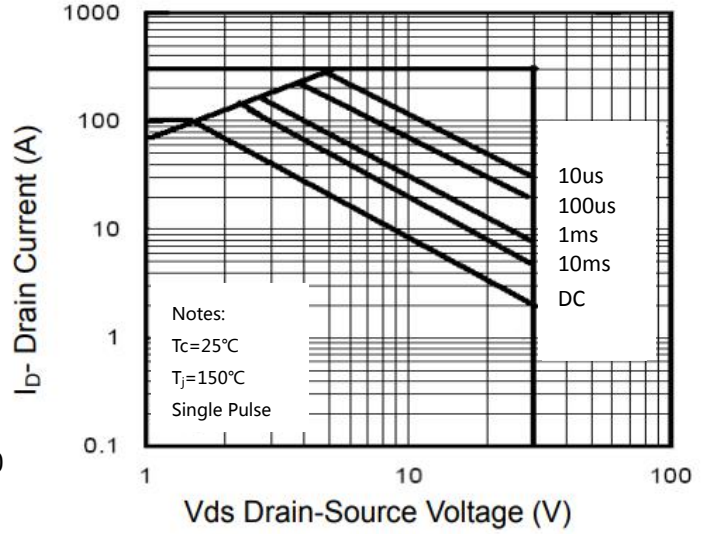

Figure 9. On-Resistance vs. Gate-to-Source voltage

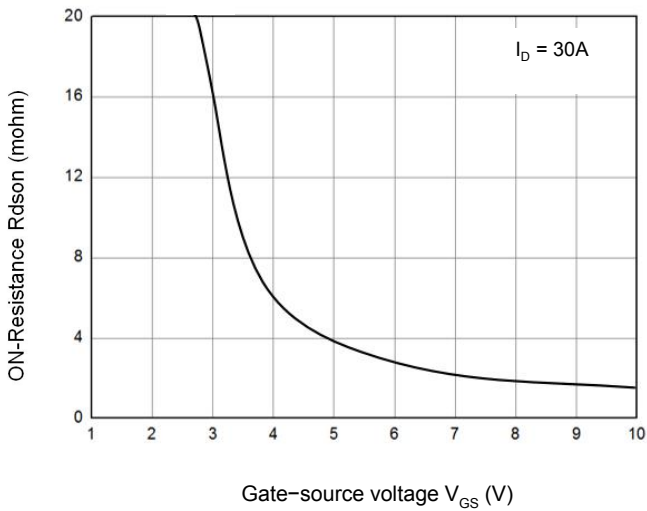

Figure 10. BV<sub>DSS</sub> vs. Junction temperature

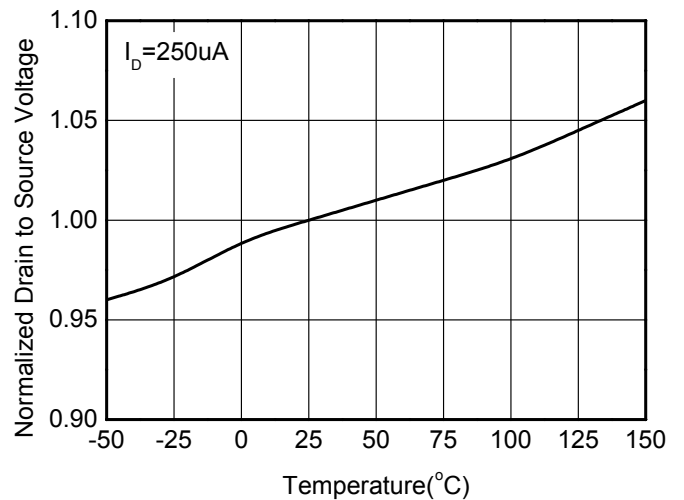
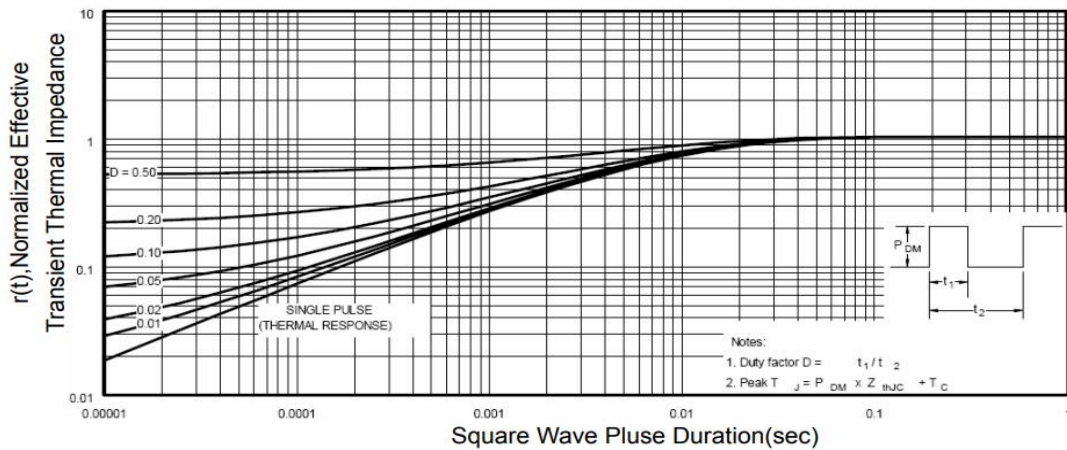

Figure 11. Normalized Maximum Transient Thermal Impedance (R<sub>thJC</sub>)



### Test Circuit & Waveform

Figure 12. Gate Charge Test Circuit & Waveform

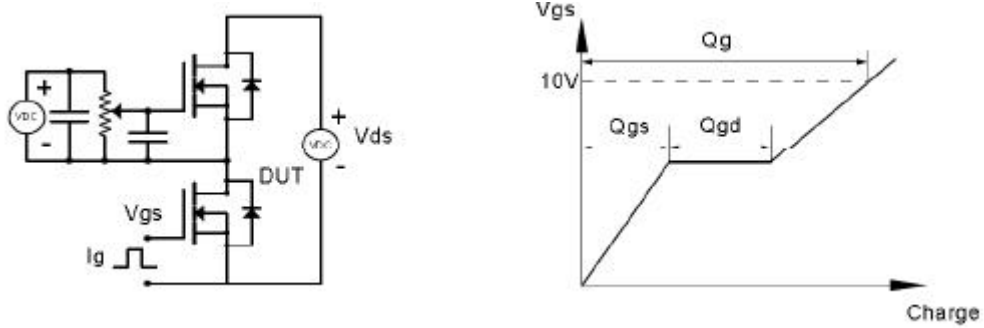

Figure 13. Resistive Switching Test Circuit & Waveforms

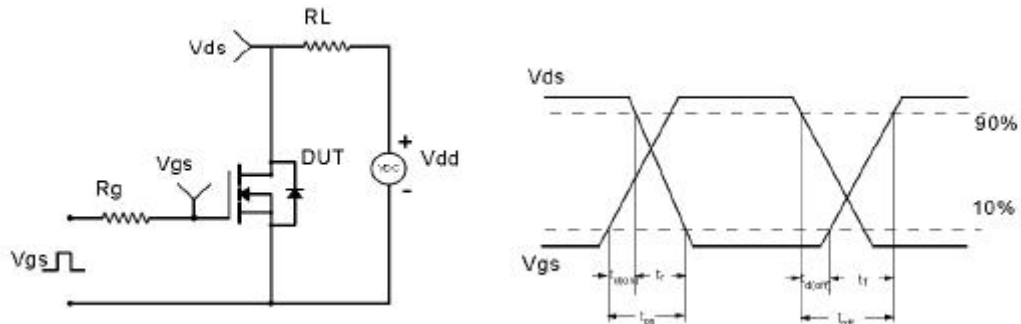

Figure 14. Unclamped Inductive Switching (UIS) Test Circuit & Waveform

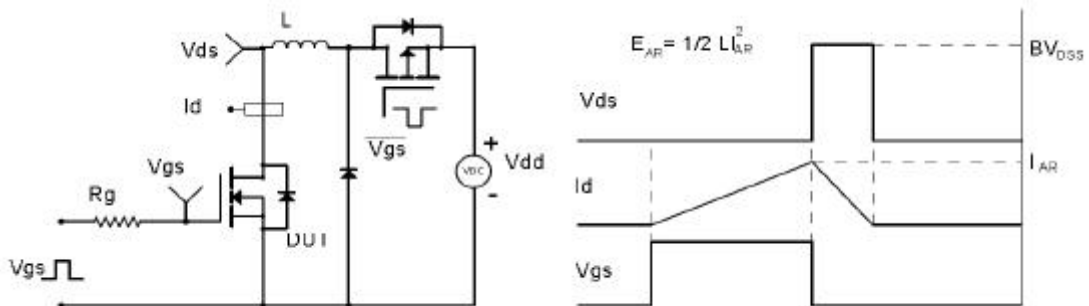
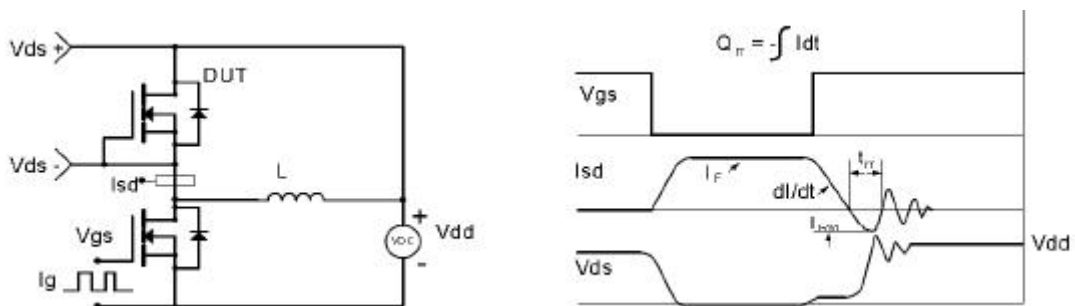
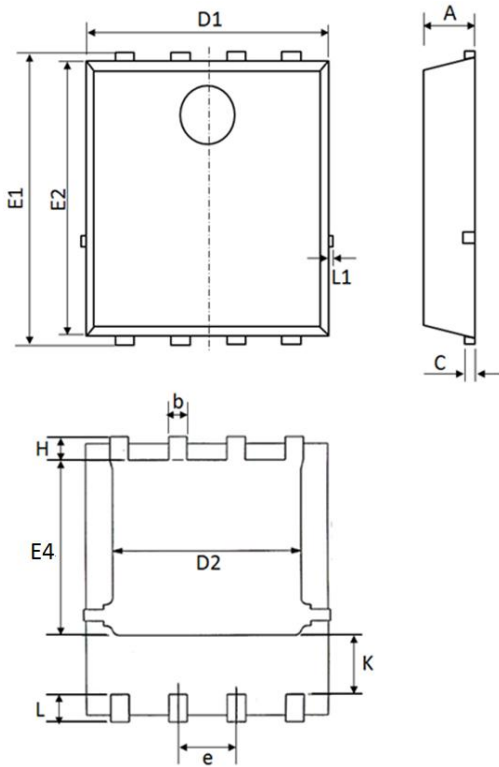

Figure 15. Diode Recovery Circuit & Waveform



**Mechanical Dimensions for PPAK5×6**



COMMON DIMENSIONS						
SYMBOL	MILLIMETERS			INCHS		
	MIN	NOM	MAX	MIN	NOM	MAX
A	1	1.1	1.2	0.039	0.043	0.047
b	0.3	0.4	0.5	0.012	0.016	0.020
C	0.154	0.254	0.354	0.006	0.010	0.014
D1	5	5.2	5.4	0.197	0.205	0.213
D2	3.8	4.1	4.25	0.150	0.161	0.167
E1	5.95	6.15	6.35	0.234	0.242	0.250
E2	5.66	5.86	6.06	0.223	0.231	0.239
E4	3.52	3.72	3.92	0.139	0.146	0.154
e	1.27 BSC			0.050 BSC		
H	0.4	0.5	0.6	0.016	0.020	0.024
L	0.5	0.6	0.7	0.020	0.024	0.028
L1	-	-	0.12	-	-	0.005
K	1.14	1.29	1.44	0.045	0.051	0.057

**PPAK5×6 Part Marking Information**

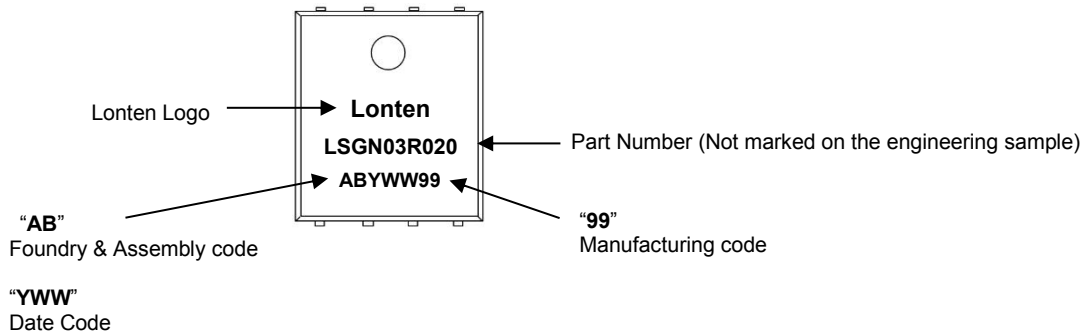

Calendar Year	Year Code	Calendar Week	Week Code
2018	G	Workweek 01	01
2019	H	Workweek 02	02
2020	I	Workweek 03	03
2021	J	Workweek 04	04
2022	K	Workweek 05	05
2023	L	Workweek 06	06
2024	M	.....	.....

**Mechanical Dimensions for TO-252**

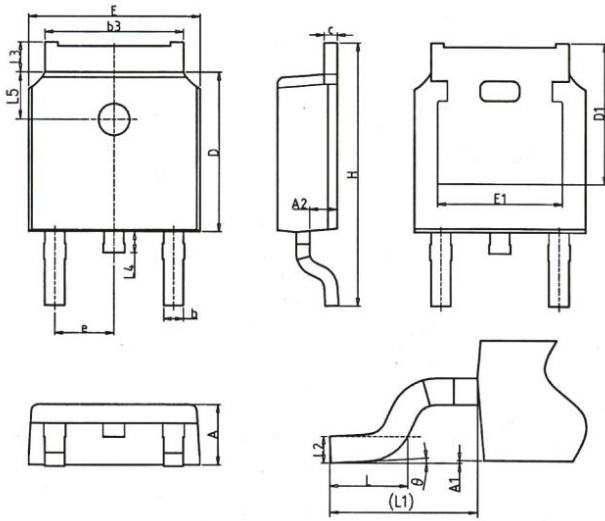

COMMON DIMENSIONS			
SYMBOL	mm		
	MIN	NOM	MAX
A	2.20	2.30	2.38
A1	0.00	—	0.20
A2	0.97	1.07	1.17
b	0.68	0.78	0.90
b3	5.20	5.33	5.46
c	0.43	0.53	0.61
D	5.98	6.10	6.22
D1	5.30REF		
E	6.40	6.60	6.73
E1	4.63	—	—
e	2.286BSC		
H	9.40	10.10	10.50
L	1.38	1.50	1.75
L1	2.90REF		
L2	0.51BSC		
L3	0.88	—	1.28
L4	0.50	—	1.00
L5	1.65	1.80	1.95
θ	0°	—	8°

**TO-252 Part Marking Information**

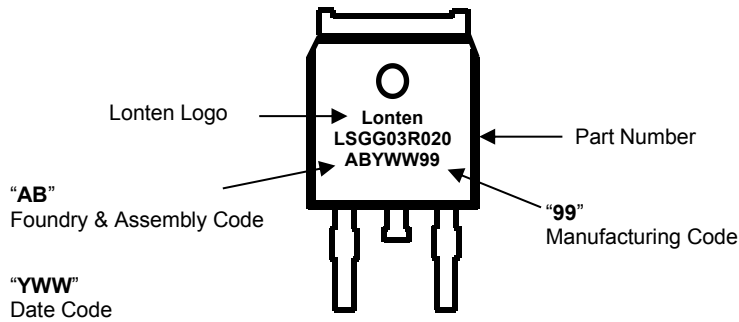

Calendar Year	Year Code	Calendar Week	Week Code
2018	G	Workweek 01	01
2019	H	Workweek 02	02
2020	I	Workweek 03	03
2021	J	Workweek 04	04
2022	K	Workweek 05	05
2023	L	Workweek 06	06
2024	M	.....	.....

## Mechanical Dimensions for TO-220

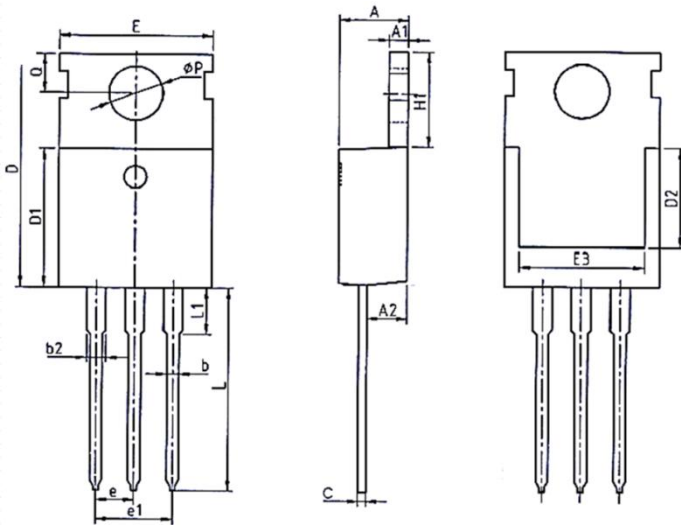

SYMBOL	COMMON DIMENSIONS					
	MM			INCH		
	MIN	NOM	MAX	MIN	NOM	MAX
A	4.37	4.57	4.70	0.172	0.180	0.185
A1	1.25	1.30	1.40	0.049	0.051	0.055
A2	2.20	2.40	2.60	0.087	0.094	0.102
b	0.70	0.80	0.95	0.028	0.031	0.037
b2	1.17	1.27	1.47	0.046	0.050	0.058
c	0.45	0.50	0.60	0.018	0.020	0.024
D	15.10	15.60	16.10	0.594	0.614	0.634
D1	8.80	9.10	9.40	0.346	0.358	0.370
D2	5.50	-	-	0.217	-	-
E	9.70	10.00	10.30	0.382	0.394	0.406
E3	7.00	-	-	0.276	-	-
e	2.54BCS			0.1BSC		
e1	5.08BCS			0.2REF		
H1	6.25	6.50	6.85	0.246	0.256	0.270
L	12.75	13.50	13.80	0.502	0.531	0.543
L1	-	3.10	3.40	-	0.122	0.134
ØP	3.40	3.60	3.80	0.134	0.142	0.150
Q	2.60	2.80	3.00	0.102	0.110	0.118

## TO-220 Part Marking Information

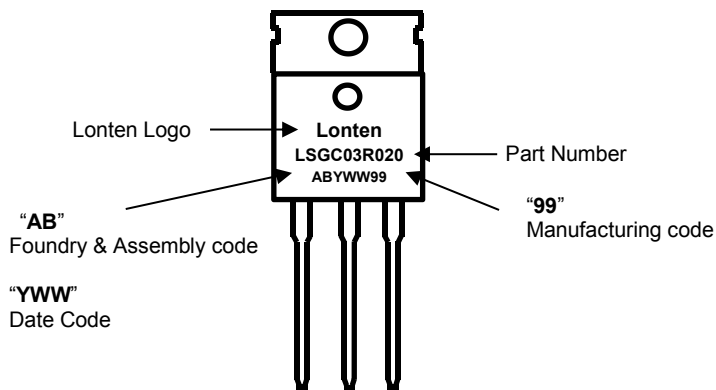

Calendar Year	Year Code	Calendar Week	Week Code
2018	G	Workweek 01	01
2019	H	Workweek 02	02
2020	I	Workweek 03	03
2021	J	Workweek 04	04
2022	K	Workweek 05	05
2023	L	Workweek 06	06
2024	M	.....	.....



---

**Disclaimer**

The content specified herein is for the purpose of introducing LONTEN's products (hereinafter "Products"). The information given in this document shall in no event be regarded as a guarantee of conditions or characteristics. Examples of application circuits, circuit constants and any other information contained herein illustrate the standard usage and operations of the Products. The peripheral conditions must be taken into account when designing circuits for mass production.

LONTEN does not assume any liability for infringement of patents, copyrights, or other intellectual property rights of third parties by or arising from the use of the Products or technical information described in this document.

The Products are not designed or manufactured to be used with any equipment, device or system which requires an extremely high level of reliability the failure or malfunction of which may result in a direct threat to human life or create a risk of human injury (such as a medical instrument, transportation equipment, aerospace machinery, nuclear-reactor controller, fuel-controller or other safety device). LONTEN shall bear no responsibility in any way for use of any of the Products for the above special purposes.

Although LONTEN endeavors to improve the quality and reliability of its products, semiconductor products have specific characteristics such as the occurrence of failure at a certain rate and malfunctions under certain use conditions. Please be sure to implement safety measures to guard them against the possibility of physical injury, and injury or damage caused by fire in the event of the failure of a LONTEN product.

The content specified herein is subject to change for improvement without notice. When using a LONTEN product, be sure to obtain the latest specifications.

## X-ON Electronics

Largest Supplier of Electrical and Electronic Components

*Click to view similar products for [MOSFET](#) category:*

*Click to view products by [Lonten Semiconductor](#) manufacturer:*

Other Similar products are found below :

[IRFD120](#) [JANTX2N5237](#) [BUK455-60A/B](#) [MIC4420CM-TR](#) [VN1206L](#) [NDP4060](#) [SI4482DY](#) [IPS70R2K0CEAKMA1](#) [SQD23N06-31L-GE3](#)  
[TK16J60W,S1VQ\(O](#) [2SK2614\(TE16L1,Q\)](#) [DMN1017UCP3-7](#) [DMN1053UCP4-7](#) [SQJ469EP-T1-GE3](#) [NTE2384](#) [DMC2700UDMQ-7](#)  
[DMN2080UCB4-7](#) [DMN61D9UWQ-13](#) [US6M2GTR](#) [DMN31D5UDJ-7](#) [DMP22D4UFO-7B](#) [DMN1006UCA6-7](#) [DMN16M9UCA6-7](#)  
[STF5N65M6](#) [IRF40H233XTMA1](#) [STU5N65M6](#) [DMN6022SSD-13](#) [DMN13M9UCA6-7](#) [DMTH10H4M6SPS-13](#) [DMN2990UFB-7B](#)  
[IPB80P04P405ATMA2](#) [2N7002W-G](#) [MCAC30N06Y-TP](#) [MCQ7328-TP](#) [NTMC083NP10M5L](#) [BXP7N65D](#) [BXP4N65F](#) [AOL1454G](#)  
[WMJ80N60C4](#) [BXP2N20L](#) [BXP2N65D](#) [BXT1150N10J](#) [BXT1700P06M](#) [TSM60NB380CP](#) [ROG](#) [RQ7L055BGTGR](#) [DMNH15H110SK3-13](#)  
[SLF10N65ABV2](#) [BSO203SP](#) [BSO211P](#) [IPA60R230P6](#)