

REV.	ECR/N NO./DESCRIPTION	DATE	DRAWN	CHECKED	APPROVE
8	SN13155	08/29'13	SKY	Vito	Barney
8A	SN130**	11/22'13	SKY	Vito	Barney
8B	SN150**	06/24'15	Vito		Barney

NOTES:

1. MATERIAL:

- 1). HOUSING: LCP, UL-94V0, BLACK.
- 2). COVER: LCP, UL-94V0, BLACK.
- 3). CONTACT: Phosphor Bronze.

2. FINISH: SEE TABLE

3. RoHS COMPLIANT. HF COMPLIANT

4. ELECTRICAL PERFORMANCE

- Contact resistance: 30mΩ MAX.
- Insulation resistance: 1000MΩ MIN

5. MECHANICAL PERFORMANCE

- Durability: 25 cycles

6. IR REFLOW TEMPERATURE: 260°C +/- 5 °C FOR 10 SECONDS MAX.

7. PRODUCT NUMBER NOTE:

ACA-SPI-***-***

- _____ TYPE SERIAL NUMBER
- _____ K: LEAD FREE/P: HALOGEN FREE
- _____ PRODUCT SERIAL NUMBER
- _____ PRODUCT TYPE
- _____ FINISHED PRODUCT
- _____ WAFER CONNECTOR
- _____ CONNECTOR

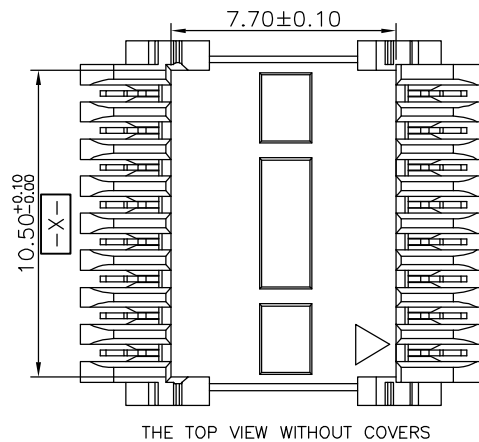
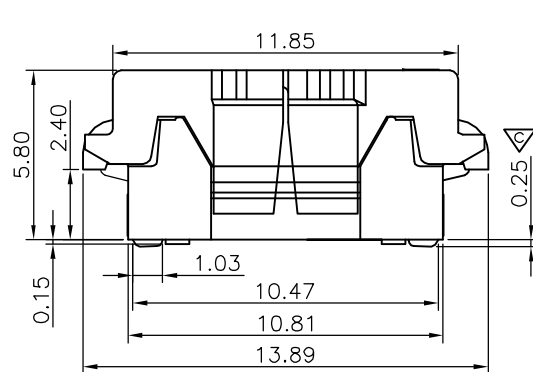
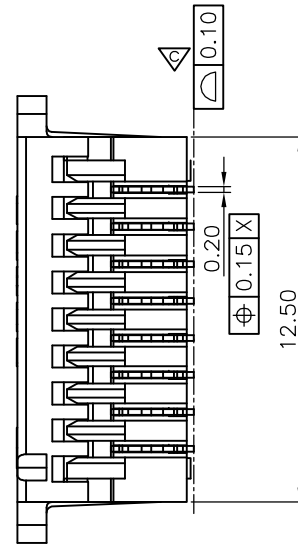
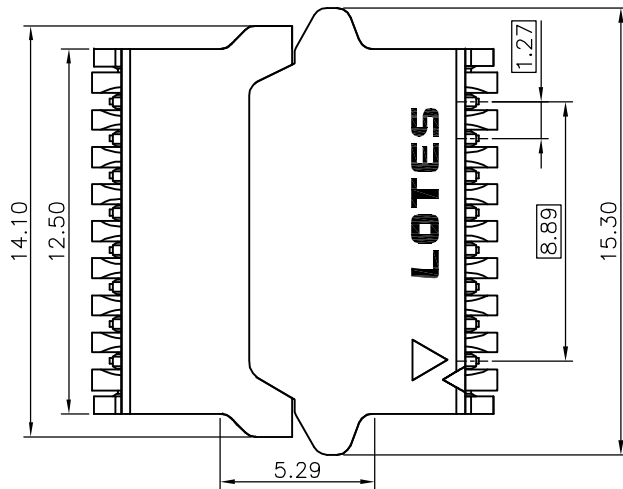
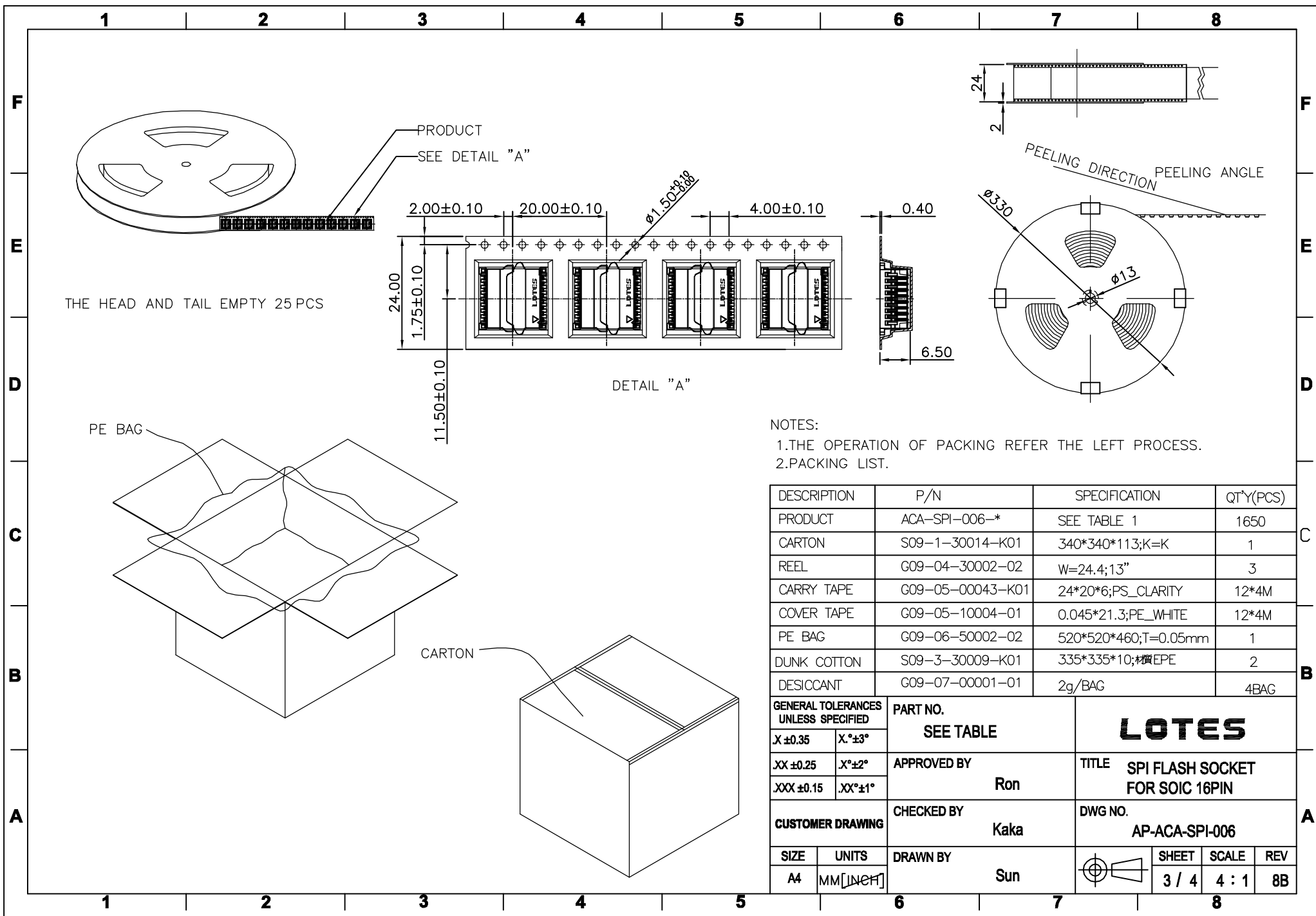

TABLE 1

NO.	PART NO.	DESCRIPTION
1	ACA-SPI-006-K01	Ni 50u" MIN, G/F 1 u" min
GENERAL TOLERANCES UNLESS SPECIFIED		LOTES
X ±0.35	X° ±3°	
XX ±0.25	X° ±2°	
XXX ±0.15	.XX° ±1°	
CUSTOMER DRAWING		DWG NO.
APPROVED BY		TITLE
CHECKED BY		
SIZE	UNITS	DRAWN BY
A4	MM [INCH]	Sun
		SHEET
		SCALE
		REV
		1 / 4
		4 : 1
		8B



NOTES:
 1.THE OPERATION OF PACKING REFER THE LEFT PROCESS.
 2.PACKING LIST.

DESCRIPTION	P/N	SPECIFICATION	QT*Y(PCS)
PRODUCT	ACA-SPI-006-*	SEE TABLE 1	1650
CARTON	S09-1-30014-K01	340*340*113;K=K	1
REEL	G09-04-30002-02	W=24.4;13"	3
CARRY TAPE	G09-05-00043-K01	24*20*6;PS_CLARITY	12*4M
COVER TAPE	G09-05-10004-01	0.045*21.3;PE_WHITE	12*4M
PE BAG	G09-06-50002-02	520*520*460;T=0.05mm	1
DUNK COTTON	S09-3-30009-K01	335*335*10;材质EPE	2
DESICCANT	G09-07-00001-01	2g/BAG	4BAG

GENERAL TOLERANCES UNLESS SPECIFIED		PART NO.	LOTES
X ±0.35	X° ±3°	SEE TABLE	
XX ±0.25	X° ±2°	APPROVED BY	TITLE
XXX ±0.15	.XX° ±1°	Ron	SPI FLASH SOCKET FOR SOIC 16PIN
CUSTOMER DRAWING		CHECKED BY	DWG NO.
		Kaka	AP-ACA-SPI-006
SIZE	UNITS	DRAWN BY	
A4	MM [INCH]	Sun	
			SHEET
			3 / 4
			SCALE
			4 : 1
			REV
			8B

1

2

3

4

5

6

7

8

F

F

E

E

D

D

PATR NUMBER	SPECIFICATION	STORAGE TEMPERATURE	STORAGE TEMPERATURE
ACA-SPI-006-K01	SPI FLASH SOCKET FOR SOIC 16PIN	15°C~35°C	HR 45%~75%

C

C

B

B

A

A

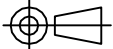
GENERAL TOLERANCES UNLESS SPECIFIED		PART NO. SEE TABLE	LOTES			
X ±0.35	X.°±3°					
.XX ±0.25	.X°±2°		APPROVED BY Ron	TITLE SPI FLASH SOCKET FOR SOIC 16PIN		
.XXX ±0.15	.XX°±1°	CHECKED BY Kaka	DWG NO. AP-ACA-SPI-006			
CUSTOMER DRAWING		DRAWN BY Sun		SHEET	SCALE	REV
SIZE A4	UNITS MM [INCH]			4 / 4	4 : 1	8B

1

2

3

4

5

6

7

8

X-ON Electronics

Largest Supplier of Electrical and Electronic Components

Click to view similar products for [Emulators/Simulators](#) category:

Click to view products by [LOTES](#) manufacturer:

Other Similar products are found below :

[QB-78K0RKE3L-TB](#) [JX040102-1](#) [ST7MDT2-EMU2B](#) [FU6522L](#) [ACA-SPI-006-K01](#) [QB-78K0RKG3-TB](#) [7027-D-350](#) [QB-78K0KF2-TB](#) [J-Link ULTRA+](#) [CE118M12](#) [BH-POE-KIT-1](#) [BH-USB-100v2-ARM](#) [BH-USB-100v2D](#) [BH-USB-200](#) [BH-USB-560v2](#) [BH-XDS-560v2](#) [BH-XDS-560v2-BP](#) [S5U1C17001H3100](#) [ECC111428EU](#) [IM1227](#) [IM1253B](#) [IM1259G](#) [IM1266](#) [IM1275](#) [Btip](#) [VisionSeed S1](#) [ACA-SPI-004-K02](#) [ACA-SPI-004-K01](#) [AC244002](#) [AC244063](#) [AC244064](#) [AC244065](#) [AC244066](#) [DV244140](#) [MKSDSOCKET-Pinboard V1](#) [CWH-UTP-ONCE-HE](#) [TMS320-XDS100-V2](#) [TMS320-XDS100-V3](#) [LDP-12-24DC-2833657](#) [QB-78K0KC2L-TB](#) [QB-78K0SKB1-TB](#) [RTE0T00020KCAC0000J](#) [RTE0T0002LKCE00000R](#) [114991468](#) [J-Link](#) [J-Link PRO](#) [TMDSEMU560V2STM-UE](#) [QB-78K0IB2-TB](#) [QB-78K0RIE3-TB](#) [Infrared Reflective Sensor](#)