



1A Single Chip Li-Ion and Li-Polymer Charger

General Description

The LP28013H is a complete constant-current/constant voltage linear charger for single cell lithium-ion battery. Its TDFN-10 package and low external component count make the LP28013H ideally suited for portable applications.

The charge current and termination current could program by external resistors. While the battery voltage is lower than 2.6V, the charge current is typically 10% of the programmed charge current. During the constant voltage phases, if the charge current reduces to the termination current level, the device will disable the internal power MOS and CHRG goes high impedance, which signals the charge cycle is termination.

When the input supply is removed, the LP28013H automatically enters a low current state, dropping the battery drain current to less than $1\mu A$.

Other features include charge current monitor, under voltage lockout, automatic recharge and a status pin to indicate charge termination and the presence of an input voltage.

Order Information

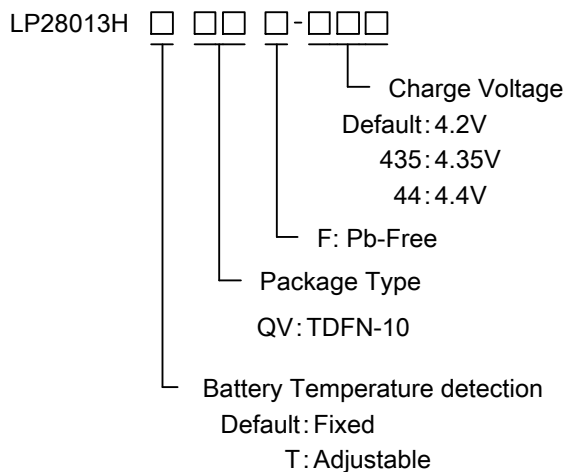

Features

- ◆ Input voltage up to 36V
- ◆ Input Over Voltage Protection : 6.3V
- ◆ Short-circuit protection
- ◆ Programmable Charge Current up to 1A
- ◆ $1\mu A$ Battery Reverse Current
- ◆ Protection of Reverse Connection of Battery
- ◆ No MOSFET, Sense Resistor or Blocking Diode Required
- ◆ Constant-Current/Constant-Voltage Operation with Thermal Regulation to Maximize Charge Rate Without Risk of Overheating
- ◆ TDFN-10 Package
- ◆ RoHS Compliant and 100% Lead (Pb)-Free

Applications

- ◇ Portable Media Players/Game
- ◇ Power Bank
- ◇ Bluetooth Applications
- ◇ PDA/MID



Marking Information

Device	Marking	Package	Shipping
LP28013HQVF	LPS LP28013H YWX	TDFN-10	5K/REEL
LP28013HQVF-435	LPS LP28013H 435YWX	TDFN-10	5K/REEL
LP28013HQVF-44	LPS LP28013H 44YWX	TDFN-10	5K/REEL

LP28013HTQVF	LPS LP28013HT YWX	TDFN-10	5K/REEL
LP28013HTQVF-435	LPS LP28013HT 435YWX	TDFN-10	5K/REEL
LP28013HTQVF-44	LPS LP28013HT 44YWX	TDFN-10	5K/REEL

Marking indication:
Y:Production year W:Production week X: Series Number

Typical Application Circuit

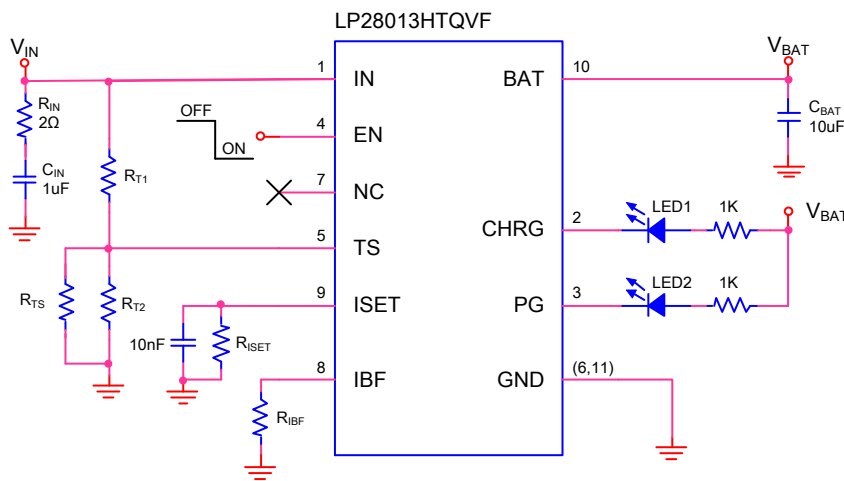
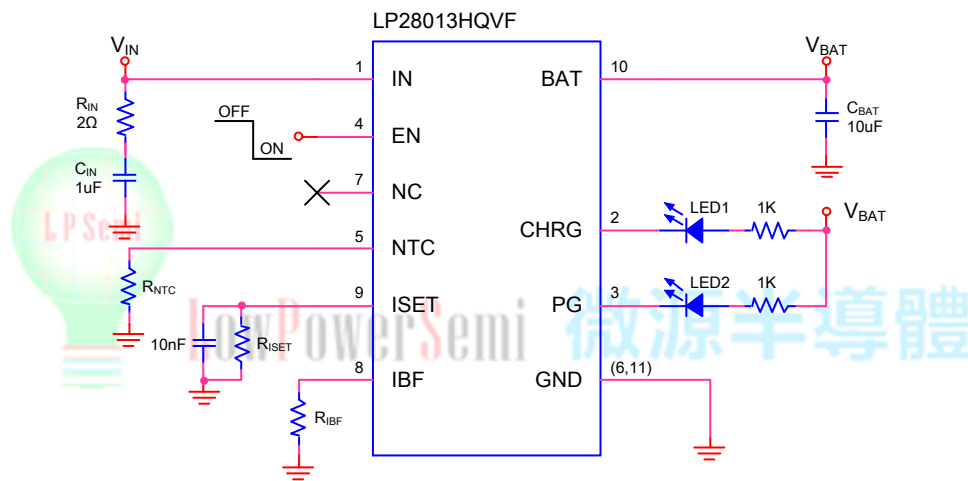



Functional Pin Description

Package Type	LP28013H	LP28013HT
Pin Configurations	<p>TDFN-10 (Top View)</p>	<p>TDFN-10 (Top View)</p>

Pin Description

Pin No.		Name	Description
28013HQVF	28013HTQVF		
1	1	IN	IN is the input power source. Connect to a wall adapter.
2	2	CHRG	Open-Drain Charge Status Output. When the battery is charging, the CHRG pin is pulled low by an internal NMOS. When the charge cycle is completed, the pin could be pulled High by an external pull high resistor.
3	3	PG	Open-Drain Status Output. Low indicates the input voltage is above UVLO and the OUT (battery) voltage
4	4	EN	Charge Enable Input (active low).
5	-	NTC	Negative Thermal Coefficient (NTC) Thermistor Pin.
-	5	TS	Temperature detection pin
6	6	GND	GND is the connection to system ground.
7	7	NC	No Connector.
8	8	IBF	Charge Status Threshold Program. Connect this pin to an external resistor to program the charge termination current.
9	9	ISET	Charge Current Program. The charge current is programmed by connecting a 1% resistor (R_{ISET}) to ground.
10	10	BAT	BAT is the connection to the battery. Typically a 10 μ F capacitor is needed.
11(PAD)	11(PAD)	GND	Ground.



Functional Block Diagram

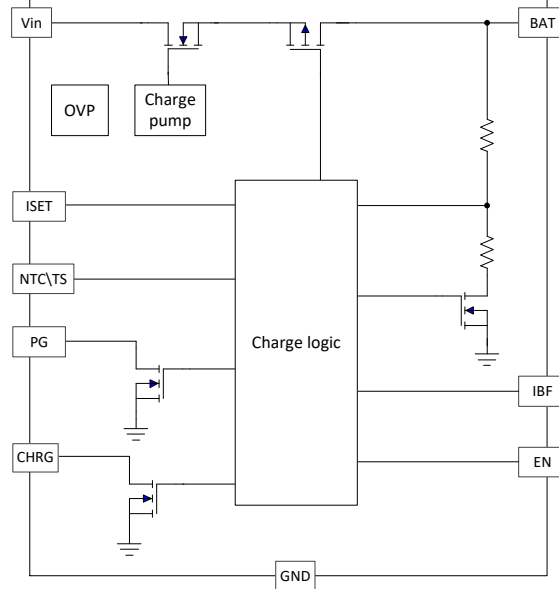

Absolute Maximum Ratings ^{Note 1}

- ◇ IN to GND ----- -0.3V to 36V
- ◇ BAT to GND ----- -5V to 20V
- ◇ Other Pin to GND ----- -0.3V to 6.5V
- ◇ Maximum Junction Temperature(T_J) ----- 125°C
- ◇ Storage Temperature ----- -55°C to 150°C

Note 1. Stresses beyond those listed under “Absolute Maximum Ratings” may cause permanent damage to the device. These are stress ratings only, and functional operation of the device at these or any other conditions beyond those indicated in the operational sections of the specifications is not implied. Exposure to absolute maximum rating conditions for extended periods may affect device reliability.

Thermal Information

- ◇ Maximum Power Dissipation (P_D , $T_A=25^\circ\text{C}$) ----- 1.5W
- ◇ Thermal Resistance (θ_{JA}) ----- 65°C/W

ESD Susceptibility

- ◇ HBM(Human Body Model) ----- 2KV
- ◇ MM(Machine Model) ----- 200V

Recommended Operating Conditions

- ◇ Input supply voltage ----- 4.5V to 5.8V
- ◇ Operating Ambient Temperature Range ----- -40°C to 85°C



Electrical Characteristics

(The specifications which apply over the full operating temperature range, otherwise specifications are at $T_A=25^{\circ}\text{C}$, $V_{\text{IN}} = 5\text{V}$, unless otherwise noted.)

Symbol	Parameter	Condition	Min	Typ.	Max	Units
I_{IN}	Input Supply Current			280		μA
$V_{\text{EN_ON}}$	EN Logic-Low Voltage Threshold				0.4	V
$V_{\text{EN_OFF}}$	EN Logic-High Voltage Threshold		1.4			V
V_{FLOAT}	Regulated Output (Float) Voltage	LP28013HQVF LP28013HTQVF	4.158	4.2	4.242	V
		LP28013HQVF-435 LP28013HTQVF-435	4.307	4.35	4.3935	V
		LP28013HQVF-44 LP28013HTQVF-44	4.356	4.4	4.444	V
V_{UVLO}	V_{IN} Under Voltage Lockout Threshold			3.3		V
$V_{\text{UV_HYS}}$	V_{IN} Under Voltage Lockout Hysteresis			170		mV
V_{OVP}	Input Voltage OVP			6.3		V
$V_{\text{OVP_HYS}}$	OVP Hysteresis			300		mV
I_{BAT}	BAT Pin Current	$R_{\text{ISET}}=1.8\text{k}$, Current Mode	900	1000	1100	mA
		$R_{\text{ISET}}=3.6\text{k}$, Current Mode	450	500	550	mA
		$V_{\text{BAT}}=4.2\text{V}$, $V_{\text{IN}}=\text{Float}$		0.1		μA
I_{TRIKL}	Trickle Charge Current	$V_{\text{BAT}} < V_{\text{TRIKL}}$, $R_{\text{ISET}}=1.8\text{k}$, Current Mode		10		$I_{\text{BAT}}\%$
V_{TRIKL}	Trickle Charge Threshold Voltage	V_{BAT} Rising		2.6		V
$V_{\text{TR_HYS}}$	Trickle Charge Hysteresis Voltage			150		mV
V_{ISET}	ISET Pin Voltage	$R_{\text{ISET}}=18\text{k}$, Current Mode		1		V
I_{STAT}	CHRG/PG Pin Sink Current	$V_{\text{STAT}}=5\text{V}$			5	μA
V_{STAT}	CHRG/PG Pin Output Low Voltage	$I_{\text{STAT}}=5\text{mA}$			0.5	V
ΔV_{RESTAT}	Recharge Battery Threshold Voltage	$V_{\text{FLOAT}}-V_{\text{RESTAT}}$		150		mV
T_{LIM}	Junction Temperature in Thermal Protection			125		$^{\circ}\text{C}$
V_{NTC_0}	Low Temperature Disable Voltage Threshold	LP28013HQVF		1.15		V
$V_{\text{NTC}_{10}}$	Half Charging Current Mode Voltage Threshold (Low temperature)	LP28013HQVF		0.75		V
$V_{\text{NTC}_{60}}$	High Temperature Disable Voltage Threshold	LP28013HQVF		0.19		V
$V_{\text{NTC_HYS}}$	NTC Hysteresis	LP28013HQVF		30		mV
I_{NTC}	NTC Bias Current	LP28013HQVF, NTC=10K		48		μA
$V_{\text{TS_H}}$	TS high voltage thresholds	LP28013HTQVF		60		$\%V_{\text{IN}}$
$V_{\text{TS_L}}$	TS low voltage thresholds	LP28013HTQVF		30		$\%V_{\text{IN}}$
$V_{\text{TS_HYS}}$	TS voltage hysteresis	LP28013HTQVF		30		mV



Typical Performance Characteristics

($C_{IN}=C_{OUT}=10\mu F$, $R_{ISET}=16.5K$, $V_{FLOAT}=4.2V$, unless otherwise noted)

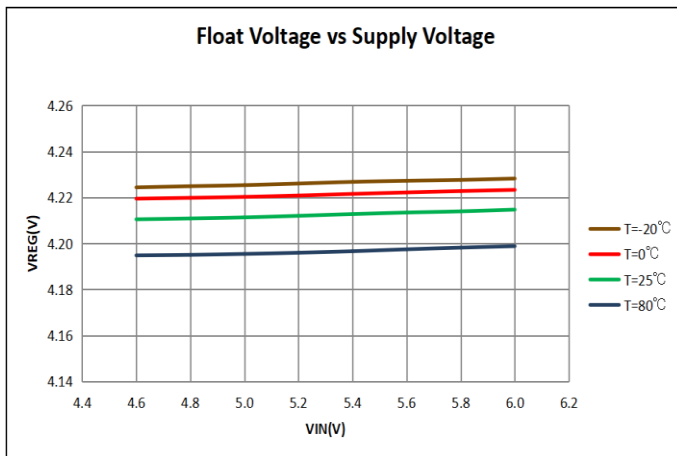
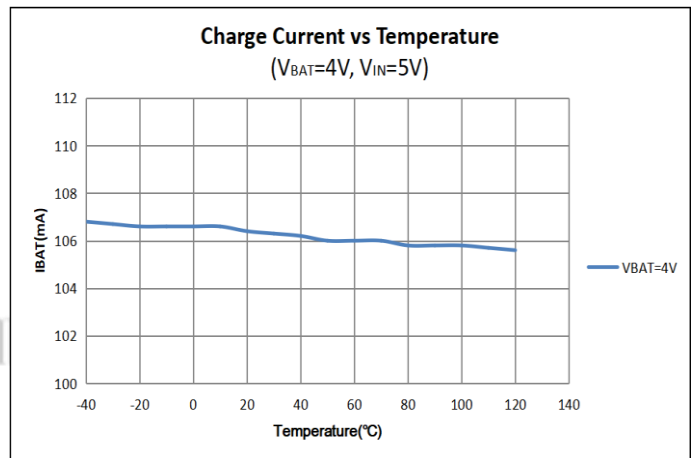
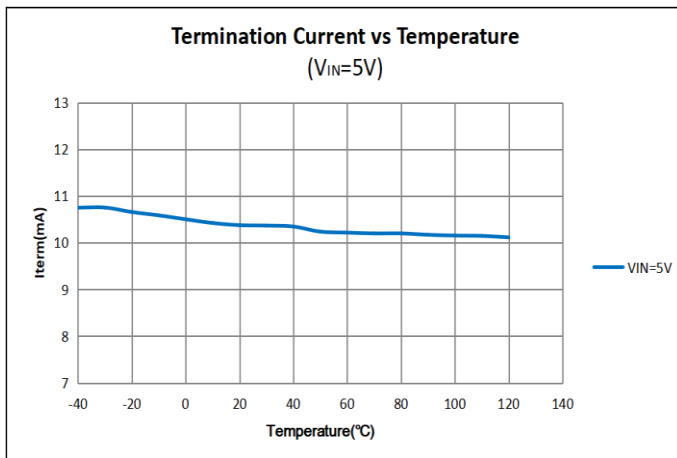
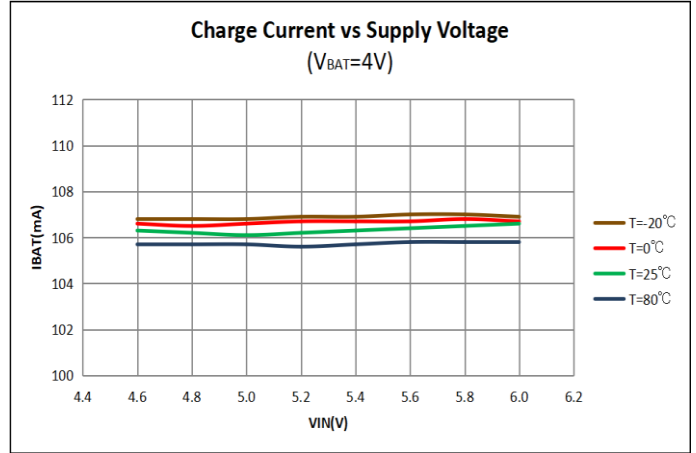
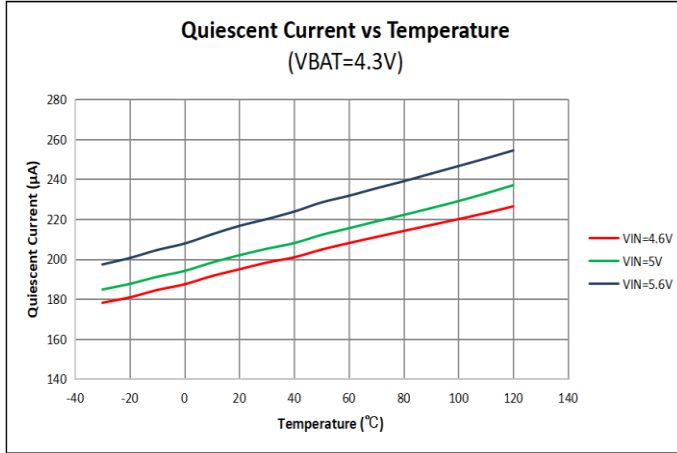



Application Information

The LP28013H has built-in input voltage surge protection as high as +36V. The charger IC will be automatically disabled when the input voltage is lower than 3.3V or higher than 6.3V. The open-drain PG Pin is used to indicate an input power good condition ($3.3V < V_{IN} < 6.3V$). If the input voltage is lower than the battery voltage, the IC is also disabled to prevent the battery from draining.

A charge cycle begins when the voltage at the VIN pin rises above the UVLO threshold level, when a battery is connected to the charger output. If the BAT pin is less than 2.6V, the charger enters trickle charge mode. In this mode, the LP28013H supplies approximately 1/10 the ISET programmed charge current to bring the battery voltage up to a safe level for full current charging. When the BAT pin voltage rises above 2.6V, the charger enters constant-current mode (CC), where the ISET programmed charge current is supplied to the battery. When the BAT pin approaches the final float voltage, the LP28013H enters constant-voltage mode (CV) and the charge current begins to decrease, and the battery full indication is set when the charge current in the CV mode is reduced to the full battery current (default 10% charge current or programmed by R_{IBF}).

Charge Current Program

The charge current (I_{BAT}) is set by a resistor (R_{ISET}) connecting from the ISET pin to GND. The relationship of the charge current and the programming resistance is established by the following formula

$$I_{BAT} = \frac{V_{ISET} \times 1800}{R_{ISET}}$$

Termination Charge Current Program

The battery charge Termination current threshold (I_{BF}) is programmed by connecting a resistor R_{IBF} from the I_{BF} pin to GND:

$$I_{BF} = \frac{R_{ISET} \times I_{BAT}}{R_{IBF}}$$

Battery Temperature Detection (LP28013HQVF)

The NTC function for the LP28013H is designed to follow the new JEITA temperature standard for Li-Ion. There are now three thresholds, 60°C, 10°C, and 0°C. Normal operation occurs between 10°C and 60°C. If between 0°C and 10°C the charge current level is cut in half. Above 60°C or below 0°C the charge is disabled.

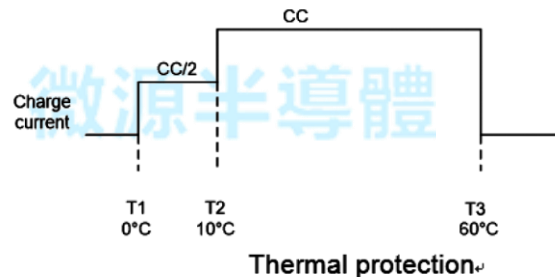

The NTC feature is implemented using an internal 48µA current source to bias the thermistor connected from the NTC terminal to GND (designed for use with a 10k NTC $\beta=3370$ [SEMITEC 103AT-2 or Mitsubishi TH05-3H103F]). If NTC feature is not needed, a fixed 10kΩ can be placed between NTC and GND to allow normal operation. Since the I_{NTC} current is fixed along with the temperature thresholds, it is not possible to use thermistor values other than the 10k NTC (at 25°C).



(LP28013HTQVF)

An internal resistor divider sets the low temperature threshold (V_{TS_L}) and high temperature threshold (V_{TS_H}) at 60% of V_{IN} and 30% of V_{IN} , respectively. For a given TS thermistor, select an appropriate R_{T1} and R_{T2} to set the TS window with following equation:

$$\frac{V_{TS_L}}{V_{IN}} = \frac{R_{T2} \parallel R_{TS_COLD}}{R_{T1} + R_{T2} \parallel R_{TS_COLD}} = T_L = 60\%$$

$$\frac{V_{TS_H}}{V_{IN}} = \frac{R_{T2} \parallel R_{TS_HOT}}{R_{T1} + R_{T2} \parallel R_{TS_HOT}} = T_H = 30\%$$

Where R_{TS_HOT} is the value of the TS resistor at the upper bound of its operating temperature range, and R_{TS_COLD} is its lower bound. The two resistors R_{T1} and R_{T2} determine the upper and lower temperature limits independently. This flexibility allows the IC to operate with most TS resistors for different temperature range requirements. Calculate R_{T1} and R_{T2} with following equation:

$$R_{T1} = \frac{R_{TS_HOT} \times R_{TS_COLD} \times (T_L - T_H)}{T_H \times T_L \times (R_{TS_COLD} - R_{TS_HOT})}$$

$$R_{T2} = \frac{R_{TS_HOT} \times R_{TS_COLD} \times (T_L - T_H)}{(1 - T_L) \times T_H \times R_{TS_COLD} - (1 - T_H) \times T_L \times R_{TS_HOT}}$$

Automatic Recharge

Once the charge cycle is terminated, the LP28013H continuously monitors the voltage on the BAT pin. A charge cycle restarts when the battery voltage falls below V_{RECHRG} (which corresponds to approximately 80% to 90% battery capacity). This ensures that the battery is kept at or near a fully charged condition and eliminates the need for periodic charge cycle initiations.

Enable Function

The LP28013H features an enable/disable function. An input “Low” signal at EN pin or if this pin is floating will enable the IC. To assure the charger will switch ON, the EN turn on control level must below 0.4V. The charger IC will go into the shutdown mode when the voltage on the EN pin is greater than 1.4V. If the enable function is not needed in a specific application, it may be tied to GND or floating to keep the charge IC in a continuously on state.

Charge Status Indicator (CHAG & PG)

After application of a 5V source, the input voltage rises above the UVLO and sleep thresholds ($V_{IN} > V_{BAT} + V_{DT}$), but is less than OVP ($V_{IN} < V_{OVP}$), then the PG turns on and provides a low impedance path to ground.

CHRG has two different states: strong pull-down (~5mA) and high impedance. The strong pull-down state indicates that the LP28013H is in a charge cycle. When the charger is entered CV mode and once the charge current has reduced to the battery full charge current threshold (I_{BF}), the CHRG pin will become high impedance.

Function	CHRG
Charging	Low
Charge Finish	Hi-Z

Function	PG
$V_{IN} < V_{UVLO}$	Hi-Z
$V_{UVLO} < V_{IN} < V_{OVP}$	Low
$V_{OVP} < V_{IN}$	Hi-Z



Thermal Limiting

An internal thermal feedback loop reduces charge current if the die temperature attempts to rise above a preset value of approximately 125°C. This feature protects the LP28013H from excessive temperature and allows the user to push the limits of the power handling capability of a given circuit board without risk of damaging the LP28013H. The charge current can be set according to typical (not worst-case) ambient temperature with the assurance that the charger will automatically reduce the current in worst-case conditions.

Power Dissipation

The conditions that cause the LP28013H to reduce charge current through thermal feedback can be approximated by considering the power dissipated in the IC. Nearly all of this power dissipation is generated by the internal MOSFET calculated to be approximately:

$$P_D = (V_{IN} - V_{BAT}) \times I_{BAT}$$

Where P_D is the power dissipated, V_{IN} is the input supply voltage, V_{BAT} is the battery voltage and I_{BAT} is the charge current. The approximate ambient temperature at which the thermal feedback begins to protect the IC is:

$$T_A = 125^\circ\text{C} - P_D \times \theta_{JA}$$





Packaging Information

TDFN-10(3*3)

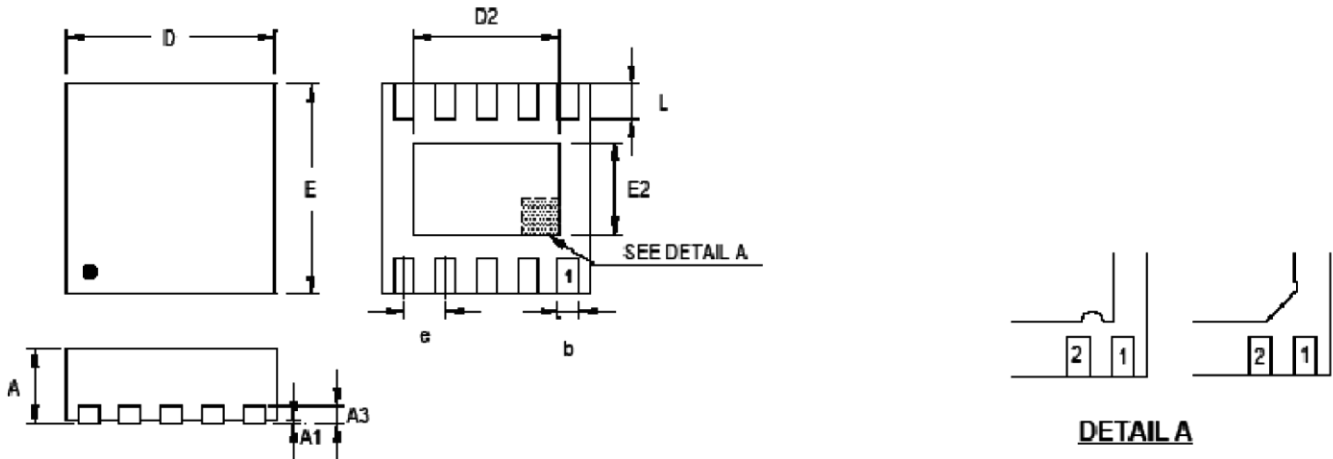

Pin #1 ID and Tie Bar Mark Options

Note : The configuration of the Pin #1 identifier is optional, but must be located within the zone indicated.

Symbol	Dimensions in millimeters		Dimensions in inches	
	Min	Max	Min	Max
A	0.700	0.800	0.028	0.031
A1	0.000	0.050	0.000	0.002
A3	0.175	0.250	0.007	0.010
b	0.180	0.300	0.007	0.012
D	2.950	3.050	0.116	0.120
D2	2.300	2.650	0.091	0.104
E	2.950	3.050	0.116	0.120
E2	1.500	1.750	0.059	0.069
e	0.500		0.020	
L	0.350	0.450	0.014	0.018

X-ON Electronics

Largest Supplier of Electrical and Electronic Components

Click to view similar products for [Battery Management](#) category:

Click to view products by [LOWPOWER](#) manufacturer:

Other Similar products are found below :

[VN5R003HTR-E](#) [NCP1851BFCCT1G](#) [NCP1855FCCT1G](#) [FAN54063UCX](#) [LC05132C01NMTTGTG](#) [ISL78714ANZ](#) [CM1104-EH](#) [CM1104-DBB](#) [CM1104-MBB](#) [XC6801A421MR-G](#) [ISL95521BHRZ](#) [ISL95521BIRZ](#) [MP2639AGR-P](#) [S-82D1AAE-A8T2U7](#) [S-82D1AAA-A8T2U7](#) [S-8224ABA-I8T1U](#) [MC33772CTC0AE](#) [BQ28Z610DRZR-R1](#) [MCP73832-4ADI/MC](#) [MCP73832T-2DCIMC](#) [MCP73833T-AMIMF](#) [MCP73833T-AMI/UN](#) [MCP73838-NVI/MF](#) [MCP73213-A6BI/MF](#) [MCP73831-2ACI/MC](#) [MCP73831T-2ATIMC](#) [MCP73832-2ACI/MC](#) [MCP73832T-3ACIMC](#) [MCP73833T-FCI/MF](#) [MCP73853-IML](#) [BQ25895RTWR](#) [BQ29704DSER](#) [BQ78Z100DRZR](#) [ISL78610ANZ](#) [FAN5403UCX](#) [NCP367DPMUECTBG](#) [FAN54015BUCX](#) [MAX8934BETI+](#) [BQ24311DSGR](#) [BQ25100HYFPR](#) [BQ29707DSER](#) [MAX17048G+T10](#) [BQ24130RHRLR](#) [BQ25120AYFPR](#) [BQ29703DSER](#) [BQ771807DPJR](#) [BQ25120AYFPT](#) [MAX17055ETB+T](#) [MAX17710GB+T](#) [MAX14634EWC+](#)