



# 1A Single Chip Li-Ion and Li-Polymer Charger

## General Description

The LP28014 is a complete constant-current/ constant voltage linear charger for single cell lithium-ion battery. Its TDFN-8 package and low external component count make the LP28014 ideally suited for portable applications. No external sense resistor is needed, and no blocking diode is required due to the internal MOSFET architecture. Thermal feedback regulates the charge current to limit the die temperature during high power operation or high ambient temperature. The charge voltage is fixed at 4.2V, and the charge current can be ISET programmed externally with a single resistor.

When the input supply is removed, the LP28014 automatically enters a low current state, dropping the battery drain current to less than < 1µA.

Other features include charge current monitor, under voltage lockout, automatic recharge and a status pin to indicate charge termination and the presence of an input voltage.

## Features

- ◆ input voltage up to 28V
- ◆ input Over Voltage Protection : 7V
- ◆ Short-circuit protection
- ◆ Programmable Charge Current : 300mA to 1000mA
- ◆ < 1µA Battery Reverse Current
- ◆ Protection of Reverse Connection of Battery
- ◆ No MOSFET, Sense Resistor or Blocking Diode Required
- ◆ Constant-Current/Constant-Voltage Operation with Thermal Regulation to Maximize Charge Rate Without Risk of Overheating
- ◆ TDFN-8 2mmx2mm Package
- ◆ RoHS Compliant and 100% Lead (Pb)-Free

## Order Information

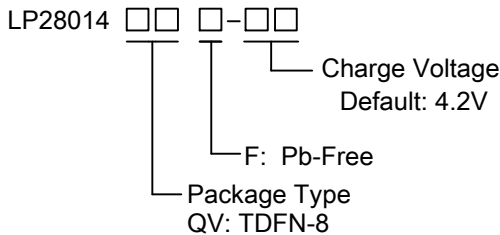

## Applications

- ✧ Portable Media Players/Game
- ✧ Power Bank
- ✧ Bluetooth Applications
- ✧ PDA/MID

## Typical Application Circuit

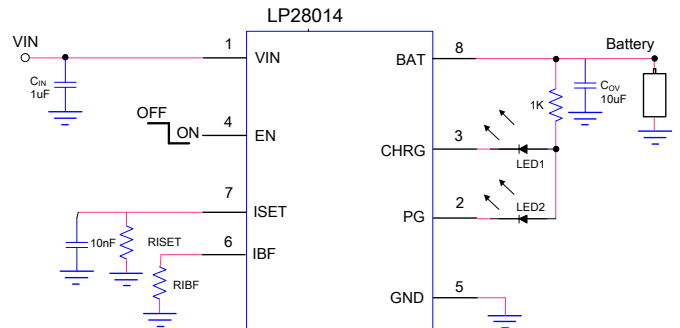

## Marking Information

Device	Marking	Package	Shipping
LP28014QVF	LPS P28014 YWX	TDFN-8	4K/REEL
Marking indication: Y:Production year W:Production week X: Series Number			



## Functional Pin Description

Package Type	Pin Configurations
TDFN-8	

## Pin Description

PIN No.	PIN NAME	DESCRIPTION
1	VIN	VIN is the input power source. Connect to a wall adapter.
2	PG	Open-Drain Status Output. Low indicates the input voltage is above UVLO and the OUT (battery) voltage.
3	CHRG	Open-Drain Charge Status Output. When the battery is charging, the CHRG pin is pulled low by an internal NMOS. When the charge cycle is completed, the pin could be pulled High by an external pull high resistor.
4	EN	Charge Enable Input (active low).
5	GND	GND is the connection to system ground.
6	IBF	Charge Status Threshold Program. Connect this pin to an external resistor to program the charge termination current.
7	ISET	Charge Current Program. The charge current is programmed by connecting a 1% resistor( $R_{ISET}$ ) to ground.
8	BAT	BAT is the connection to the battery. Typically a 10 $\mu$ F Tantalum capacitor is needed for stability when there is no battery attached. When a battery is attached, only a 1 $\mu$ F ceramic capacitor is required.



## Function Block Diagram

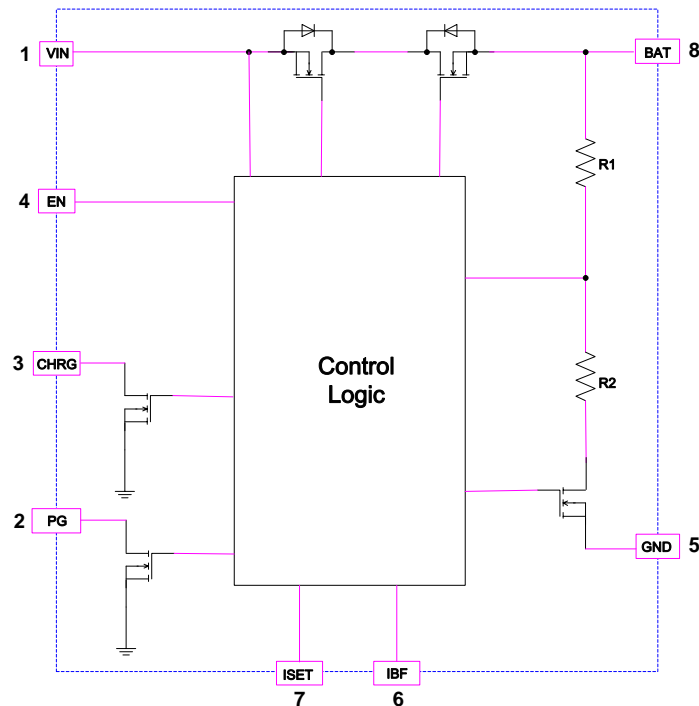

## Absolute Maximum Ratings <sup>Note 1</sup>

- ◇ Input Voltage to GND ----- -0.3V to 28V
- ◇ BAT voltage GND ----- - 5V to 7V
- ◇ Other pin to GND ----- -0.3V to 6.5V
- ◇ Output current----- 1200mA
- ◇ Maximum Junction Temperature ----- 125°C
- ◇ Maximum Soldering Temperature (at leads, 10 sec) ----- 260°C
- ◇ Storage Temperature ----- -55°C to 150°C

## Thermal Information

- ◇ Thermal Resistance ( $\theta_{JA}$ ) ----- 76°C/W

## ESD Susceptibility

- ◇ HBM(Human Body Mode) ----- 2KV
- ◇ MM(Machine Mode) ----- 200V

**Note 1.** Stresses beyond those listed under “Absolute Maximum Ratings” may cause permanent damage to the device. These are stress ratings only, and functional operation of the device at these or any other conditions beyond those indicated in the operational sections of the specifications is not implied. Exposure to absolute maximum rating conditions for extended periods may affect device reliability.

## Recommended Operating Conditions

- ◇ Input supply voltage ----- 4.5V to 6.5V
- ◇ Operating Ambient Temperature Range----- -40°C to 85°C



## Electrical Characteristics

( $T_A = 25^\circ\text{C}$ .  $V_{IN} = 5\text{V}$ , unless otherwise noted.)

SYMBOL	PARAMETER	CONDITIONS	MIN	TYP.	MAX	UNITS
$I_{IN}$	Input Supply Current			1000		$\mu\text{A}$
$V_{EN\_ON}$	EN Logic-Low Voltage Threshold				0.4	V
$V_{EN\_OFF}$	EN Logic-High Voltage Threshold		1.4			V
$V_{FLOAT}$	Regulated Output (Float) Voltage	LP28014QVF	4.158	4.2	4.242	V
$V_{UV}$	$V_{IN}$ Under voltage Lockout Threshold	From $V_{IN}$ Low to High	3.1	3.3	3.5	V
$V_{UVHYS}$	$V_{IN}$ Under voltage Lockout Hysteresis			150		mV
$V_{OVP}$	Input Voltage OVP	$V_{IN}$ Rising	6.7	7	7.3	V
$V_{OVP-HYS}$	OVP Hysteresis			0.2		V
$I_{BAT}$	BAT Pin Current	$R_{ISET} = 1.5\text{k}$ , Current Mode	900	1000	1100	mA
		$R_{ISET} = 3\text{k}$ , Current Mode		500		mA
		$V_{BAT} = 4.2\text{V}$ , $V_{in} = \text{float}$		1		$\mu\text{A}$
$I_{TRIKL}$	Trickle Charge Current	$V_{BAT} < V_{TRIKL}$ , Current Mode		10		$\%I_{BAT}$
$V_{TRIKL}$	Trickle Charge Threshold Voltage	$V_{BAT}$ Rising		2.6		V
$V_{TRHYS}$	Trickle Charge Hysteresis Voltage			150		mV
$I_{BF}$	Battery Full Programming Range		10		50	$\%I_{BAT}$
$V_{ISET}$	ISET Pin Voltage	$R_{ISET} = 10\text{k}$ , Current Mode		1		V
$I_{STAT}$	CHRG/PG Pin Weak Pull-Down Current	$V_{STAT} = 5\text{V}$			5	$\mu\text{A}$
$V_{STAT}$	CHRG Pin Output Low Voltage	$I_{STAT} = 5\text{mA}$			0.1	V
$\Delta V_{RESTAT}$	Recharge Battery Threshold Voltage	$V_{FLOAT} - V_{RESTAT}$		150		mV
$T_{LIM}$	Junction Temperature in Thermal Protection			125		$^\circ\text{C}$



## Application Information

### Input Voltage Range

The LP28014 has built-in input voltage surge protection as high as +28V. The charger IC will be automatically disabled when the input voltage is lower than 3.3V or higher than 7.0V. The open-drain PG Pin is used to indicate an input power good condition ( $3.3V < V_{IN} < 7.0V$ ). If the input voltage is lower than the battery voltage, the IC is also disabled to prevent the battery from draining.

A charge cycle begins when the voltage at the VIN pin rises above the UVLO threshold level, when a battery is connected to the charger output. If the BAT pin is less than 2.6V, the charger enters trickle charge mode. In this mode, the LP28014 supplies approximately 1/10 the ISET programmed charge current to bring the battery voltage up to a safe level for full current charging. When the BAT pin voltage rises above 2.6V, the charger enters constant-current mode(CC), where the ISET programmed charge current is supplied to the battery. When the BAT pin approaches the final float voltage, the LP28014 enters constant-voltage mode(CV) and the charge current begins to decrease, and the battery full indication is set when the charge current in the CV mode is reduced to the programmed full battery current (IBF).

### ISET programming Charge Current

The charge current ( $I_{BAT}$ ) is set by a resistor ( $R_{ISET}$ ) connecting from the ISET pin to GND. The relationship of the charge current and the programming resistance is established by the following table.

$$I_{BAT}(mA) = V_{ISET} \times 1500 / R_{ISET}(K\Omega)$$

### Termination charge current programmed

The battery charge Termination current threshold (IBF) is programmed by connecting a resistor RBF from the IBF pin to GND:

$$I_{BF} = R_{ISET} \times I_{BAT} / R_{IBF}$$

### Automatic Recharge

Once the charge cycle is terminated, the LP28014 continuously monitors the voltage on the BAT pin. A charge cycle restarts when the battery voltage falls below 4.05V (which corresponds to approximately 80% to 90% battery capacity). This ensures that the battery is kept at or near a fully charged condition and eliminates the need for periodic charge cycle initiations.

### Enable Function

The LP28014 features an enable/disable function. An input “Low” signal at EN pin or if this pin is floating will enable the IC. To assure the charger will switch on, the EN turn on control level must below 0.4 volts. The charger IC will go into the shutdown mode when the voltage on the EN pin is greater than 1.4 volts. If the enable function is not needed in a specific application, it may be tied to GND or floating to keep the charge IC in a continuously on state.

### Thermal Limiting

An internal thermal feedback loop reduces the ISET programmed charge current if the die temperature attempts to rise above a preset value of approximately 125°C. This feature protects the LP28014 from excessive temperature and allows the user to push the limits of the power handling capability of a given circuit board without risk of damaging the LP28014. The charge current can be set according to typical (not Worst-case) ambient temperature with the assurance that the charger will automatically reduce the current in worst-case conditions.



### Charge Status Indicator (CHAG & PG)

After application of a 5V source, the input voltage rises above the  $U_{VLO}$  and sleep thresholds ( $V_{IN} > V_{BAT} + V_{DT}$ ), but is less than OVP ( $V_{IN} < V_{OVP}$ ), then the PG turns on and provides a low impedance path to ground.

CHRG has two different states: strong pull-down (~5mA) and high impedance. The strong pull-down state indicates that the LP28014A is in a charge cycle. When the charger is entered CV mode and Once the charge current has reduced to the battery full charge current threshold (IBF), the CHRG pin will become high impedance.

Function	CHRG
Charging	Low
Charge END	High

Function	PG
$V_{IN} < U_{VLO}$	High
$U_{VLO} < V_{IN} < OVP$	Low
$OVP < V_{IN}$	High

### Power Dissipation

The conditions that cause the LP28014 to reduce charge current through thermal feedback can be approximated by considering the power dissipated in the IC. Nearly all of this power dissipation is generated by the internal MOSFET calculated to be approximately:

$$P_D = (V_{IN} - V_{BAT}) \cdot I_{BAT}$$

where PD is the power dissipated, VIN is the input supply voltage, VBAT is the battery voltage and IBAT is the charge current. The approximate ambient temperature at which the thermal feedback begins to protect the IC is:

$$T_A = 125^{\circ}C - P_D \cdot \theta_{JA}$$



## Packaging Information

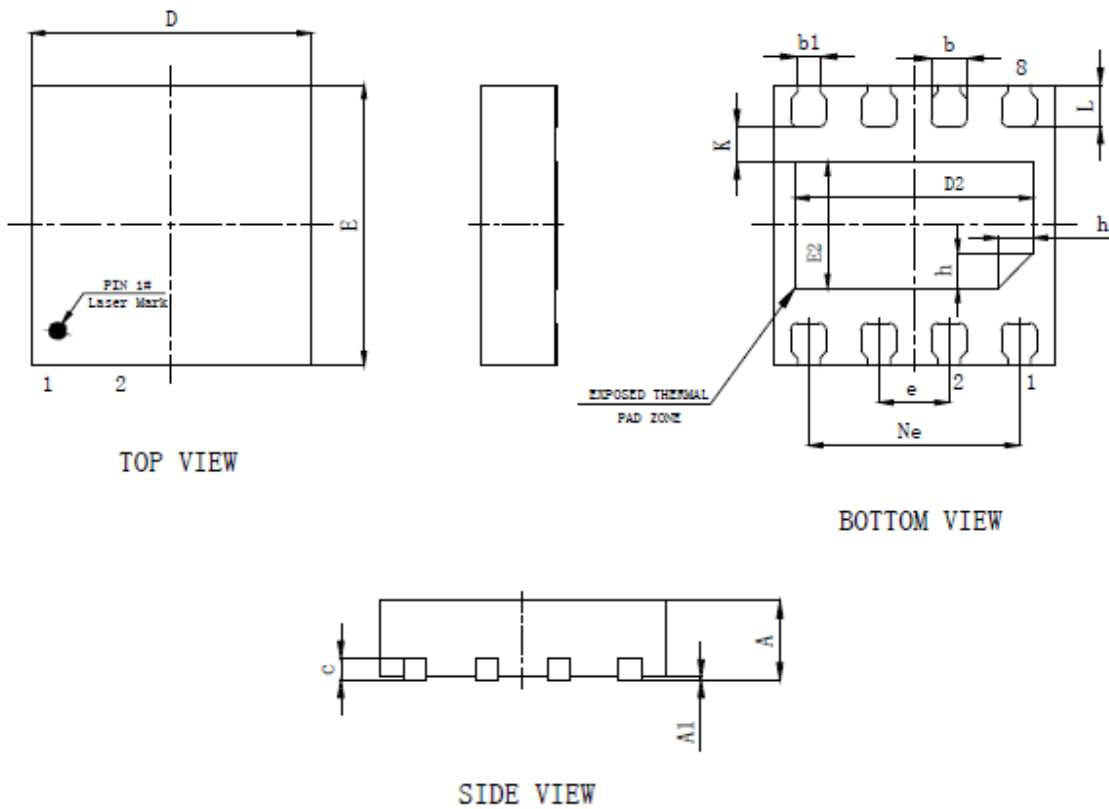

SYMBOL	MILLIMETER		
	MIN	NOM	MAX
A	0.50	0.55	0.60
A1	0	0.02	0.05
b	0.20	0.25	0.30
b1	0.11	0.16	0.21
c	0.10	0.15	0.20
D	1.90	2.00	2.10
D2	1.60	1.70	1.80
e	0.50BSC		
Ne	1.50BSC		
E	1.90	2.00	2.10
E2	0.80	0.90	1.00
L	0.25	0.30	0.35
h	0.20	0.25	0.30
K	0.20	0.25	0.30

## X-ON Electronics

Largest Supplier of Electrical and Electronic Components

*Click to view similar products for [Battery Management](#) category:*

*Click to view products by [LOWPOWER](#) manufacturer:*

Other Similar products are found below :

[MP2602DQ-LF-P](#) [MP26053DQ-LF-Z](#) [MP2611GL-P](#) [NCP347MTAHTBG](#) [LM3658SD-AEV/NOPB](#) [MP2607DL-LF-P](#) [MP26121DQ-LF-P](#)  
[MP26123DR-LF-P](#) [MP2633GR-P](#) [MP2637GR-P](#) [BQ24212EVM-678](#) [NCP1855FCCT1G](#) [MP2636GR-P](#) [FAN54063UCX](#)  
[MAX14680EWC+T](#) [MAX14634EWC+T](#) [DS2745U+T&R](#) [MAX14578EETE+T](#) [DS2781EVKIT+](#) [DS2781E+T&R](#) [MP2605DQ-LF-P](#)  
[DS2710G+T&R](#) [MAX17040G+T](#) [MAX14525ETA+T](#) [MP2615GQ-P](#) [MAX14578EEWC+T](#) [LC05132C01NMTTGTG](#) [MAX8971EWP+T](#)  
[MAX14630EZK+T](#) [MAX1873TEEE+T](#) [PSC5415A](#) [AUR9811DGD](#) [SN2040DSQR](#) [DS2715BZ+T&R](#) [MAX1508ZETA+T](#)  
[MAX14921ECS+T](#) [MAX77301EWA+T](#) [BD8668GW-E2](#) [MAX16024PTBS+T](#) [DS2715Z+T&R](#) [MAX16024LTBZ18+T](#) [DS2782E+T&R](#)  
[DS2782G+T&R](#) [MAX1908ETI+T](#) [ISL95522IRZ](#) [ISL95522HRZ](#) [ARD00558](#) [NCP4371AAEDR2G](#) [BD8665GW-E2](#) [MAX8934EETI+T](#)