



1.0A Single-chip Li-ion and Li-POL Charger with OVP Protection

General Description

The LP28021/A is a complete constant-current/ constant voltage linear charger for single cell lithium-ion batteries. Its TDFN-10 package and low external component count make the LP28021/A ideally suited for portable applications. No external sense resistor is needed, and no blocking diode is required due to the internal MOSFET architecture. Thermal feedback regulates the charge current to limit the die temperature during high power operation or high ambient temperature. The charge voltage is fixed at 4.2V, and the charge current can be rammed externally with a single resistor(R_{IBAT}). The LP28021 automatically terminates the charge cycle when the charge current drops to 1/10th the R_{IBAT} rammed value after the final float voltage is reached.

When the input supply is removed, the LP28021/A automatically enters a low current state, dropping the battery drain current to less than 1µA.

Other features include charge current monitor, under voltage lockout, automatic recharge and a status pin to indicate charge termination and the presence of an input voltage.

Order Information

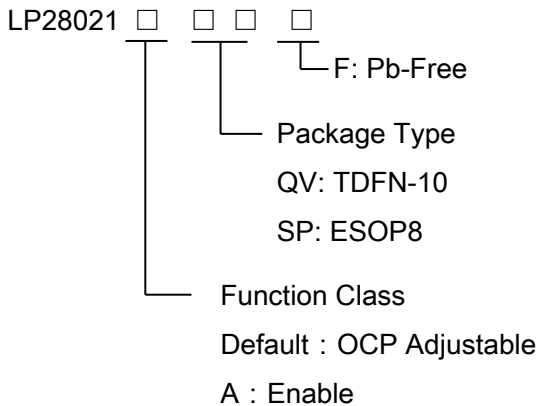

Features

- ◆ Very Low Power Dissipation
- ◆ Input Voltage: 4V~36V
- ◆ Input OVP: 6.1V
- ◆ Protection of Reverse Connection of Battery
- ◆ Programmable Charge Current Up to 1000mA
- ◆ No MOSFET, Sense Resistor or Blocking Diode Required
- ◆ Constant-Current/Constant-Voltage Operation with Thermal Regulation to Maximize Charge Rate Without Risk of Overheating
- ◆ 1µA Leakage Current in Shutdown
- ◆ Drainage Charge Current Thermal Regulation Status Outputs for LED or System Interface
- ◆ Indicates Charge and Fault Conditions
- ◆ Consumption Available in TDFN-10 Package
- ◆ RoHS Compliant and 100% Lead (Pb)-Free

Applications

- ◇ Portable Media Players/Game
- ◇ Power Bank
- ◇ PDA/MID
- ◇ Bluetooth Applications

Marking Information

Device	Marking	Package	Shipping
LP28021QVF	LPS	QV:TDFN-10	5K/REEL
LP28021SPF	LP28021 YWX	SP:ESOP8	4K/REEL
LP28021AQVF	LPS LP28021A YWX	QV:TDFN-10	5K/REEL

Marking indication:
Y:Production year W:Production week X: Series Number



Typical Application Circuit

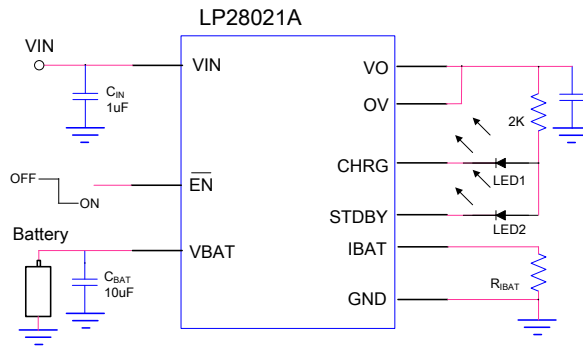
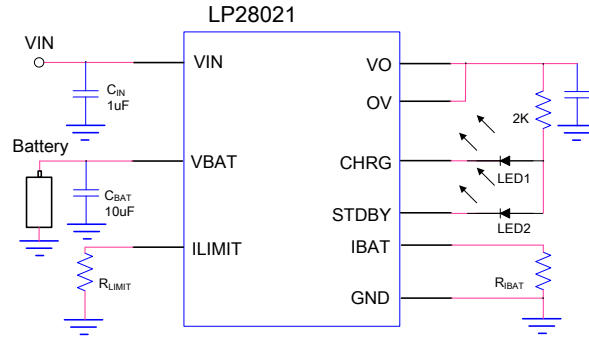

Functional Pin Description

Package Type	Pin Configurations
ESOP8 / TDFN-10 (LP28021)	
TDFN-10 (LP28021A)	



Pin Description

Pin			Name	Description
LP28021		LP28021A		
ESOP8	TDFN-10	TDFN-10		
6,9	1,7,11	1,7,11	GND	GND is the connection to system ground.
1	2		ILIMIT	Input Current limit Program Pin. The input current from VIN to OV is programmed by connecting a 1% resistor(R_{LIMIT})to ground.
		2	/EN	Chip enable pin. Active low
2	3	3	BAT	BAT is the connection to the battery. Typically a 10 μ F Tantalum capacitor is needed for stability when there is no battery attached. When a battery is attached, only a 0.1 μ F ceramic capacitor is required.
3	4	4	STDBY	Open-Drain Charge Status Output. When the battery is charging, this STDBY pin is pulled High by an internal N-channel MOSFET. When the charge cycle is completed, the pin is pulled Low.
4	5	5	CHRG	Open-Drain Charge Status Output. When the battery is charging, this CHRG pin is pulled low by an internal N-channel MOSFET. When the charge cycle is completed, the pin is pulled High.
5	6	6	IBAT	Charge Current Program, Charge Current Monitor and Shutdown Pin. The charge current is programmed by connecting a 1% resistor(R_{IBAT})to ground. When charging in constant-current mode, this pin serves to 1V. In all modes, the voltage on this pin can be used to measure the charge current using the following formula. $I_{BAT}=1000/R_{IBAT}$.
7	8	8	VO	Input of Charger. Connect a capacitor 10uF to ground.
	9	9	OV	Output of Over Voltage Protection part. Connect a capacitor 10uF to ground.
8	10	10	VIN	VIN is the input power source with Over Voltage Protection part. Connect to a wall adapter.



Function Diagram

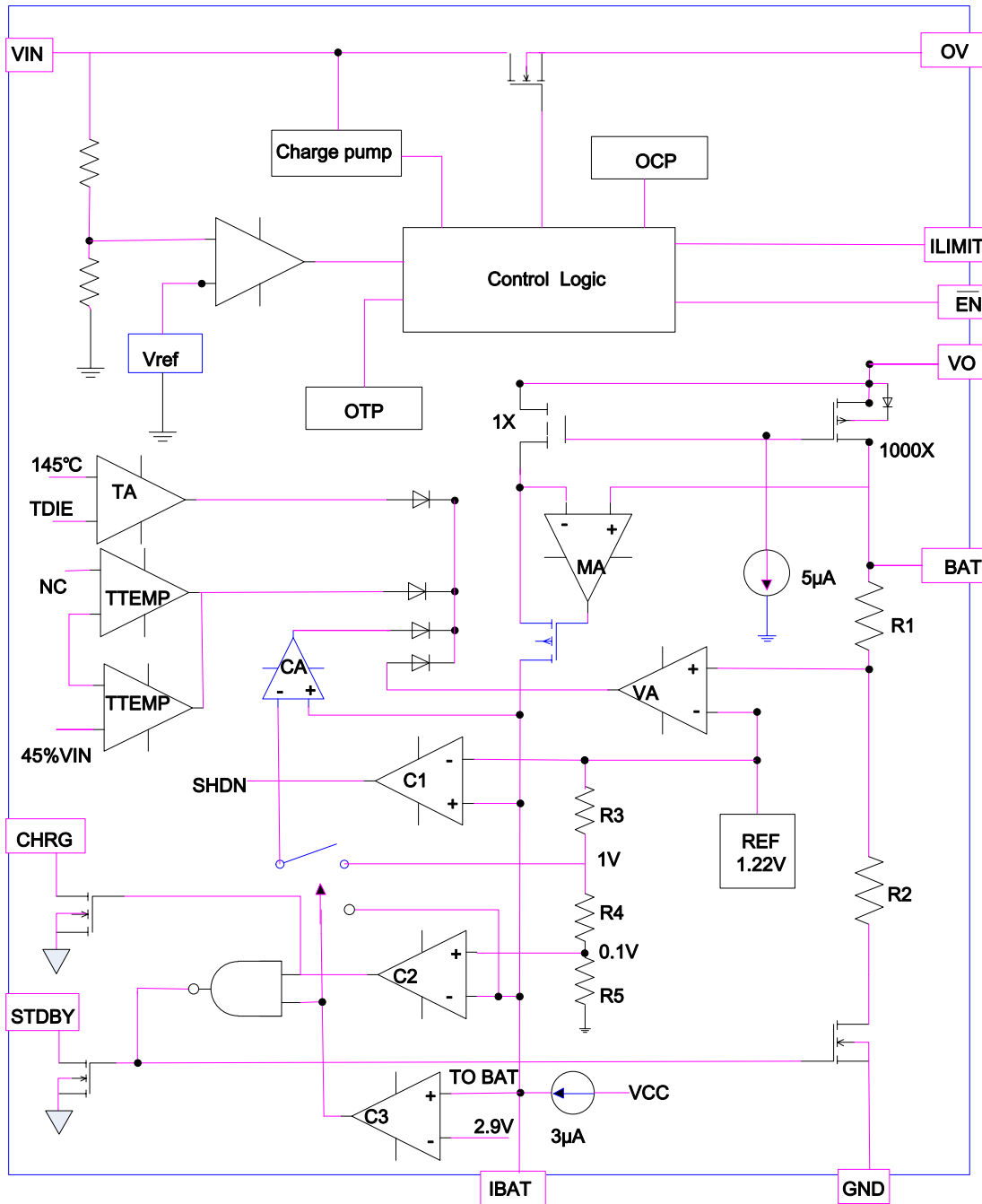



Absolute Maximum Ratings ^{Note 1}

- ◇ Input Voltage to GND(VIN) ----- -0.3V to 36V
- ◇ VO, VOV Voltage to GND(VO,OV) ----- -0.3V to 7V
- ◇ BAT to GND ----- -5V to 8V
- ◇ VO to BAT ----- 8V
- ◇ BAT Short-Circuit Duration ----- Continuous
- ◇ BAT Pin Current ----- 1000mA
- ◇ Other pin to GND ----- -0.3V to 6V
- ◇ Maximum Junction Temperature ----- 150°C
- ◇ Storage Temperature Range ----- -65°C to 165°C
- ◇ Maximum Soldering Temperature (at leads, 10 sec) ----- 260°C

Note 1. Stresses beyond those listed under “Absolute Maximum Ratings” may cause permanent damage to the device. These are stress ratings only, and functional operation of the device at these or any other conditions beyond those indicated in the operational sections of the specifications is not implied. Exposure to absolute maximum rating conditions for extended periods may affect device reliability.

Thermal Information

- ◇ Maximum Power Dissipation (P_D, T_A=25°C, TDFN-10) ----- 1.5W
- ◇ Maximum Power Dissipation (P_D, T_A=25°C, ESOP8) ----- 2W
- ◇ Thermal Resistance (J_A,TDFN-10) ----- 65°C/W
- ◇ Thermal Resistance (J_A,ESOP8) ----- 50°C/W

ESD Susceptibility

- ◇ HBM(Human Body Mode) ----- 2KV
- ◇ MM(Machine Mode) ----- 200V

Recommended Operating Conditions

- ◇ Ambient Temperature Range ----- -40°C to 85°C



Electrical Characteristics

(T_A=25°C. V_{IN}=5V, unless otherwise noted.)

Symbol	Parameter	Condition	Min	Typ	Max	Units
V _{IN}	Input Voltage		4	5	36	V
V _{OVP}	OVP threshold	V _{IN} increasing from 5~7V	5.8	6.1	6.4	V
V _{HYS-OVP}	OVP hysteresis	V _{IN} decreasing from 7~5V		150		mV
T _{OVP}	OVP active time	V _{IN} =5->10V			1	μs
T _{ON(OVP)}	OVP recovery time	V _{IN} =10->5V to output ON		9		ms
I _{LIMIT}	Input current limit set (LP28021)	R _{LIMIT} =51K		1.9		A
		R _{LIMIT} =82K		1.3		A
		R _{LIMIT} =150K		0.85		A
		R _{LIMIT} =NC	2.1	2.5		A
T _{OCP}	Over current Protection detection time			30		ms
V _{ILIMIT}	ILIMIT Voltage			0.8		V
T _{ON(OCP)}	Over current Protection recovery time			1		s
V _{EN(ON)}	Chip enable	(LP28021A)			0.4	V
V _{EN(OFF)}	Chip shutdown		1.4		5	V
I _Q	Input Supply Current	Charge Mode, R _{BAT} =10k		300		μA
		Standby Mode (Charge Terminated)		100		μA
V _{FLOAT}	Regulated Output (Float) Voltage	I _{BAT} =40mA	4.158	4.2	4.242	V
I _{BAT}	BAT Pin Current	R _{BAT} =1k, Current Mode		1000		mA
		R _{BAT} =2k, Current Mode		500		mA
		Standby Mode, V _{BAT} =4.2V		-2.5	-6	μA
		Shutdown Mode (R _{BAT} NC)		±1	±2	μA
		Reverse Current, V _{BAT} =-4.2V		-1		mA
I _{TRIKL}	Trickle Charge Current	V _{BAT} <2.8V		30		mA
V _{TRIKL}	Trickle Charge Threshold Voltage	R _{BAT} =10k, V _{BAT} Rising	2.8	2.9	3.0	V
V _{TRHYS}	Trickle Charge Hysteresis Voltage	R _{BAT} =10k		120		mV
V _{UV}	V _{IN} Under voltage Lockout Threshold	V _{VO} from Low to High		3.8		V
V _{UVHYS}	V _{IN} Under voltage Lockout Hysteresis		150	200	300	mV
V _{ASD}	V _{VO} -V _{BAT} Lockout Threshold Voltage	V _{VO} from Low to High		200		mV
		V _{VO} from High to Low		100		mV
I _{TERM}	C/10 Termination Current Threshold	R _{BAT} = 10k		10		%I _{BAT}
		R _{BAT} = 2k		10		%I _{BAT}
V _{IBAT}	IBAT Pin Voltage	R _{BAT} =10K, Current Mode		1		V
I _(CHRG/STDBY)	CHRG/STDBY Pin Weak Pull-Down Current	V _(CHRG/STDBY) = 5V			5	μA
V _(CHRG/STDBY)	CHRG/STDBY Pin Output Low Voltage	I _(CHRG/STDBY) =5mA		0.35	0.6	V
ΔV _{RECHRG}	Recharge Battery Threshold Voltage	V _{FLOAT} -V _{RECHRG}	100	150	200	mV
T _{LIM}	Junction Temperature in Constant Temperature Mode			150		°C
ΔT _{LIM}	OTP hysteresis			30		°C
R _{ON}	Power FET "ON" Resistance (Between VO and BAT)			300		mΩ
t _{SS}	Soft-Start Time	I _{BAT} =0 to I _{BAT} =850V/R _{BAT}		9		ms
I _{IBAT}	IBAT Pin Pull-Up Current			150		μA



Application Information

The LP28021 is a single cell lithium-ion battery charger using a constant-current/constant-voltage algorithm. It can deliver up to 1000mA of charge current (using a good thermal PCB layout) with a final float voltage accuracy of $\pm 1\%$. The LP28021 includes an internal P-channel power MOSFET and thermal regulation circuitry. No blocking diode or external current sense resistor is required; thus, the basic charger circuit requires only two external components. Furthermore, the LP28021 is capable of operating from a USB power source.

Normal Charge Cycle

A charge cycle begins when the voltage at the VO pin rises above the UVLO threshold level and a 1% IBAT ram resistor is connected from the IBAT pin to ground or when a battery is connected to the charger output. If the BAT pin is less than 2.8V, the charger enters trickle charge mode. In this mode, the LP28021 supplies 30mA charge current to bring the battery voltage up to a safe level for full current charging.

When the BAT pin voltage rises above 2.9V, the charger enters constant-current mode, where the R_{IBAT} rammed charge current is supplied to the battery. When the BAT pin approaches the final float voltage, the LP28021 enters constant-voltage mode and the charge current begins to decrease. The charge cycle ends when the charge current drops to 1/10 of the R_{IBAT} rammed value.

Charge Termination

A charge cycle is terminated when the charge current falls to 1/10th the R_{IBAT} rammed value after the final float voltage is reached. This condition is detected by using an internal, filtered comparator to monitor the IBAT pin. When the IBAT pin voltage falls below 100mV for longer than t_{TERM} (typically 1ms), charging is terminated. The charge current is latched off and the LP28021 enters standby mode, where the input supply current drops to 200 μ A. (Note: C/10 termination is disabled in trickle charging and thermal limiting modes).

When charging, transient loads on the BAT pin can cause the IBAT pin to fall below 200mV for short periods of time before the DC charge current has dropped to 1/10th the I_{IBAT} rammed value. The 1ms filter time (t_{TERM}) on the termination comparator ensures that transient loads of this nature do not result in premature charge cycle termination. Once the average charge current drops below 1/10th the IBAT rammed value, the LP28021 terminates the charge cycle and ceases to provide any current through the BAT pin. In this state, all loads on the BAT pin must be supplied by the battery.

The LP28021 constantly monitors the BAT pin voltage in standby mode. If this voltage drops below the 4.05V recharge threshold (V_{RECHRG}), another charge cycle begins and current is once again supplied to the battery. To manually restart a charge cycle when in standby mode, the input voltage must be removed and reapplied.



IBAT ramming Charge Current

The charge current is I_{IBAT} rammed using a single resistor from the IBAT pin to ground. The battery charge current is 1000 times the current out of the I_{IBAT} pin. The I_{IBAT} ram resistor and the charge current are calculated using the following equations:

$$R_{IBAT}=1000V/I_{IBAT} \quad I_{BAT}= 1000V/R_{IBAT}$$

The charge current out of the BAT pin can be determined at any time by monitoring the IBAT pin voltage using the following equation:

$$I_{BAT}=V_{IBAT} \times 1000/R_{IBAT}$$

Note: V_{IBAT} is 1Volts.

Thermal Limiting

An internal thermal feedback loop reduces the IBAT rammed charge current if the die temperature attempts to rise above a preset value of approximately 150°C. This feature protects the LP28021 from excessive temperature and allows the user to push the limits of the power handling capability of a given circuit board without risk of damaging the LP28021. The charge current can be set according to typical (not worst-case) ambient temperature with the assurance that the charger will automatically reduce the current in worst-case conditions. TDFN power considerations are discussed further in the Applications Information section.

Charge Status Indicator

The charge status output has two different states: strong pull-down (~5mA) and high impedance. The strong pull-down state indicates that the LP28021 is in a charge cycle. Once the charge cycle has terminated, the pin state is determined by under voltage lockout conditions. High impedance indicates that the LP28021 is in under voltage lockout mode: either VO is less than 100mV above the BAT pin voltage or insufficient voltage is applied to the VO pin.

A microprocessor can be used to distinguish between these two states—this method is discussed in the Applications Information section. When VIN rise above 6.1V(typ.), the CHRG and STDBY LEDs would be turned off.

A microprocessor can be used to distinguish between these two states—this method is discussed in the Applications Information section.

Function	CHRG	STDBY
Charging	low	high
Charge Complete	high	low



Packaging Information

TDFN-10

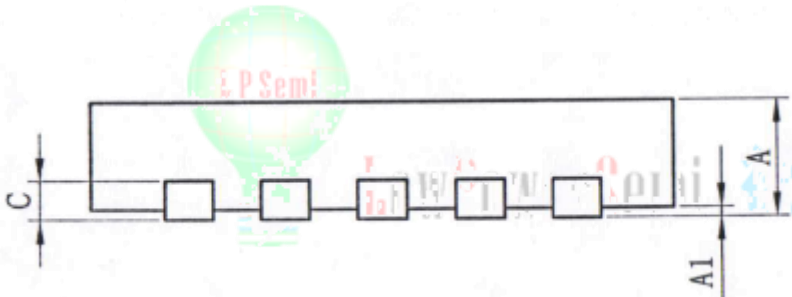
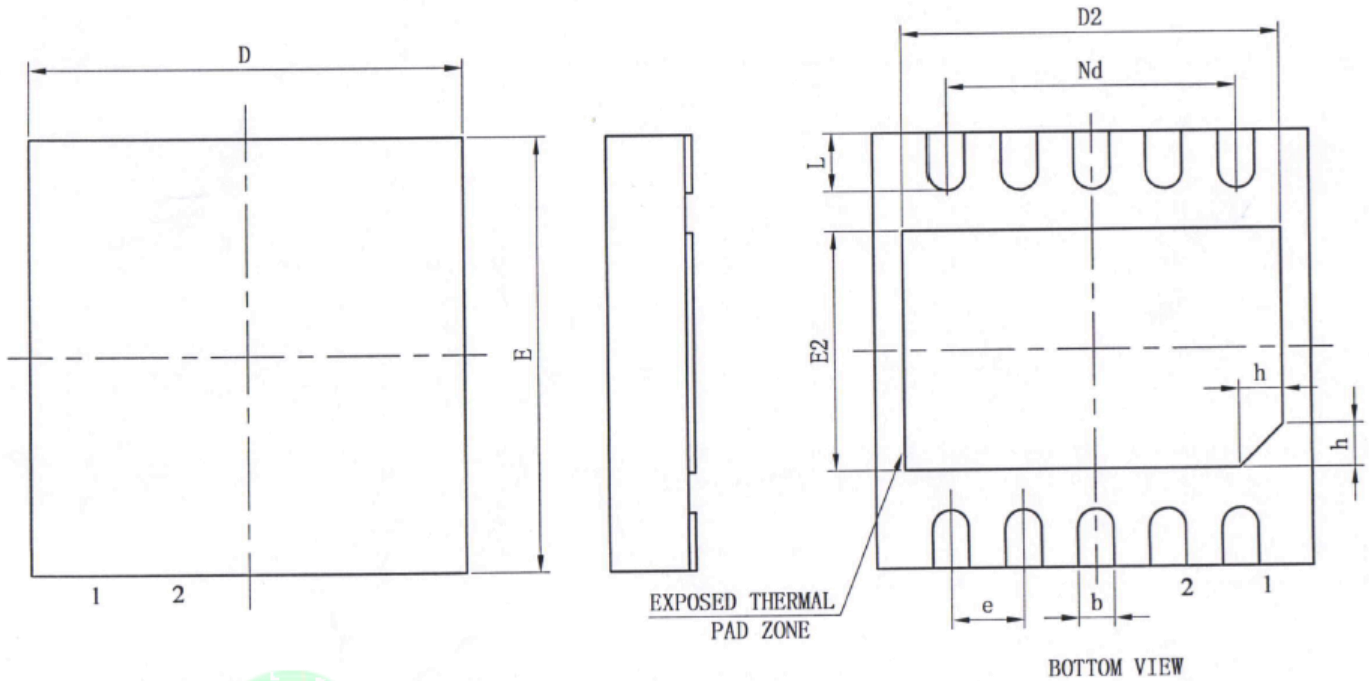

SYMBOL	MILLIMETER		
	MIN	NOM	MAX
A	0.70	0.75	0.80
A1	—	0.02	0.05
b	0.18	0.25	0.30
c	0.18	0.20	0.25
D	2.90	3.00	3.10
D2	2.40	2.50	2.60
e	0.50BSC		
Nd	2.00BSC		
E	2.90	3.00	3.10
E2	1.45	1.55	1.65
L	0.30	0.40	0.50
h	0.20	0.25	0.30



ESOP8

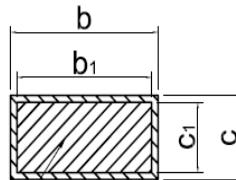
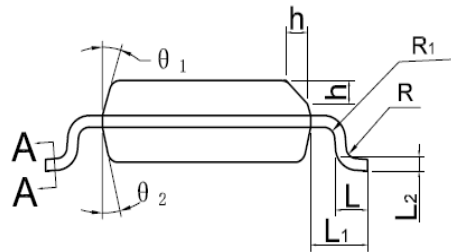
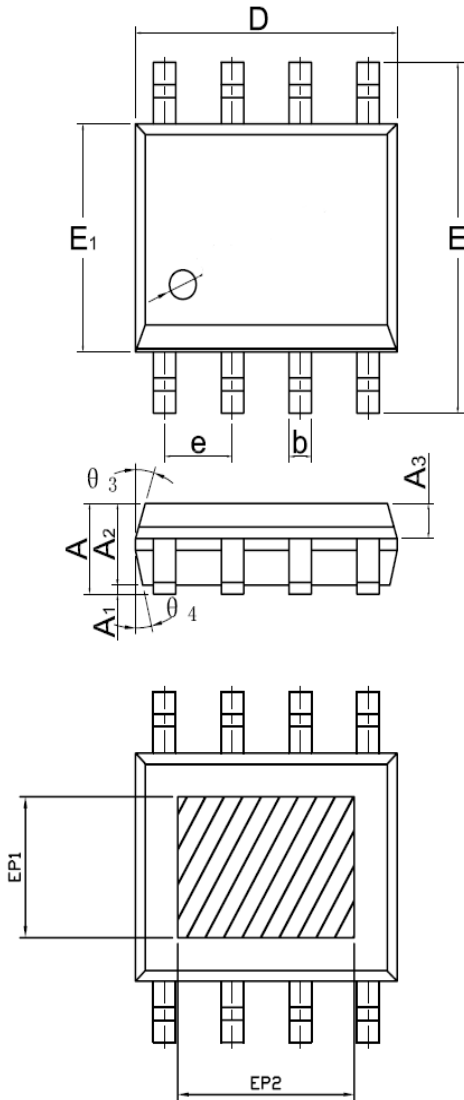

BASE METAL

SECTION A-A
6:1

DIMENSIONS IN MILLIMETERS

SYMBOL	MIN	NOM	MAX
A	1,35	1,55	1,75
A ₁	0,00	—	0,10
A ₂	1,25	1,40	1,65
A ₃	0,50	0,60	0,70
b	0,39	—	0,49
b ₁	0,28	—	0,48
c	0,10	—	0,25
c ₁	0,10	—	0,23
D	4,80	4,90	5,00
E	5,80	6,00	6,20
E ₁	3,80	3,90	4,00
e	1,27BSC		
L	0,45	—	1,00
L ₁	1,04REF		
L ₂	0,25BSC		
R	0,07	—	—
R ₁	0,07	—	—
h	0,3	0,4	0,5
	0°	—	8°
θ_1	11°	17°	19°
θ_2	11°	13°	15°
θ_3	15°	17°	19°
θ_4	11°	13°	15°
EP1	2,40	—	—
EP2	3,30	—	—

X-ON Electronics

Largest Supplier of Electrical and Electronic Components

Click to view similar products for [Battery Management](#) category:

Click to view products by [LOWPOWER](#) manufacturer:

Other Similar products are found below :

[MP2602DQ-LF-P](#) [MP26053DQ-LF-Z](#) [MP2611GL-P](#) [NCP347MTAHTBG](#) [LM3658SD-AEV/NOPB](#) [MP2607DL-LF-P](#) [MP26121DQ-LF-P](#)
[MP26123DR-LF-P](#) [MP2633GR-P](#) [MP2637GR-P](#) [BQ24212EVM-678](#) [NCP1855FCCT1G](#) [MP2636GR-P](#) [FAN54063UCX](#)
[MAX14680EWC+T](#) [MAX14634EWC+T](#) [DS2745U+T&R](#) [MAX14578EETE+T](#) [DS2781EVKIT+](#) [DS2781E+T&R](#) [MP2605DQ-LF-P](#)
[DS2710G+T&R](#) [MAX17040G+T](#) [MAX14525ETA+T](#) [MP2615GQ-P](#) [MAX14578EEWC+T](#) [LC05132C01NMTTGTG](#) [MAX8971EWP+T](#)
[MAX14630EZK+T](#) [MAX1873TEEE+T](#) [PSC5415A](#) [AUR9811DGD](#) [SN2040DSQR](#) [DS2715BZ+T&R](#) [MAX1508ZETA+T](#)
[MAX14921ECS+T](#) [MAX77301EWA+T](#) [BD8668GW-E2](#) [MAX16024PTBS+T](#) [DS2715Z+T&R](#) [MAX16024LTBZ18+T](#) [DS2782E+T&R](#)
[DS2782G+T&R](#) [MAX1908ETI+T](#) [ISL95522IRZ](#) [ISL95522HRZ](#) [ARD00558](#) [NCP4371AAEDR2G](#) [BD8665GW-E2](#) [MAX8934EETI+T](#)