



High Performance, Constant Current Switching Regulator For White LED

General Description

The LP3307 is a high frequency, asynchronous boost converter for constant current white LED driver applications. The internal MOSFET can support up to 8 White LEDs for backlighting and OLED power application, and the internal soft start function can reduce the inrush current. The LED current is initially set with the external sense resistor. To improve efficiency, the feedback voltage is set to 250mV, which reduces the power dissipation in the current setting resistor.

The LP3307 implements a constant frequency 1MHz PWM control scheme. Optimized operation frequency can meet the requirement of small LC filters value. Highly integration and internal compensation network minimizes as 5 external component counts to provide the best solution for PCB space saving and total BOM cost. SOT23-6 packages.

Features

- ◆ High Efficiency: 93%
- ◆ 1.1MHz Fixed-Frequency PWM Operation
- ◆ Maximum Output Voltage up to 29V
- ◆ Operating Range : 2.2V to 6V
- ◆ Shutdown Supply Current:<1uA
- ◆ Available in SOT23-6 Package
- ◆ Built-in Over Voltage Protection
- ◆ Minimize the External Component
- ◆ RoHS Compliant and 100% Lead Pb-Free

Applications

- ◇ WLED Backlight driver
- ◇ OLED Backlight driver
- ◇ PDA
- ◇ DSC
- ◇ Camera Flash WLED driver

Order Information

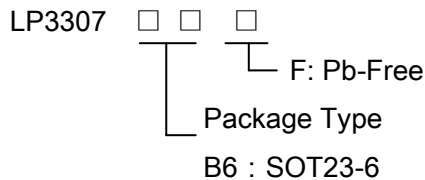

Marking Information

Device	Marking	Package	Shipping
LP3307B6F		SOT23-6	3K/REEL

Typical Application Circuit

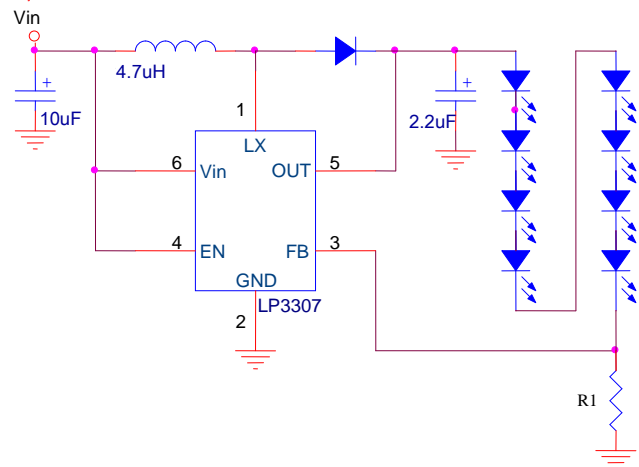



Application Circuits

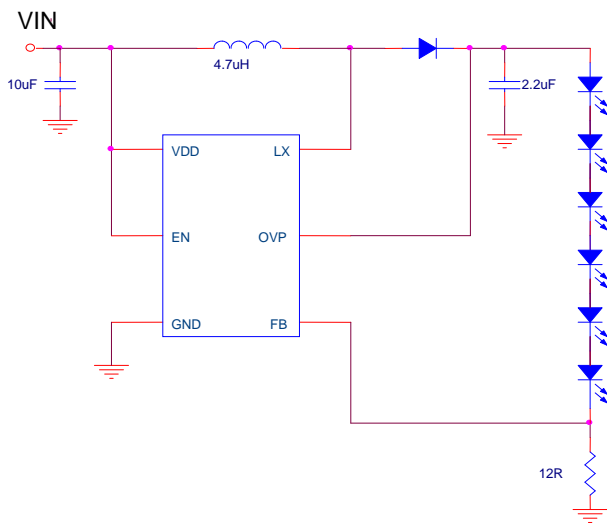

LP3307 for 6pcs Application Circuit

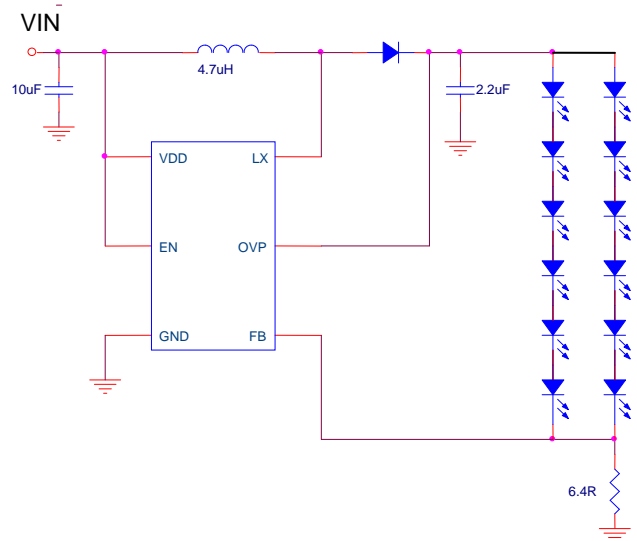

LP3307 for 6pcs×2 Application Circuit

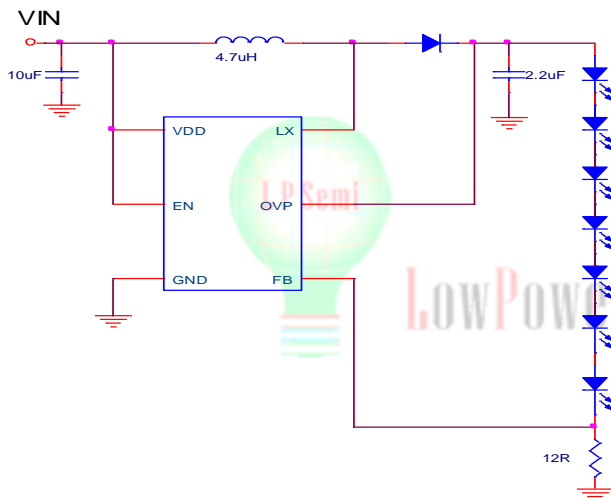

LP3307 for 7pcs Application Circuit

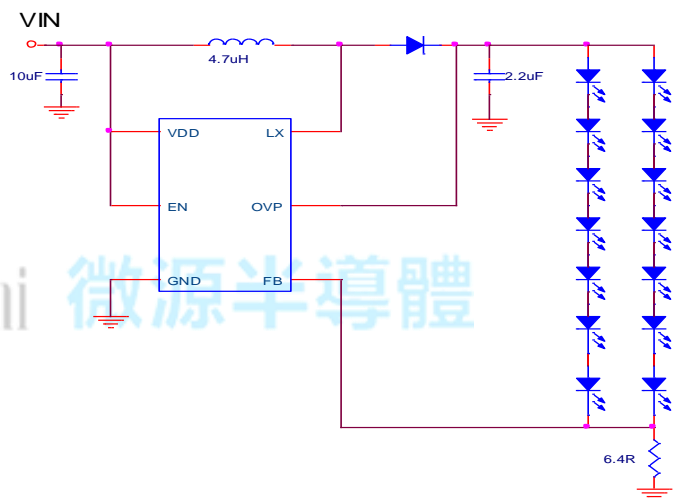

LP3307 for 7pcs×2 Application Circuit

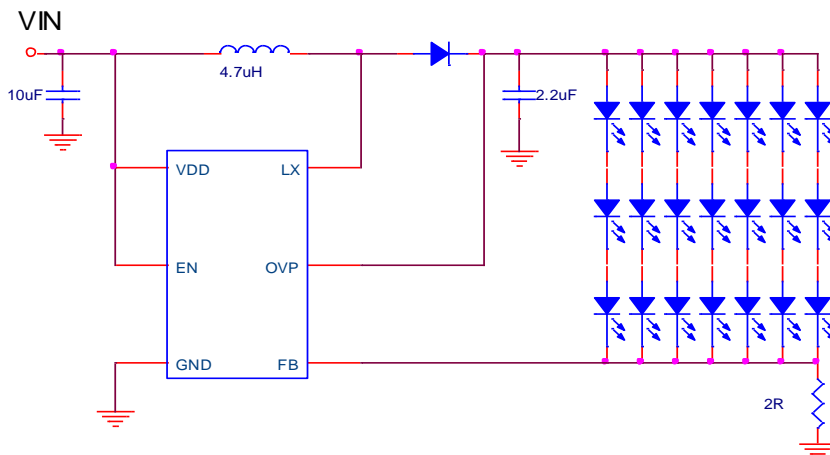

LP3307 for 3pcs×7 Application Circuit

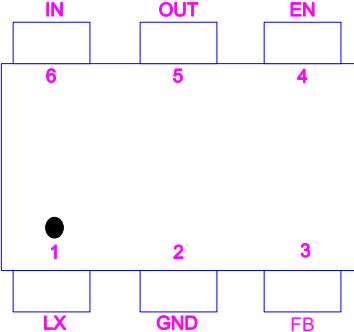

Functional Pin Description

Package Type	Pin Configurations
SOT23-6	

Pin Description

Pin	Name	Description
1	LX	Switch Pin. Connect this Pin to inductor and catch diode. Minimize the track area to reduce EMI.
2	GND	Ground Pin
3	FB	Feedback Reference Voltage Pin. Series connect a resistor between WLED and ground as a current sense. Sense the current feedback voltage to set the current rating.
4	EN	Chip Enable (Active High). Voltage sensing input to trigger the function of over voltage protection. Note that this pin is high impedance. There should be a pull low 100kΩ resistor connected to GND when the control signal is floating.
5	OUT	OVP Pin. Overvoltage Sense.
6	VIN	Supply Input Voltage Pin. Bypass 10uF capacitor to GND to reduce the input noise.



Electrical Characteristics

Parameter	Symbol	Test Condition	Min.	Typ.	Max.	Units
System Supply Input						
Operation voltage Range	VDD		2.2		6	V
Under Voltage Lock Out	VDD		1.8	2	2.2	V
Shut Down Current	IDD	VEN < 0.4V			1	uA
Line Regulation		VIN : 3.0~4.3V		3		%
Oscillator						
Operation Frequency	FOSC			1.1		MHz
Maximum Duty Cycle			89	92	96	%
Dimming Frequency			100		1M	Hz
Feedback Voltage	LP3307		235	250	270	mV
MOSFET						
On Resistance of MOSFET	RDS(ON)			0.27		Ω
Protection						
OVP Threshold	VOVP			29		V
OVP Sink Current				5		μA
OCP			1100			mA
Shut Down Voltage	VEN				0.4	V
Enable Voltage	VEN		1.4			V



Typical Operating Characteristics

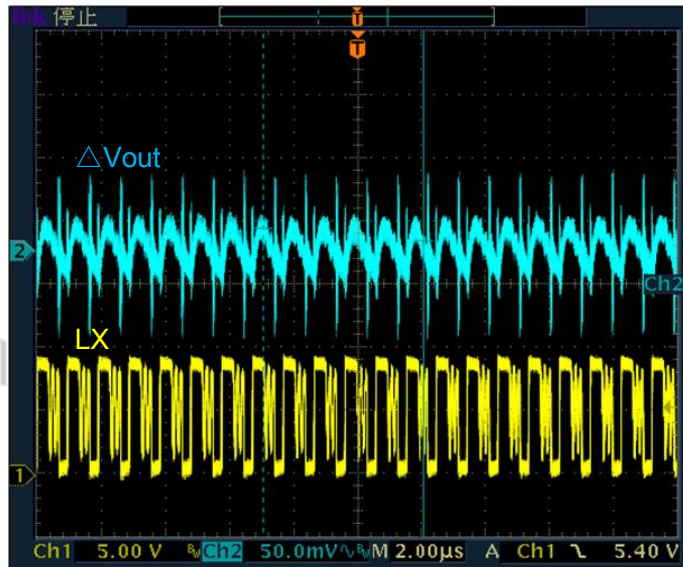
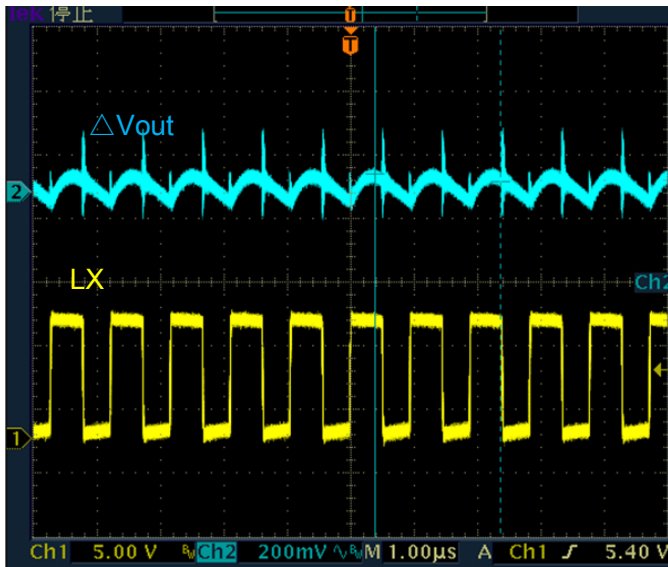
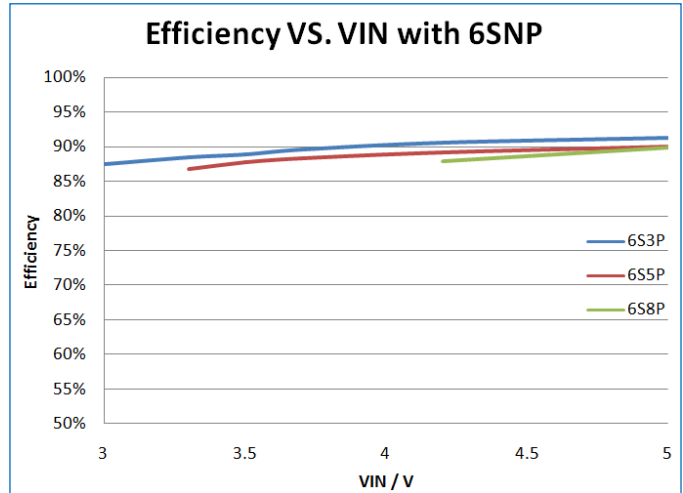
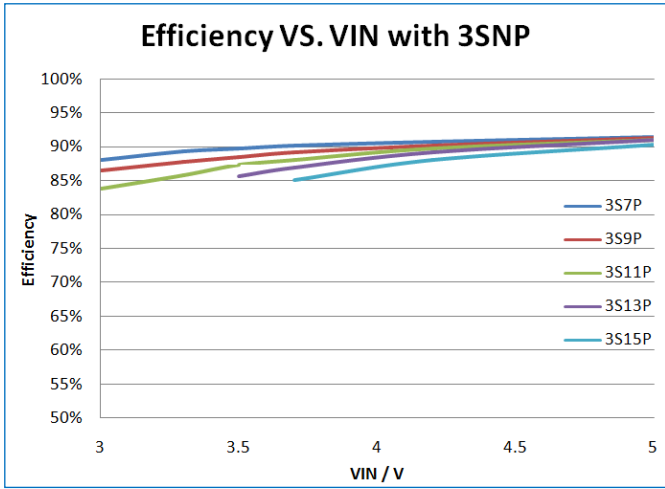



Applications Information

LED Current Control

The LP3307 regulates the LED current by setting the current sense resistor (R1) connecting to feedback and ground. The internal feedback reference voltage is 0.25V. The LED current can be set from following equation easily.

$$I_{LED}=250mV/R1$$

In order to have an accurate LED current, precision resistors are preferred (1% is recommended). The table for R2 selection is shown below.

R1 Resistor Value selection

I _{LED} (mA)	R1(Ω)
5	50
10	25
12	21
20	12.5

Inductor Selection

The recommended value of inductor for 2 to 8WLEDs applications are 4.7 to 15μH. Small size and better efficiency are the major concerns for portable device, such as LP3307 used for mobile phone. The inductor should have low core loss at 1.1MHz and low DCR for better efficiency. To avoid inductor saturation current rating should be considered.

Dimming control

a. Using a PWM Signal to EN Pin

To control the brightness of LED, the LP3307 can perform the dimming control by applying a PWM signal to EN pin. The internal soft-start and wide range dimming frequency from 100Hz to 1MHz can insignificantly reduce audio noise when dimming. The average LED current is proportional to the PWM signal duty cycle. The magnitude of the PWM signal should be higher than the maximum enable voltage of EN pin, in order to let the dimming control perform correctly.

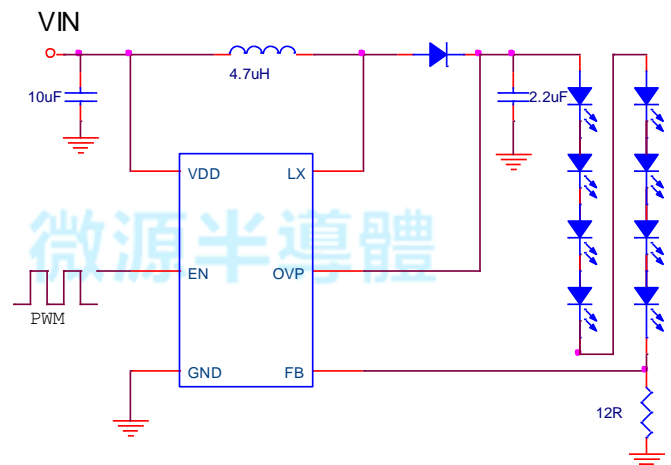

b. Using a DC Voltage

Using a variable DC voltage to adjust the brightness is a popular method in some applications. The dimming control using a DC voltage circuit is shown below . According to the Superposition Theorem, as the DC voltage increases, the voltage contributed to VFB increases and the voltage drop on R1 decreases, i.e. the LED current decreases. For example, if the VDC range is from 0V to 2.8V, the selection of resistors below sets dimming control of LED current from 20mA to 5.5mA.

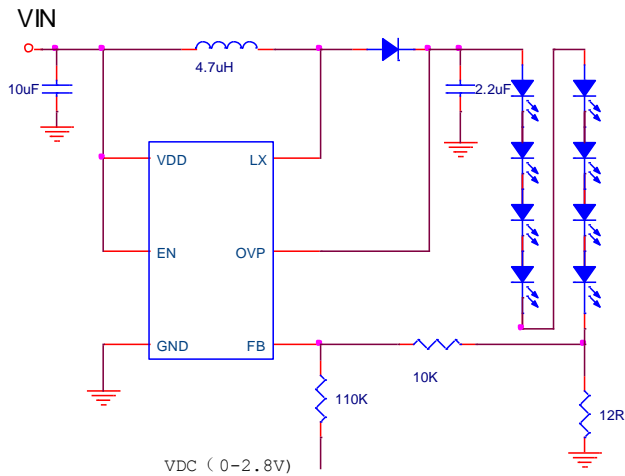

c. Using a Filtered PWM signal

Another common application is using a filtered PWM signal as an adjustable DC voltage for LED dimming control. A filtered PWM signal acts as the DC voltage to regulate the output current. The recommended application circuit is shown in the Figure . In this circuit, the output ripple depends on the frequency of PWM signal. For smaller output voltage ripple (<100mV), the recommended frequency of 2.8V PWM signal should be above 2kHz. To fix the frequency of PWM signal and change the duty cycle of PWM signal can get different output current. According to the application circuit of Figure , output current is from 20.5mA to 5.5mA by adjusting the PWM duty cycle from 10% to 90%.

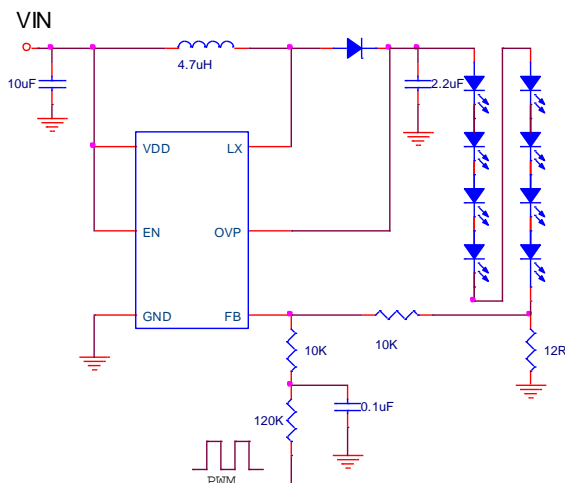

Thermal Considerations

For continuous operation, do not exceed absolute maximum operation junction temperature. The maximum power dissipation depends on the thermal resistance of IC package, PCB layout, the rate of surroundings airflow and temperature difference between junction to ambient.

The maximum power dissipation can be calculated by following formula :

$$PD(MAX) = (T_J(MAX) - T_A) / q_{JA}$$

Where $T_J(MAX)$ is the maximum operation junction temperature, T_A is the ambient temperature and the q_{JA} is the junction to ambient thermal resistance. For the recommended operating conditions specification of LP3307, the maximum junction temperature of the die is 125 °C. The junction to ambient thermal resistance q_{JA} is layout dependent. The junction to ambient thermal resistance for TSOT-23-6 package is 250°C/W on the standard JEDEC51-3 single layer thermal test board. The maximum power dissipation at $T_A = 25°C$ can be calculated by following formula :

$$PD(MAX) = (125°C - 25°C) / (250°C/W) = 0.4W$$

The maximum power dissipation depends on operating ambient temperature for fixed $T_J(MAX)$ and thermal resistance q_{JA} .



Packaging Information

SOT23-6

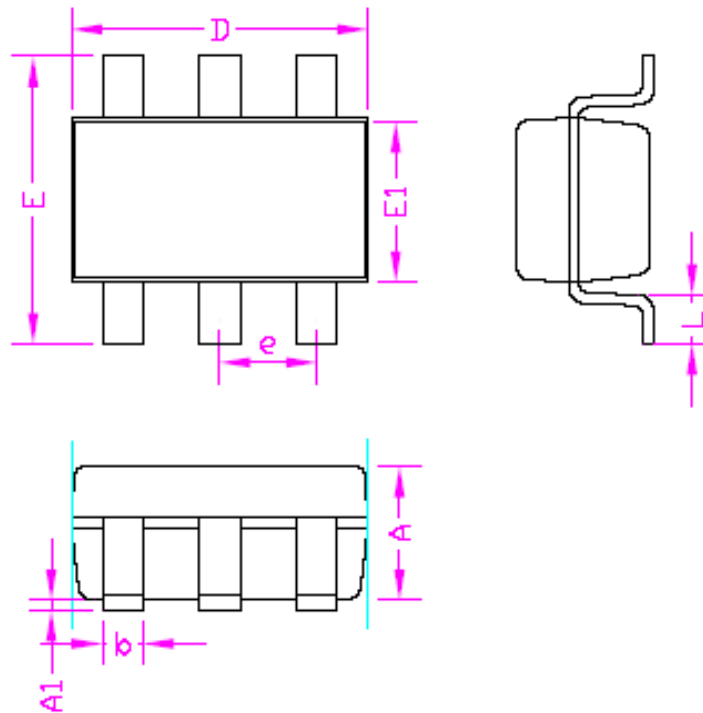

SYMBOLS	MILLIMETERS		INCHES	
	MIN.	MAX.	MIN.	MAX.
A	-	1.45	-	0.057
A1	0.00	0.15	0.000	0.006
b	0.30	0.50	0.012	0.020
D	2.90		0.114	
E1	1.60		0.063	
e	0.95		0.037	
E	2.60	3.00	0.102	0.118
L	0.3	0.60	0.012	0.024

X-ON Electronics

Largest Supplier of Electrical and Electronic Components

Click to view similar products for [LED Display Drivers](#) category:

Click to view products by [LOWPOWER](#) manufacturer:

Other Similar products are found below :

[MAP9000QNRH](#) [AP5726WUG-7](#) [AL8806QMP-13](#) [AP5726FDCG-7](#) [AS3693B-ZTQT](#) [AP5725WUG-7](#) [MAX139EQH+D](#) [STP16DP05PTR](#)
[STP16CPP05PTR](#) [STP16CPP05XTTR](#) [LV5236VZ-TLM-H](#) [BP9911CC](#) [ZXLD1366QEN8TC](#) [MT7725D](#) [TX6143](#) [SY6813PEC](#) [SD1002L4](#)
[AW3643CSR](#) [MP3370GN-Z](#) [LA2284L-G09-T](#) [SEDA](#) [SCT2027CSSG](#) [LYT3315D](#) [LYT3324D](#) [LYT4211E2](#) [LYT4214E2](#) [LYT4215E2](#)
[LYT4217E2](#) [LYT4218E2](#) [LYT4222E](#) [LYT4317E2](#) [LYT4321E](#) [LYT4323E](#) [LYT4324E3](#) [LYT4326E3](#) [TPS92020DR](#) [TPS92691PWPR](#)
[BCR420U](#) [HV9801ALG-G](#) [IS31FL3199-QFLS2-TR](#) [IS31FL3731-QFLS2-TR](#) [CAT4238TD](#) [SCT2001ASIG](#) [SCT2024CSTG](#) [SCT2167CSOG](#)
[SCT2167CSSG](#) [STP16CPPS05XTTR](#) [TLE4241GMFUMA1](#) [ICM7212MIQH+D](#) [ICM7212AIQH+D](#)