



500mA, Ultra-low noise, Small Package Ultra-Fast CMOS LDO Regulator

General Description

The LP3980 is designed for portable RF and wireless applications demanding performance and space requirements. The LP3980 performance is optimized for battery-powered systems to deliver ultra low noise and low quiescent current. Regulator ground current increases only slightly in dropout, further prolonging the battery life. The LP3980 also works with low-ESR ceramic capacitors, reducing the amount of board space necessary for power applications, critical in hand-held wireless devices. The LP3980 consumes less than 0.01µA in shutdown mode and has fast turn-on time less than 50µs. The other features include ultra low dropout voltage, high output accuracy, current limiting protection, and high ripple rejection ratio.

Applications

- ✧ Portable Media Players/MP3 players
- ✧ Cellular and Smart mobile phone
- ✧ LCD
- ✧ DSC Sensor
- ✧ Wireless Card

Features

- ◆ 1.6V- 5.5V Input Voltage Range
- ◆ Low Dropout : 240mV @ 300mA
- ◆ 500mA Output Current
- ◆ High PSSR: -76dB at 1KHz
- ◆ 0.01uA Standby Current When Shutdown
- ◆ Ultra-Fast Response in Line/Load transient
- ◆ Current Limiting
- ◆ Thermal Shutdown Protection
- ◆ Available in SOT23-5/SOT23/TDFN-4 Package

Order Information

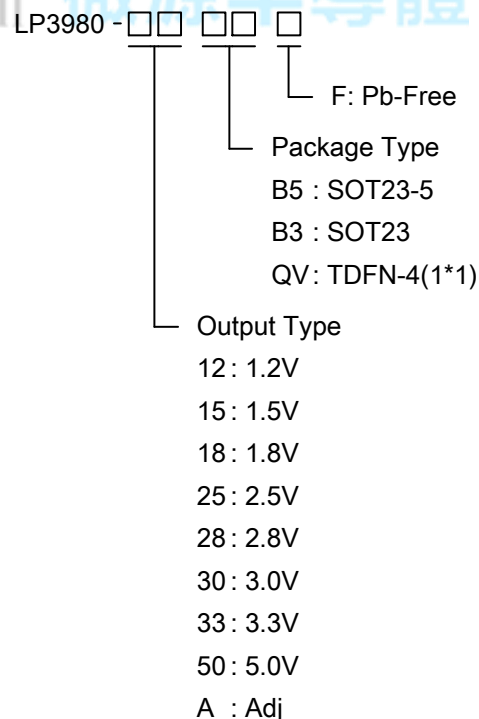



Marking Information

Device	Marking	Package	Shipping	Device	Marking	Package	Shipping
LP3980-12B5F	LP3980 12 YWX	SOT23-5	3K/REEL	LP3980-18B3F	LP3980 18 YWX	SOT23	3K/REEL
LP3980-15B5F	LP3980 15 YWX	SOT23-5	3K/REEL	LP3980-25B3F	LP3980 25 YWX	SOT23	3K/REEL
LP3980-18B5F	LP3980 18 YWX	SOT23-5	3K/REEL	LP3980-28B3F	LP3980 28 YWX	SOT23	3K/REEL
LP3980-25B5F	LP3980 25 YWX	SOT23-5	3K/REEL	LP3980-30B3F	LP3980 30 YWX	SOT23	3K/REEL
LP3980-28B5F	LP3980 28 YWX	SOT23-5	3K/REEL	LP3980-33B3F	LP3980 33 YWX	SOT23	3K/REEL
LP3980-30B5F	LP3980 30 YWX	SOT23-5	3K/REEL	LP3980-50B3F	LP3980 50 YWX	SOT23	3K/REEL
LP3980-33B5F	LP3980 33 YWX	SOT23-5	3K/REEL	LP3980-12QVF	BYW	TDFN-4	12K/REEL
LP3980-50B5F	LP3980 50 YWX	SOT23-5	3K/REEL	LP3980-18QVF	CYW	TDFN-4	12K/REEL
LP3980-AB5F	LP3980 A YWX	SOT23-5	3K/REEL	LP3980-28QVF	HYW	TDFN-4	12K/REEL
LP3980-12B3F	LP3980 12 YWX	SOT23	3K/REEL	LP3980-30QVF	GYW	TDFN-4	12K/REEL
LP3980-15B3F	LP3980 15 YWX	SOT23	3K/REEL	LP3980-33QVF	EYW	TDFN-4	12K/REEL

Marking indication:
Y: Production year W: Production week X: Series Number

Typical Application Circuit

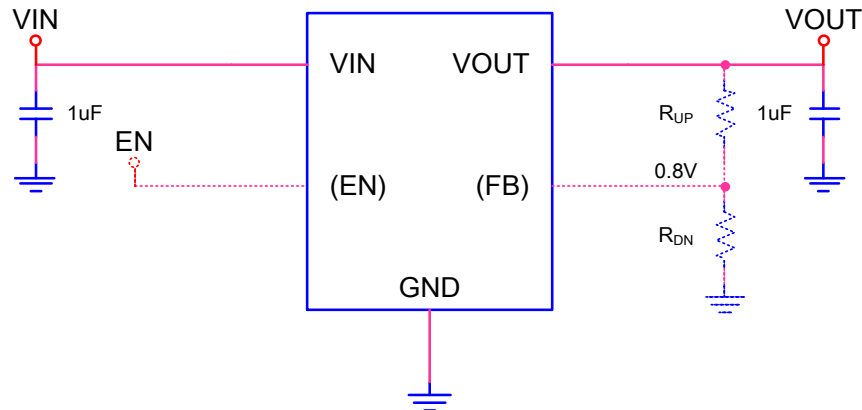

Note1: Only the SOT23-5 package has an EN pin.

Note2: Only LP3980AB5F has an FB pin. The reference voltage is 0.8V. $V_{OUT} = 0.8V \times \left(1 + \frac{R_{UP}}{R_{DN}}\right)$



Functional Pin Description

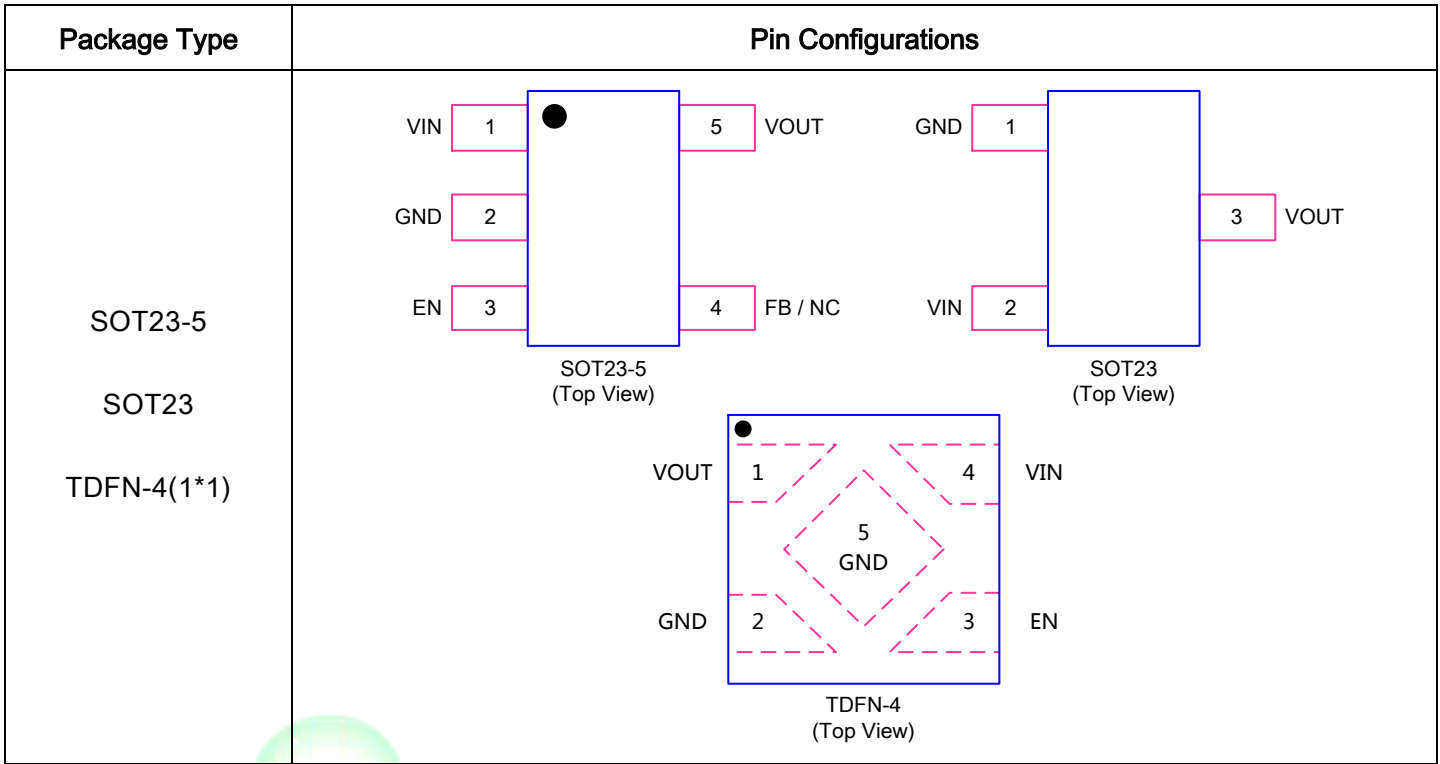

Pin Description

Pin No.			Name	Description
SOT23-5	SOT23	TDFN-4		
1	2	4	VIN	Power Input voltage.
2	1	2	GND	Ground.
3	-	3	EN	Enable pin.
4	-	-	NC	No connect.
			FB (LP3980A)	Feedback pin. The reference voltage is 0.8V.
5	3	1	VOUT	Output voltage.



Absolute Maximum Ratings ^{Note 1}

- ◇ Input to GND ----- -0.3V to 6V
- ◇ EN to GND ----- -0.3V to 6V
- ◇ Output Voltage to GND ----- -0.3V to (VIN+0.3V)
- ◇ Maximum Junction Temperature ----- 150°C
- ◇ Operating Ambient Temperature Range (T_A) ----- -40°C to 85°C
- ◇ Maximum Soldering Temperature (At leads, 10 sec) ----- 260°C

Note 1. Stresses beyond those listed under “Absolute Maximum Ratings” may cause permanent damage to the device. These are stress ratings only, and functional operation of the device at these or any other conditions beyond those indicated in the operational sections of the specifications is not implied. Exposure to absolute maximum rating conditions for extended periods may affect device reliability.

Thermal Information

- ◇ Maximum Power Dissipation (SOT23-5, P_D, T_A=25°C) ----- 400mW
- ◇ Thermal Resistance (SOT23-5, θ_{JA}) ----- 250°C/W
- ◇ Maximum Power Dissipation (SOT23, P_D, T_A=25°C) ----- 350mW
- ◇ Thermal Resistance (SOT23, θ_{JA}) ----- 350°C/W
- ◇ Maximum Power Dissipation (TDFN-4, P_D, T_A=25°C) ----- 390mW
- ◇ Thermal Resistance (TDFN-4, θ_{JA}) ----- 256°C/W

ESD Susceptibility

- ◇ HBM(Human Body Mode) ----- 2KV
- ◇ MM(Machine Mode) ----- 200V



Electrical Characteristics

$V_{IN} = V_{OUT} + 1V$, $C_{IN} = C_{OUT} = 1\mu F$, $T_A = 25^\circ C$, unless otherwise specified.

Symbol	Parameter	Test Conditions	Min	Typ	Max	Units
V_{IN}	Input Voltage		1.6		5.5	
ΔV_{OUT}	Output Voltage Accuracy	$I_{OUT} = 1mA$	-2	--	+2	%
I_{max}	Maximum output Current	$V_{EN} = V_{IN}$, $V_{IN} > 2.5V$		500		mA
I_{LIM}	Current Limit	$R_{LOAD} = 1\Omega$		650		mA
I_Q	Quiescent Current	$V_{EN} \geq 1.2V$, $I_{OUT} = 0mA$		20		μA
V_{DROP}	Dropout Voltage	$I_{OUT} = 200mA$, $V_{OUT} > 2.8V$		160	200	mV
		$I_{OUT} = 300mA$, $V_{OUT} > 2.8V$		240	300	mV
		$I_{OUT} = 500mA$, $V_{OUT} > 2.8V$		400	500	mV
ΔV_{LINE}	Line Regulation	$V_{IN} = (V_{OUT} + 1V)$ to 5.5V, $I_{OUT} = 1mA$			0.1	%
ΔV_{LOAD}	Load Regulation	$1mA < I_{OUT} < 300mA$			0.6	%
I_{STBY}	Standby Current	$V_{EN} = GND$, Shutdown		0.01	1	μA
I_{IBSD}	EN Input Bias Current	$V_{EN} = GND$ or V_{IN}		0.01	100	nA
V_{IL}	EN Threshold	Logic-Low Voltage $V_{IN} = 3V$ to 5.5V, Shutdown			0.4	V
V_{IH}		Logic-High Voltage $V_{IN} = 3V$ to 5.5V, Start-Up	1.4			V
-	Output Noise Voltage	$f = 10Hz$ to 100kHz, $I_{OUT} = 0mA$ $V_{OUT} = 2.8V$		100		$\mu VRMS$
PSRR	Power Supply Rejection Rate	$f=217Hz$		-80		dB
		$f=1KHz$	$C_{OUT} = 1\mu F$, $I_{OUT} = 50mA$	-76		dB
T_{SD}	Thermal Shutdown Temperature			150		$^\circ C$



Applications Information

Like any low-dropout regulator, the external capacitors used with the LP3980 must be carefully selected for regulator stability and performance. Using a capacitor whose value is $> 1\mu\text{F}$ on the LP3980 input and the amount of capacitance can be increased without limit. The input capacitor must be located a distance of not more than 0.5 inch from the input pin of the IC and returned to a clean analog ground. Any good quality ceramic or tantalum can be used for this capacitor. The capacitor with larger value and lower ESR (equivalent series resistance) provides better PSRR and line-transient response. The output capacitor must meet both requirements for minimum amount of capacitance and ESR in all LDOs application. The LP3980 is designed specifically to work with low ESR ceramic output capacitor in space-saving and performance consideration. Using a ceramic capacitor whose value is at least $1\mu\text{F}$ with ESR is $> 25\text{m}\Omega$ on the LP3980 output ensures stability. The LP3980 still works well with output capacitor of other types due to the wide stable ESR range. Figure 1 shows the curves of allowable ESR range as a function of load current for various output capacitor values. Output capacitor of larger capacitance can reduce noise and improve load transient response, stability, and PSRR. The output capacitor should be located not more than 0.5 inch from the VOUT pin of the LP3980 and returned to a clean analog ground.

Enable Function

The LP3980 features an LDO regulator enable/disable function. To assure the LDO regulator will switch on, the EN turn on control level must be greater than 1.2 volts. The LDO regulator will go into the shutdown mode when the voltage on the EN pin falls below 0.4 volts. For protecting the system, the LP3980 have a quick-discharge function. If the enable function is not needed in a specific application, it may be tied to VIN to keep the LDO regulator in a continuously on state.

Thermal Considerations

Thermal protection limits power dissipation in LP3980. When the operation junction temperature exceeds 150°C , the OTP circuit starts the thermal shutdown function turn the pass element off. The pass element turns on again after the junction temperature cools by 20°C . For continue operation, do not exceed absolute maximum operation junction temperature 125°C .

The power dissipation definition in device is :

$$P_D = (V_{IN} - V_{OUT}) \times I_{OUT} + V_{IN} \times I_Q$$

The maximum power dissipation depends on the thermal resistance of IC package, PCB layout, the rate of surroundings airflow and temperature difference between junctions to ambient.

The maximum power dissipation can be calculated by following formula:

$$P_{D(MAX)} = (T_{J(MAX)} - T_A) / \theta_{JA}$$



Where $T_{J(MAX)}$ is the maximum operation junction temperature 125°C, T_A is the ambient temperature and the θ_{JA} is the junction to ambient thermal resistance. For recommended operating conditions specification of LP3980, where $T_{J(MAX)}$ is the maximum junction temperature of the die (125°C) and T_A is the maximum ambient temperature. The junction to ambient thermal resistance (θ_{JA} is layout dependent) for SOT23-5 package is 250°C/W.

$$P_{D(MAX)} = (125^{\circ}\text{C} - 25^{\circ}\text{C}) / 250 = 400\text{mW (SOT23-5)}$$

The maximum power dissipation depends on operating ambient temperature for fixed $T_{J(MAX)}$ and thermal resistance θ_{JA} .





Packaging Information

SOT23-5

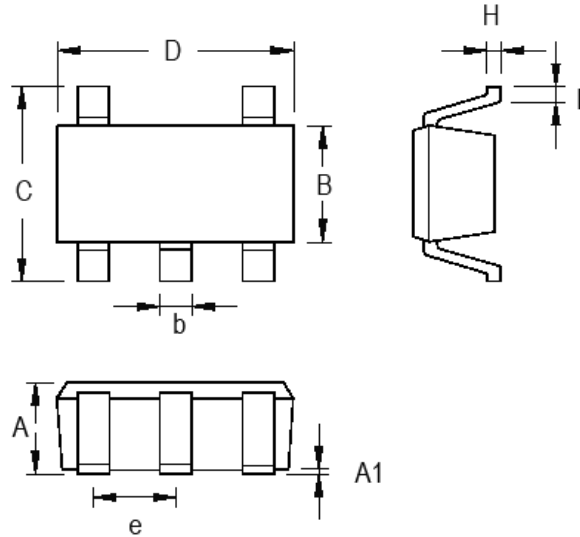

Symbol	Dimensions In Millimeters		Dimensions In Inches	
	Min	Max	Min	Max
A	0.889	1.295	0.035	0.051
A1	0.000	0.152	0.000	0.006
B	1.397	1.803	0.055	0.071
b	0.356	0.559	0.014	0.022
C	2.591	2.997	0.102	0.118
D	2.692	3.099	0.106	0.122
e	0.838	1.041	0.033	0.041
H	0.080	0.254	0.003	0.010
L	0.300	0.610	0.012	0.024

SOT-23-5 Surface Mount Package



SOT23

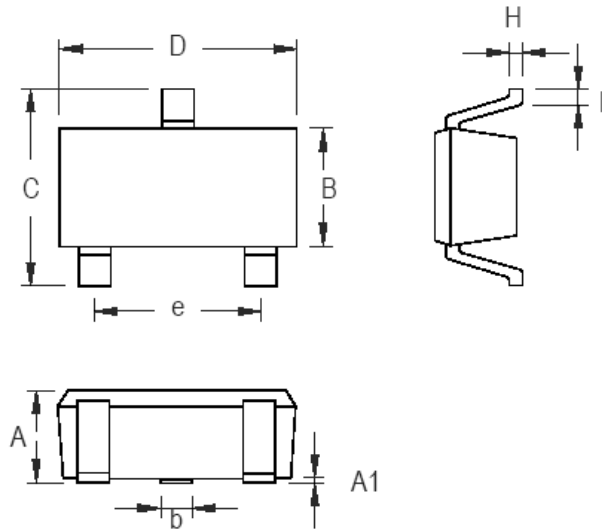

Symbol	Dimensions In Millimeters		Dimensions In Inches	
	Min	Max	Min	Max
A	0.889	1.295	0.035	0.051
A1	0.000	0.152	0.000	0.006
B	1.397	1.803	0.055	0.071
b	0.356	0.508	0.014	0.020
C	2.591	2.997	0.102	0.118
D	2.692	3.099	0.106	0.122
e	1.803	2.007	0.071	0.079
H	0.080	0.254	0.003	0.010
L	0.300	0.610	0.012	0.024

SOT-23 Surface Mount Package



TDFN-4

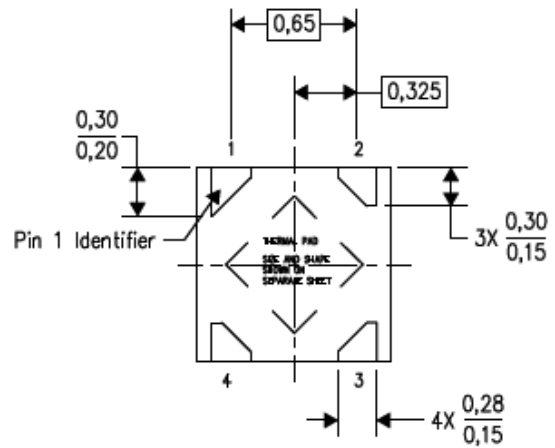
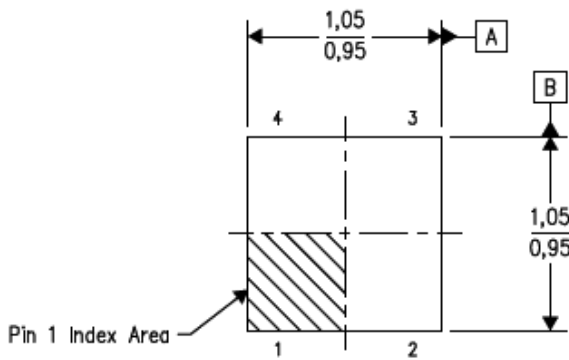

⊕	0,10	(M)	C	A	B
	0,05	(M)	C		

Bottom View

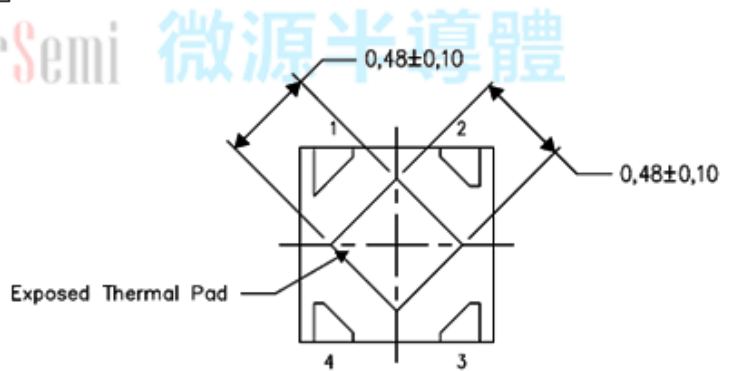
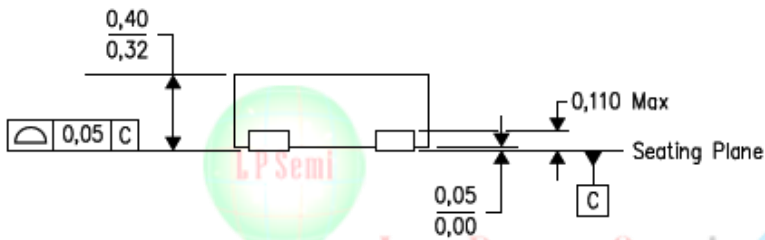

Bottom View

Exposed Thermal Pad Dimensions

X-ON Electronics

Largest Supplier of Electrical and Electronic Components

Click to view similar products for [LDO Voltage Regulators](#) category:

Click to view products by [LOWPOWER](#) manufacturer:

Other Similar products are found below :

[M38D29FFHP#U1](#) [702103A](#) [717726C](#) [742457H](#) [MP20051DN-LF-Z](#) [R5F111PGGFB#30](#) [AP7363-SP-13](#) [NCP103AMX285TCG](#)
[NCV8664CST33T3G](#) [NCV8752AMX28TCG](#) [L9454](#) [AP7362-HA-7](#) [LX13043CLD](#) [TCR3DF185,LM\(CT](#) [TCR3DF24,LM\(CT](#)
[TCR3DF285,LM\(CT](#) [TCR3DF31,LM\(CT](#) [TCR3DF45,LM\(CT](#) [TLF4949EJ](#) [L9708](#) [L970813TR](#) [030014BB](#) [059985X](#) [EAN61387601](#)
[EAN61573601](#) [NCP121AMX173TCG](#) [NCP4687DH15T1G](#) [NCV8703MX30TCG](#) [701326R](#) [702087BB](#) [755078E](#) [TCR2EN28,LF\(S](#)
[LM1117DT-1.8/NO](#) [LT1086CM#TRPBF](#) [AZ1085S2-1.5TRE1](#) [MAX15101EWL+T](#) [NCV8170AXV250T2G](#) [SCD337BTG](#)
[TCR3DF27,LM\(CT](#) [TCR3DF19,LM\(CT](#) [TCR3DF125,LM\(CT](#) [TCR2EN18,LF\(S](#) [MAX15103EWL+T](#) [TS2937CZ-5.0 C0](#) [MAX8878EUK30-](#)
[T](#) [MAX663CPA](#) [NCV4269CPD50R2G](#) [NCV8716MT30TBG](#) [AZ1117IH-1.2TRG1](#) [MP2013GQ-P](#)