



## 300mA, Ultra-low noise, Small Package Ultra-Fast CMOS LDO Regulator

### General Description

The LP3981 is designed for portable RF and wireless applications demanding performance and space requirements. The LP3981 performance is optimized for battery-powered systems to deliver ultra low noise and low quiescent current. Regulator ground current increases only slightly in dropout, further prolonging the battery life. The LP3981 also works with low-ESR ceramic capacitors, reducing the amount of board space necessary for power applications, critical in hand-held wireless devices. The LP3981 consumes less than 0.01 $\mu$ A in shutdown mode and has fast turn-on time less than 50 $\mu$ s. The other features include ultra low dropout voltage, high output accuracy, current limiting protection, and high ripple rejection ratio. It is available in 5-lead of SOT23-5 packages.

### Order Information

LP3981	□ □ □ □ □	
		F: Pb-Free
		Package Type
		B5: SOT23-5
		Output Voltage Type
	12:	1.2V
	13:	1.3V
	15:	1.5V
	18:	1.8V
	25:	2.5V
	28:	2.8V
	30:	3.0V
	33:	3.3V

### Features

- ◆ Ultra-Low-Noise for RF Application
- ◆ 2V- 6.5V Input Voltage Range
- ◆ Low Dropout : 220mV @ 300mA
- ◆ 1.2V, 1.5V, 1.8V, 2.5V, 2.8V 3.0V and 3.3V Fixed
- ◆ 300mA Output Current, 550mA Peak Current
- ◆ High PSSR:-76dB at 1KHz
- ◆ < 0.01uA Standby Current When Shutdown
- ◆ Available in SOT23-5 Package
- ◆ TTL-Logic-Controlled Shutdown Input
- ◆ Ultra-Fast Response in Line/Load transient
- ◆ Current Limiting and Thermal Shutdown Protection
- ◆ Quick start-up (typically 50uS)

### Applications

- ◇ Portable Media Players/MP3 players
- ◇ Cellular and Smart mobile phone
- ◇ LCD
- ◇ DSC Sensor
- ◇ Wireless Card

### Typical Application Circuit

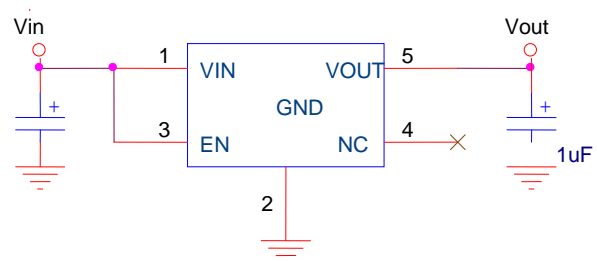

### Marking Information

Device	Marking	Package	Shipping
LP3981		SOT23-5	3K/REEL

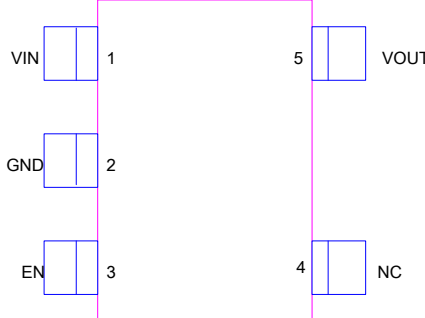

### Functional Pin Description

Package Type	Pin Configurations
SOT23-5	<p>Top View</p> 

### Pin Description

Pin	Name	Description
1	VIN	Power Input Voltage
2	GND	Ground
3	EN	Chip Enable (Active High). Note that this pin is high impedance. There should be a pull low 100kΩ resistor connected to GND when the control signal is floating.
4	NC	NC
5	VOUT	Output Voltage

### Function Diagram

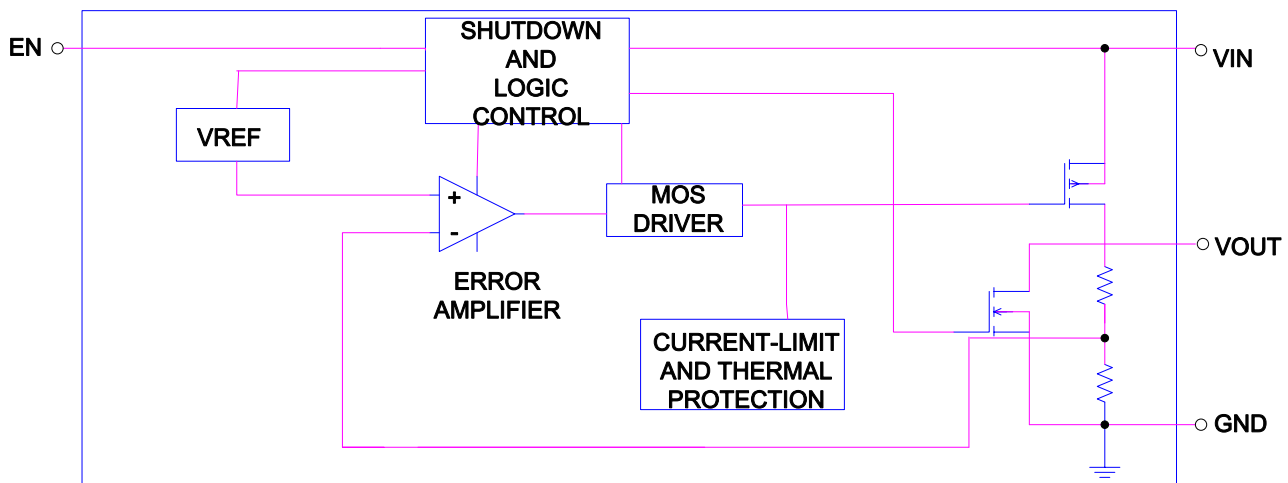



## Absolute Maximum Ratings

- ◇ Supply Input Voltage ----- 6V
- ◇ Power Dissipation, PD @ TA = 25°C SOT-25 ----- 400mW
- ◇ Package Thermal Resistance SOT-25,  $\theta_{JA}$  ----- 250°C/W
- ◇ Lead Temperature (Soldering, 10 sec.) ----- 260°C
- ◇ Storage Temperature Range ----- -65°C to 150°C

### ESD Susceptibility

- ◇ HBM (Human Body Mode) ----- 2kV
- ◇ MM(Machine-Mode) ----- 200V

### Recommended Operating Conditions

- ◇ Supply Input Voltage ----- 2.5V to 5.5V
- ◇ EN Input Voltage ----- 0V to 5.5V
- ◇ Operation Junction Temperature Range ----- -40°C to 125°C
- ◇ Operation Ambient Temperature Range ----- -40°C to 85°C

## Electrical Characteristics

(VIN = VOUT + 1V, CIN = COUT = 1 $\mu$ F, , TA = 25° C, unless otherwise specified)

Parameter	Symbol	Test Conditions	Min	Typ	Max	Units
Output Voltage Accuracy	$\Delta V_{OUT}$	$I_{OUT} = 1mA$	-2	--	+2	%
Maximum output Current	$I_{max}$	$V_{EN}=V_{IN}, V_{IN}>2.5V$		300		mA
Current Limit	$I_{LIM}$	$R_{LOAD} = 1\Omega$	360	400		mA
Quiescent Current	$I_Q$	$V_{EN} \geq 1.2V, I_{OUT} = 0mA$		45	120	$\mu A$
Dropout Voltage	$V_{DROP}$	$I_{OUT} = 200mA, V_{OUT} > 2.8V$		170	200	mV
		$I_{OUT} = 300mA, V_{OUT} > 2.8V$		220	300	mV
Line Regulation	$\Delta V_{LINE}$	$V_{IN} = (V_{OUT} + 1V) \text{ to } 5.5V, I_{OUT} = 1mA$			0.3	%
Load Regulation	$\Delta V_{LOAD}$	$1mA < I_{OUT} < 300mA$			2	%
Standby Current	$I_{STBY}$	$V_{EN} = GND, \text{ Shutdown}$		0.01	1	$\mu A$
EN Input Bias Current	$I_{IBSD}$	$V_{EN} = GND \text{ or } V_{IN}$		0.01	100	nA
EN Threshold	Logic-Low Voltage	$V_{IL}$			0.4	V
	Logic-High Voltage	$V_{IH}$		1.2		V
Output Noise Voltage		10Hz to 100kHz, $I_{OUT}=200mA$ $C_{OUT}=1\mu F$		100		$\mu VRMS$
Power Supply Rejection Rate	f=100Hz	PSRR	$C_{OUT}=1\mu F, I_{OUT}=50mA$	-76		dB
	f=10kHz			-73		dB
Thermal Shutdown Temperature	$T_{SD}$			150		°C



## Typical Operating Characteristics

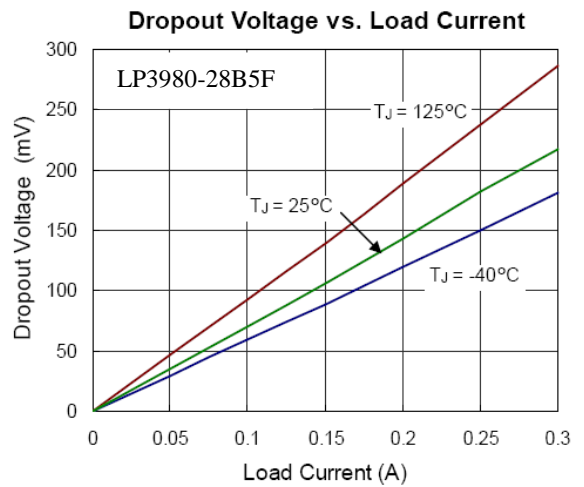
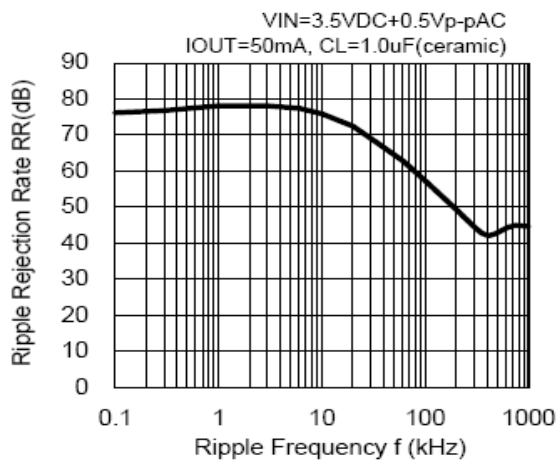
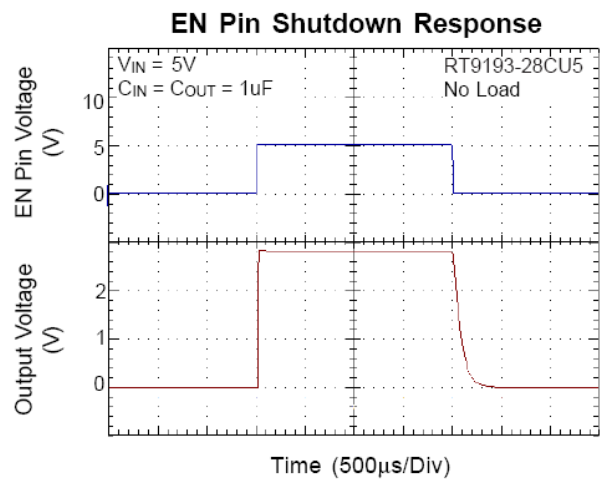
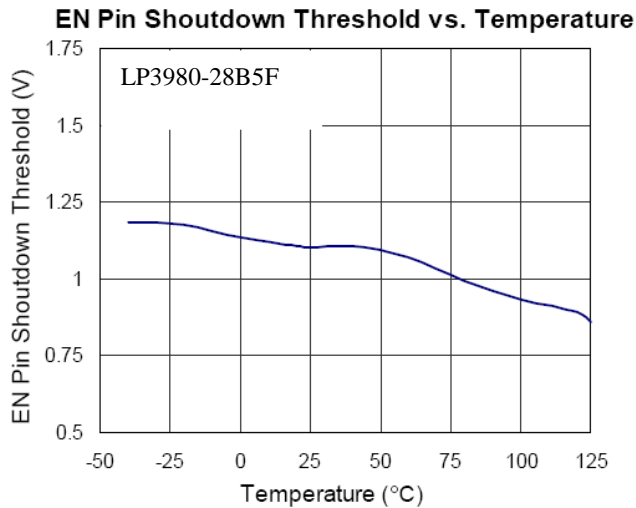
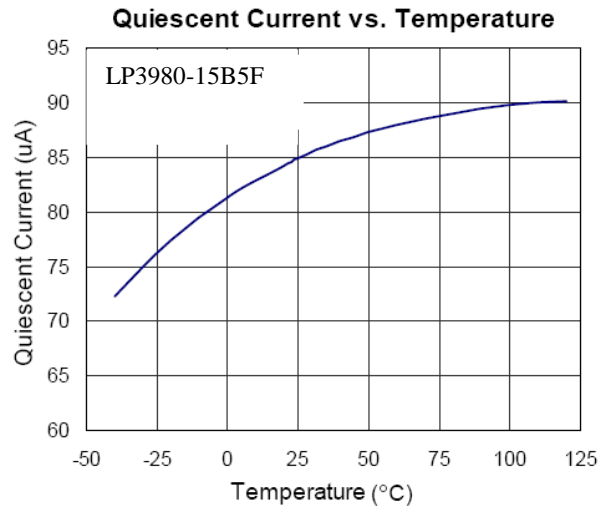
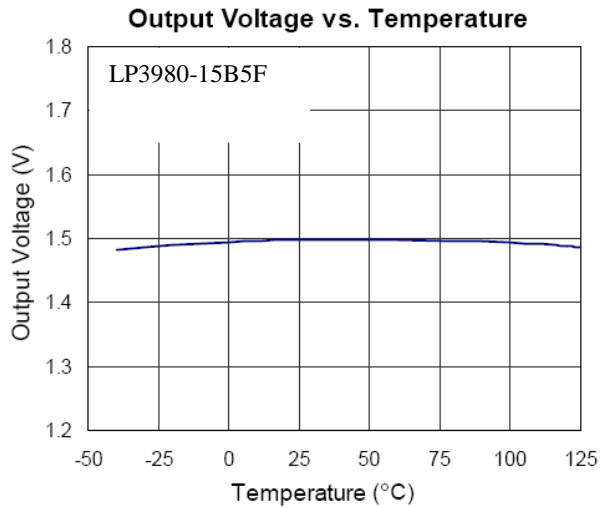



## Applications Information

Like any low-dropout regulator, the external capacitors used with the LP3981 must be carefully selected for regulator stability and performance. Using a capacitor whose value is  $> 1\mu\text{F}$  on the LP3981 input and the amount of capacitance can be increased without limit. The input capacitor must be located a distance of not more than 0.5 inch from the input pin of the IC and returned to a clean analog ground. Any good quality ceramic or tantalum can be used for this capacitor. The capacitor with larger value and lower ESR (equivalent series resistance) provides better PSRR and line-transient response. The output capacitor must meet both requirements for minimum amount of capacitance and ESR in all LDOs application. The LP3981 is designed specifically to work with low ESR ceramic output capacitor in space-saving and performance consideration. Using a ceramic capacitor whose value is at least  $1\mu\text{F}$  with ESR is  $> 25\text{m}\Omega$  on the LP3981 output ensures stability. The LP3981 still works well with output capacitor of other types due to the wide stable ESR range. Figure 1 shows the curves of allowable ESR range as a function of load current for various output capacitor values. Output capacitor of larger capacitance can reduce noise and improve load transient response, stability, and PSRR. The output capacitor should be located not more than 0.5 inch from the VOUT pin of the LP3981 and returned to a clean analog ground.

### Start-up Function Enable Function

The LP3981 features an LDO regulator enable/disable function. To assure the LDO regulator will switch on, the EN turn on control level must be greater than 1.2 volts. The LDO regulator will go into the shutdown mode when the voltage on the EN pin falls below 0.4 volts. For protecting the system, the LP3981 have a quick-discharge function. If the enable function is not needed in a specific application, it may be tied to VIN to keep the LDO regulator in a continuously on state.

### Thermal Considerations

Thermal protection limits power dissipation in LP3981. When the operation junction temperature exceeds  $150^{\circ}\text{C}$ , the OTP circuit starts the thermal shutdown function turn the pass element off. The pass element turns on again after the junction temperature cools by  $25^{\circ}\text{C}$ . For continue operation, do not exceed absolute maximum operation junction temperature  $125^{\circ}\text{C}$ .

The power dissipation definition in device is :

$$PD = (VIN - VOUT) \times IO_{OUT} + VIN \times IQ$$

The maximum power dissipation depends on the thermal resistance of IC package, PCB layout, the rate of surroundings airflow and temperature difference between junction to ambient.

The maximum power dissipation can be calculated by following formula :

$$PD(\text{MAX}) = (TJ(\text{MAX}) - TA) / \theta_{JA}$$



### Packaging Information

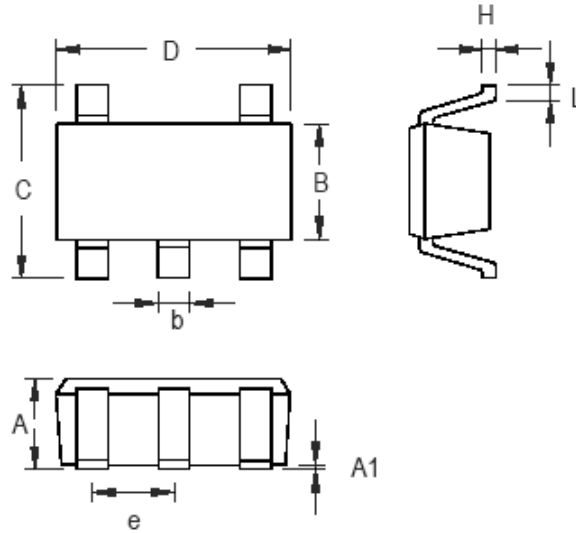

Symbol	Dimensions In Millimeters		Dimensions In Inches	
	Min	Max	Min	Max
A	0.889	1.295	0.035	0.051
A1	0.000	0.152	0.000	0.006
B	1.397	1.803	0.055	0.071
b	0.356	0.559	0.014	0.022
C	2.591	2.997	0.102	0.118
D	2.692	3.099	0.106	0.122
e	0.838	1.041	0.033	0.041
H	0.080	0.254	0.003	0.010
L	0.300	0.610	0.012	0.024

**SOT- 25 Surface Mount Package**

## X-ON Electronics

Largest Supplier of Electrical and Electronic Components

*Click to view similar products for [Linear Voltage Regulators](#) category:*

*Click to view products by [LOWPOWER](#) manufacturer:*

Other Similar products are found below :

[LV56831P-E](#) [LV5684PVD-XH](#) [MCDTSA6-2R](#) [L7815ACV-DG](#) [PQ3DZ53U](#) [LV56801P-E](#) [TLE42794G](#) [L78L05CZ/1SX](#) [L78LR05DL-MA-E](#) [636416C](#) [714954EB](#) [BA033LBSG2-TR](#) [LV5680P-E](#) [L78M15CV-DG](#) [L79M05T-E](#) [TLS202A1MBVHTSA1](#) [L78LR05D-MA-E](#) [NCV317MBTG](#) [NTE7227](#) [LV5680NPVC-XH](#) [LT1054CN8](#) [MP2018GZD-5-Z](#) [MP2018GZD-33-Z](#) [MIC5281-3.3YMM](#) [MC78L06BP-AP](#) [TA48LS05F\(TE85L,F\)](#) [TA78L12F\(TE12L,F\)](#) [TC47BR5003ECT](#) [TCR2LN12,LF\(S](#) [TCR2LN28,LF\(S](#) [TCR2LN30,LF\(S](#) [TCR3DF295,LM\(CT](#) [TCR3DF40,LM\(CT](#) [BA178M20CP-E2](#) [L78M12ABDT](#) [LM7812SX/NOPB](#) [LR645N3-G-P003](#) [LR645N3-G-P013](#) [ZXTR2005P5-13](#) [SCD7812BTG](#) [TCR3DF335,LM\(CT](#) [ZXTR2012K-13](#) [TLE42994E V33](#) [ZXTR2008K-13](#) [ZXTR2005K-13](#) [L88R05DL-E](#) [ADP3300ARTZ-2.7RL7](#) [LM120K-15/883](#) [IFX54441LDVXUMA1](#) [LM317D2T-TR](#)