



500mA Single Chip Li-Ion and Li-Polymer Charger

General Description

The LP4063S is a complete constant-current/ constant voltage linear charger for single cell lithium-ion battery. Its SOT23-5 package and low external component count make the LP4063S ideally suited for portable applications. No external sense resistor is needed, and no blocking diode is required due to the internal MOSFET architecture. Thermal feedback regulates the charge current to limit the die temperature during high power operation or high ambient temperature. The charge voltage is fixed at 4.2V, and the charge current can be ISET programmed externally with a single resistor.

The LP4063S automatically terminates the charge cycle when the charge current drops to 1/10 setting current value after the final float voltage is reached.

When the input supply is removed, the LP4063S automatically enters a low current state, dropping the battery drain current to less than $< 1\mu\text{A}$.

Other features include charge current monitor, under voltage lockout, automatic recharge and a status pin .

Order Information

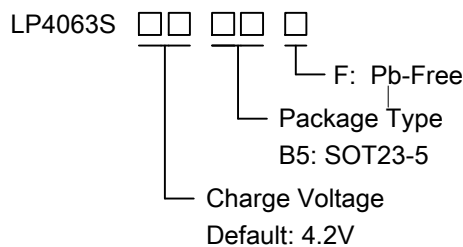

Applications

- ✧ Portable Media Players/Game
- ✧ Power Bank
- ✧ Bluetooth Applications
- ✧ PDA/MID

Features

- ◆ Input Voltage up to 28V
- ◆ Input Over Voltage Protection : 7V
- ◆ Short-circuit protection
- ◆ Programmable Charge Current:50mA to 500mA
- ◆ $< 1\mu\text{A}$ Battery Reverse Current
- ◆ Protection of Reverse Connection of Battery
- ◆ No MOSFET, Sense Resistor or Blocking Diode Required
- ◆ Constant-Current/Constant-Voltage Operation with Thermal Regulation to Maximize Charge Rate Without Risk of Overheating
- ◆ SOT23-5 Package
- ◆ RoHS Compliant and 100% Lead (Pb)-Free

Typical Application Circuit

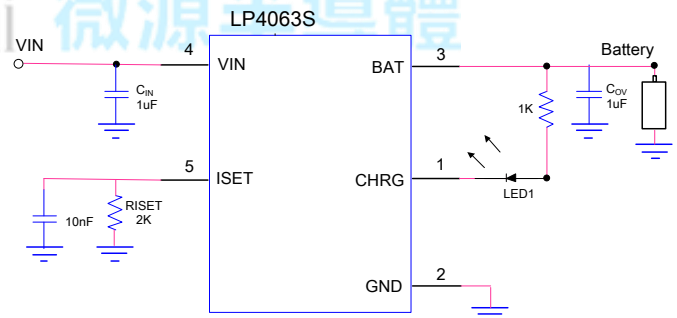

Marking Information

Device	Marking	Package	Shipping
LP4063SB5F	LP4063 SYWX	SOT23-5	3K/REEL
Marking indication: Y:Production year W:Production week X: Series Number			



Functional Pin Description

Package Type	Pin Configurations
SOT23-5	<p style="text-align: center;">SOT23-5 TOP VIEW</p>

Pin Description

No.	NAME	DESCRIPTION
1	CHRG	Open-Drain Charge Status Output. When the battery is charging, the CHRG pin is pulled low by an internal NMOS. When the charge cycle is completed, the pin could be pulled High by an external pull high resistor.
2	GND	GND is the connection to system ground.
3	BAT	BAT is the connection to the battery. Typically a 10μF Tantalum capacitor is needed for stability when there is no battery attached. When a battery is attached, only a 1uF ceramic capacitor is required.
4	VIN	VIN is the input power source. Connect to a wall adapter.
5	ISET	Charge Current Program. The charge current is programmed by connecting a 1% resistor(R_{ISET}) to ground. $I_{BAT} = \frac{1300 \times V_{ISET}}{R_{ISET}}$



Function Block Diagram

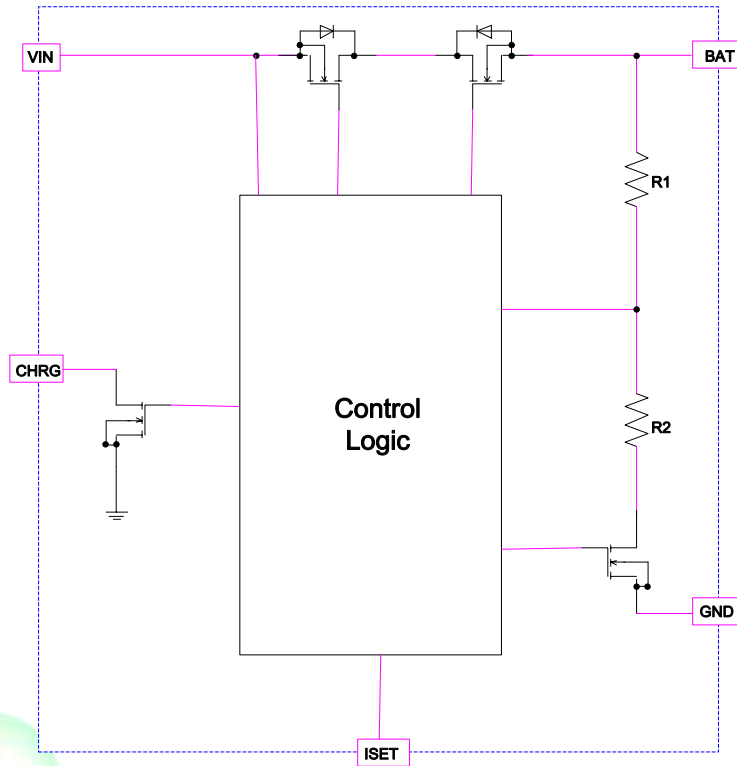

Absolute Maximum Ratings ^{Note 1}

- ✧ Input Voltage to GND ----- -0.3V to 28V
- ✧ BAT Voltage GND ----- - 5V to 6.5V
- ✧ Other pin to GND ----- -0.3V to 6.5V
- ✧ Maximum Junction Temperature ----- 125°C
- ✧ Maximum Soldering Temperature (at leads, 10 sec) ----- 260°C
- ✧ Operating Junction Temperature Range (T_J) ----- -40°C to 85°C
- ✧ Storage Temperature ----- -65°C to 165°C

Thermal Information

- ✧ Maximum Power Dissipation (P_D, T_A=25°C) ----- 0.6W
- ✧ Thermal Resistance (θ_{JA}) ----- 200°C/W

ESD Susceptibility

- ✧ HBM(Human Body Mode) ----- 2KV
- ✧ MM(Machine Mode) ----- 200V

Note 1. Stresses beyond those listed under “Absolute Maximum Ratings” may cause permanent damage to the device. These are stress ratings only, and functional operation of the device at these or any other conditions beyond those indicated in the operational sections of the specifications is not implied. Exposure to absolute maximum rating conditions for extended periods may affect device reliability.



Electrical Characteristics

($T_A=25^{\circ}\text{C}$, $V_{IN}=5\text{V}$, unless otherwise noted.)

SYMBOL	PARAMETER	CONDITIONS	MIN	TYP.	MAX	UNITS
V_{IN}	Input Voltage		4.4	5	6.5	V
I_{IN}	Input Supply Current	$I_{BAT}=0$		1000		μA
V_{FLOAT}	Regulated Output (Float) Voltage	$I_{BAT}=40\text{mA}$,	4.158	4.2	4.242	V
V_{OVP}	Input Voltage OVP	V_{IN} Rising		7		V
V_{OVP_HYS}	OVP Hysteresis			150		mV
I_{BAT}	BAT Pin Current	$R_{ISET}=4\text{k}$, Current Mode		325		mA
		$R_{ISET}=10\text{k}$, Current Mode		130		mA
		$V_{BAT}=4.2\text{V}$		1		μA
		$V_{IN}=\text{float or }0\text{V}$		1		
I_{TRIKL}	Trickle Charge Current	$V_{BAT}<V_{TRIKL}$, $R_{ISET}=1\text{k}$, Current Mode		10		% I_{BAT}
V_{TRIKL}	Trickle Charge Threshold Voltage	V_{BAT} Rising		2.6		V
V_{TRHYS}	Trickle Charge Hysteresis Voltage			150		mV
I_{TERM}	Termination Current Threshold			20		% I_{BAT}
V_{ISET}	ISET Pin Voltage	Current Mode		1		V
I_{CHRG}	CHRG Pin Weak Pull-Down Current	$V_{CHRG}=5\text{V}$			5	μA
V_{CHRG}	CHRG Pin Output Low Voltage	$I_{CHRG}=5\text{mA}$			0.1	V
ΔV_{RECHRG}	Recharge Battery Threshold Voltage	$V_{FLOAT}-V_{RECHRG}$		150		mV
T_{LIM}	Junction Temperature in Constant Temperature Mode			125		$^{\circ}\text{C}$



Application Information

Input Voltage Range

The LP4063S has built-in input voltage surge protection as high as +28V. The charger IC will be automatically disabled when the input voltage is lower than 4.4V or higher than 7.0V. A charge cycle begins when the voltage at the VIN pin rises above the 4.4V level, when a battery is connected to the charger output. If the BAT pin is less than 2.6V, the charger enters trickle charge mode. In this mode, the LP4063S supplies approximately 1/10 the ISET programmed charge current to bring the battery voltage up to a safe level for full current charging. When the BAT pin voltage rises above 2.6V, the charger enters constant-current mode(CC), where the ISET programmed charge current is supplied to the battery. When the BAT pin approaches the final float voltage, the LP4063S enters constant-voltage mode(CV) and the charge current begins to decrease, and the battery full indication is set when the charge current in the CV mode is reduced to the programmed full battery current (1/10).

Charge Termination

A charge cycle is terminated when the charge current falls to 1/10th the ISET programmed value after the final float voltage is reached. This condition is detected by using an internal, filtered comparator to monitor the ISET pin. When the ISET pin voltage falls below 100mV for longer than tTERM (typically 1ms), charging is terminated.

ISET programming Charge Current

The charge current (IBAT) is set by a resistor (RISET) connecting from the ISET pin to GND. The relationship of the charge current and the programming resistance is established by the following equations (V ISET=1V).

$$I_{BAT} = \frac{1300 \times V_{ISET}}{R_{ISET}}$$

Automatic Recharge

Once the charge cycle is terminated, the LP4063S continuously monitors the voltage on the BAT pin. A charge cycle restarts when the battery voltage falls below 4.05V (which corresponds to approximately 80% to 90% battery capacity). This ensures that the battery is kept at or near a fully charged condition and eliminates the need for periodic charge cycle initiations.

Charge Status Indicator(CHRG)

The charge status output has two different states: strong pull-down (~5mA) and high impedance. The strong pull-down state indicates that the LP4063S is in a charge cycle. High impedance indicates that the charge cycle complete or the LP4063S is in under voltage lockout mode: either insufficient voltage is applied to the VCC pin or VCC pin voltage higher than OVP.

Function	CHRG
Charging	Low
Charge Finish	High

Thermal Limiting

An internal thermal feedback loop reduces the ISET programmed charge current if the die temperature attempts to rise above a preset value of approximately 125°C. This feature protects the LP4063S from excessive temperature and allows the user to push the limits of the power handling capability of a given circuit board without risk of damaging the LP4063S. The charge current can be set according to typical (not worst-case) ambient temperature with the assurance that the charger will automatically reduce the current in worst-case conditions.



Packaging Information

SOT23-5

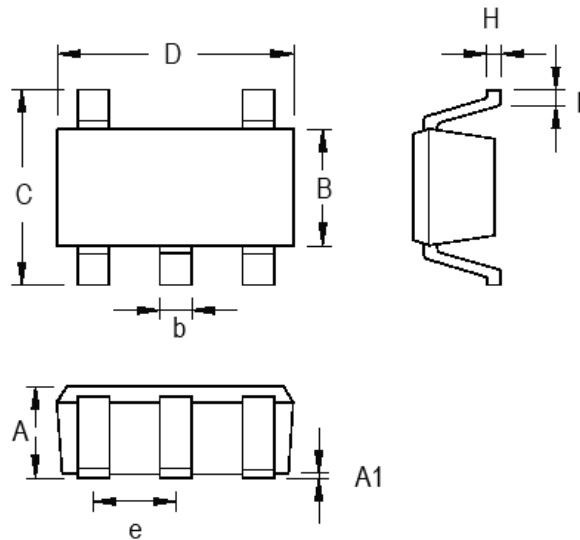

Symbol	Dimensions In Millimeters		Dimensions In Inches	
	Min	Max	Min	Max
A	0.889	1.295	0.035	0.051
A1	0.000	0.152	0.000	0.006
B	1.397	1.803	0.055	0.071
b	0.356	0.559	0.014	0.022
C	2.591	2.997	0.102	0.118
D	2.692	3.099	0.106	0.122
e	0.838	1.041	0.033	0.041
H	0.080	0.254	0.003	0.010
L	0.300	0.610	0.012	0.024

SOT-23-5 Surface Mount Package

X-ON Electronics

Largest Supplier of Electrical and Electronic Components

Click to view similar products for [Battery Management](#) category:

Click to view products by [LOWPOWER](#) manufacturer:

Other Similar products are found below :

[MP2602DQ-LF-P](#) [MP26053DQ-LF-Z](#) [MP2611GL-P](#) [NCP347MTAHTBG](#) [LM3658SD-AEV/NOPB](#) [MP2607DL-LF-P](#) [MP26121DQ-LF-P](#)
[MP26123DR-LF-P](#) [MP2633GR-P](#) [MP2637GR-P](#) [BQ24212EVM-678](#) [NCP1855FCCT1G](#) [MP2636GR-P](#) [FAN54063UCX](#)
[MAX14680EWC+T](#) [MAX14634EWC+T](#) [DS2745U+T&R](#) [MAX14578EETE+T](#) [DS2781EVKIT+](#) [DS2781E+T&R](#) [MP2605DQ-LF-P](#)
[DS2710G+T&R](#) [MAX17040G+T](#) [MAX14525ETA+T](#) [MP2615GQ-P](#) [MAX14578EEWC+T](#) [LC05132C01NMTTGTG](#) [MAX8971EWP+T](#)
[MAX14630EZK+T](#) [MAX1873TEEE+T](#) [PSC5415A](#) [AUR9811DGD](#) [SN2040DSQR](#) [DS2715BZ+T&R](#) [MAX1508ZETA+T](#)
[MAX14921ECS+T](#) [MAX77301EWA+T](#) [BD8668GW-E2](#) [MAX16024PTBS+T](#) [DS2715Z+T&R](#) [MAX16024LTBZ18+T](#) [DS2782E+T&R](#)
[DS2782G+T&R](#) [MAX1908ETI+T](#) [ISL95522IRZ](#) [ISL95522HRZ](#) [ARD00558](#) [NCP4371AAEDR2G](#) [BD8665GW-E2](#) [MAX8934EETI+T](#)