



Over Voltage Protection IC

General Description

The LP5300C is a highly integrated circuits, it used to protect low voltage system from abnormal high input voltage. When the protection status is occur, the power MOS will turn off at the same time. The LP5300C is safety devices to ensure worked against accidents. In case of the input voltage exceeds a OVP threshold voltage level, the power MOS will turn off within 1 μ s. Other features include over temperature protection and under-voltage lockout (UVLO). The LP5300C is available in a space saving SOT23-6 package.

Order Information

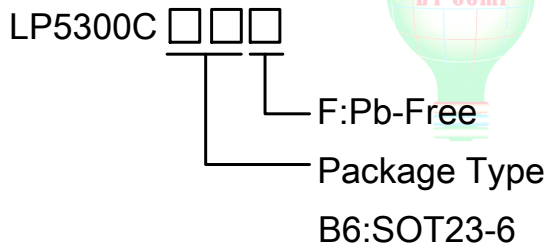

Applications

- ◆Cell Phones
- ◆Digital Cameras
- ◆Portable Instruments

Features

- ◆Withstand High Input Voltage Up to 26V
- ◆Input Over Voltage Protection
- ◆High Accuracy Protection Thresholds
- ◆Under Voltage Lockout
- ◆Over-Temperature Protection
- ◆Available in SOT23-6
- ◆RoHS Compliant and Halogen Free

Typical Application Circuit

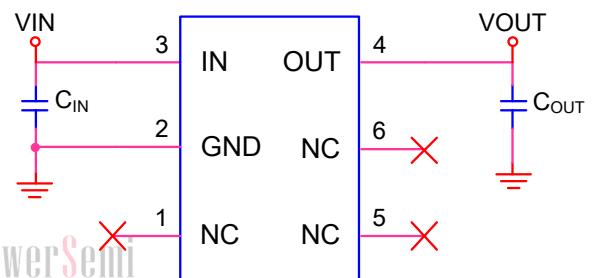

Marking Information

Device	Marking	Package	Shipping
LP5300C	LP5300 8WYW X	SOT23-6	3K/REEL

8W: Fixed Code
Y: Year Code W: Week Code X: series number.



Pin Configuration

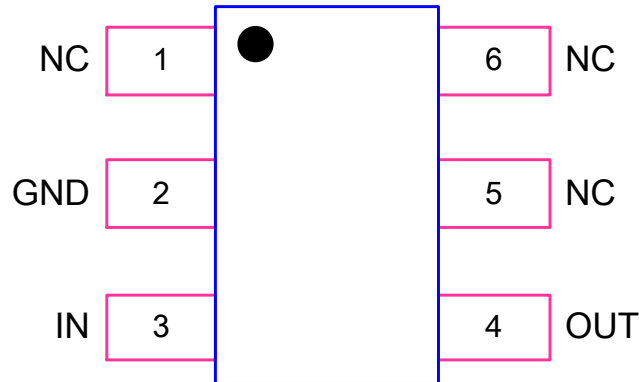

Function Block Diagram

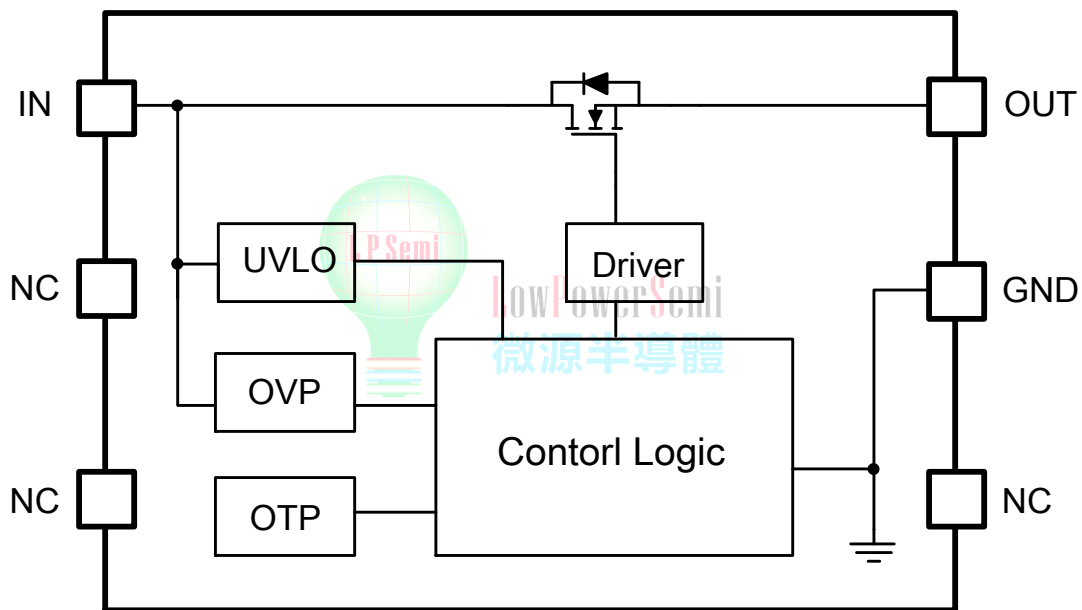

Functional Pin Description

Name	Pin	Description
NC	1	No Connect
GND	2	Ground.
VIN	3	Power source input. Connect a ceramic capacitor between VIN and GND
OUT	4	Output through the power MOSFET.
NC	5	No Connect
NC	6	No Connect



Absolute Maximum Ratings ^{Note1}

◇ Input to GND	-----	-0.3V to 30V
◇ OUT to GND	-----	-0.3V to 7V
◇ Operating Junction Temperature Range (TJ)	-----	-40°C to 150°C
◇ Operation Ambient Temperature Range	-----	-40°C to 105°C
◇ Storage Temperature Range	-----	65°C to 150°C
◇ Maximum Soldering Temperature (at leads, 10 sec)	-----	260°C

Note1. Stresses beyond those listed under "Absolute Maximum Ratings" may cause permanent damage to the device. These are stress ratings only, and functional operation of the device at these or any other conditions beyond those indicated in the operational sections of the specifications is not implied. Exposure to absolute maximum rating conditions for extended periods may affect device reliability.

Thermal Information

◇ Maximum Power Dissipation (PD, TA=25°C)	-----	0.45W
◇ Thermal Resistance (JA)	-----	250°C/W

ESD Susceptibility

◇ HBM(Human Body Mode)	-----	2KV
◇ MM(Machine Mode)	-----	200V





Electrical Characteristics

($V_{IN} = 5V$, $T_A = 25^\circ C$, Unless Otherwise Specified)

Parameter	Symbol	Test Conditions	Min	Typ	Max	Units
General Function						
Power Source Voltage	V_{IN}	$T_J = +25^\circ C$	3.3	5	26	V
Input UVLO Threshold	V_{UVLO}	V_{IN} Rising	2.5	2.7	2.9	V
UVLO Threshold Hysteresis	ΔV_{UVLO}	Falling Hysteresis		200		mV
Soft Start Time	T_{SS}			9		ms
Power Source Current	I_{IN}	$V_{IN}=5V$		2.4		mA
Thermal Shutdown Threshold	T_{SD}			140		$^\circ C$
Thermal Shutdown Threshold Hysteresis	ΔT_{SD}			20		$^\circ C$
Power MOS						
Switch On Resistance	$R_{DS(ON)}$	$I_{OUT}=1A$		184		m Ω
Regulation Function						
Output Voltage Regulation	V_{LDO}	$V_{IN}=5.7V$		5.5		V
Protection Functions						
Input Over Voltage Protect threshold	V_{IOVP}	V_{IN} from 5V to 10V	5.7	5.85	6.0	V
Input OVP propagation delay	T_{OVP}				0.8	us
Input OVP threshold Hysteresis	ΔV_{IOVP}	V_{IN} from 10V to 5V		100		mV



Application Information

The LP5300C devices monitor the input voltage to protect the charging system of a Li-Ion battery. When protect circuits enabled, the system is protected against input overvoltage by turning off an internal switch, immediately removing power from the charging circuit. Additionally, the device also monitors its own temperature and switches off if device too hot.

Under Voltage Lockout (UVLO)

The LP5300C had an UVLO internal circuit that enables the device once the voltage on the VIN voltage exceeds the UVLO threshold voltage.

Input Over Voltage Protection

The LP5300C Input has an over voltage protection to protect the battery charging system. When the VIN voltage rises above Input Voltage Protect threshold, the system will turns the switch off.

Over Temperature Protection

The LP5300C device enters over temperature protection(OTP) if its junction temperature exceeds 140°C (Typ.). During over temperature protection none of the device's functions are available. To resume normal operation the junction temperature need cool down, and the outputs will restart.

Layout Consideration

The proper PCB layout and component placement are critical for all circuit. LP5300C is meant to protect downstream circuit. Here are some suggestions to the layout design.

1. Connected all ground together with one uninterrupted ground plane, which include power ground and analog ground.
2. The input and output capacitor should be located as closed as possible to the chip and ground plane.
3. Other components should be located close to the chip.



Packaging Information

SOT23-6

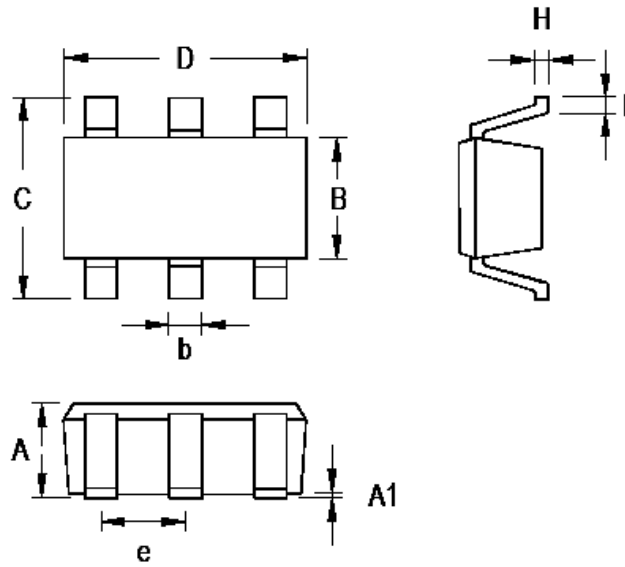

Symbol	Dimensions In Millimeters		Dimensions In Inches	
	Min	Max	Min	Max
A	0.889	1.295	0.031	0.051
A1	0.000	0.152	0.000	0.006
B	1.397	1.803	0.055	0.071
b	0.250	0.560	0.010	0.022
C	2.591	2.997	0.102	0.118
D	2.692	3.099	0.106	0.122
e	0.838	1.041	0.033	0.041
H	0.080	0.254	0.003	0.010
L	0.300	0.610	0.012	0.024

X-ON Electronics

Largest Supplier of Electrical and Electronic Components

Click to view similar products for [Surge Suppressors](#) category:

Click to view products by [LOWPOWER](#) manufacturer:

Other Similar products are found below :

[2800521](#) [GUS11](#) [GUS4](#) [30460](#) [IE103](#) [SRA64C060X](#) [PC642C015](#) [1810-15-A3](#) [2713175](#) [4B06B-EC1-150LF](#) [SRA6LC](#) [CX06M](#) [CCTV1](#)
[GUS13](#) [GUS14](#) [GUS5](#) [VAL-MS 320/3+0-FM](#) [TTC-6-1X2-M-24DC-UT-I](#) [TTC-6P-1X2-24DC-UT-I](#) [TTC-6P-1X2-M-24DC-UT-I](#) [VAL-US-](#)
[120/40/1+1-FM](#) [VAL-US-120/65/1+1-FM](#) [VAL-US-480D/30/3+0-FM](#) [VAL-US-120/40/1+0-FM](#) [STCHSP121BT1RU](#) [LP-GTR-NFF](#) [LP-](#)
[BFDN-CW](#) [LP-STRL-NFF](#) [LP-STRL-DFE](#) [0804111](#) [5053609](#) [5053201](#) [SPD2-550-1P0](#) [1-2191595-2](#) [STC-CAT6-P0E-I](#) [SPD2-350-1P0](#)
[FLT-CP-350-ST](#) [TTC-6P-3-HF-F-M-12DC-UT-I](#) [LTC4364CMS-1#TRPBF](#) [DS71RS-120](#) [P8AX09-T/MF](#) [CRMJ8-POE-C6](#) [DS42S-48DC](#)
[MJ8-CAT6S](#) [DS41S-280](#) [3414.99.0021](#) [3414.99.0008](#) [STCSS640362](#) [NRPS10-5A](#) [1251-240S-N1](#)