



Features

- Input voltage tolerance up to 36V
- Low on-state resistance to 135mΩ
- 90μA low current consumption
- Adjustable OCP: 0.2A to 2.5A
- Under-voltage lockout: 2.7V
- Over-voltage protection: 5.85V
- Output discharge integrated
- Thermal shutdown protection
- ESD Protection:
 - Human Body Model: 4kV
 - Charged Device Model: 0.5kV
- Package: SOT23-6 and DFN-8

Applications

- Notebook and PC
- Cell phone and PDAs
- USB or other peripheral ports
- Camera

General Description

The LP5308 is a power switch device provides full protection to systems and loads which may encounter large current and input over-voltage conditions.

The device contains a 135mΩ MOSFET which can operate over an input voltage range from 3.0V to 36V. The OVP will disconnect VIN and VOUT when the voltage on VIN is higher than over voltage threshold. The over-current protection could be settable using an external resistor. When the current reaches the threshold, the device will turn off the power FET to prohibit excessive currents from causing damage. Switch is controlled by an active-low logic pin. Thermal shutdown protection is integrated which shuts off the switch to prevent damage to the part when the temperature is higher than threshold.

These parts are available in space-saving SOT23-6 package and DFN-8 package.



SOT23-6

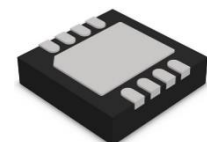

DFN-8

Marking Information

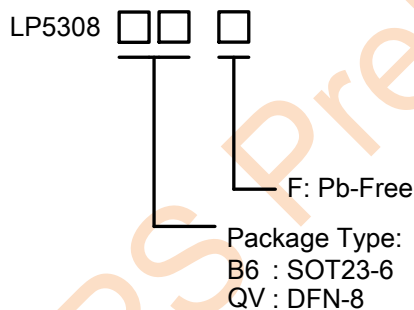

Ordering and Package Information

Part Number	Top Mark	Package	Tape & Reel
LP5308QVF	LPS LP5308 YWX	DFN-8	4K/REEL
LP5308B6F	LP5308 YWX	SOT23-6	3K/REEL
Marking indication: Y: Production Year, W: Production week, X: Series Number			



Typical Application Circuitry

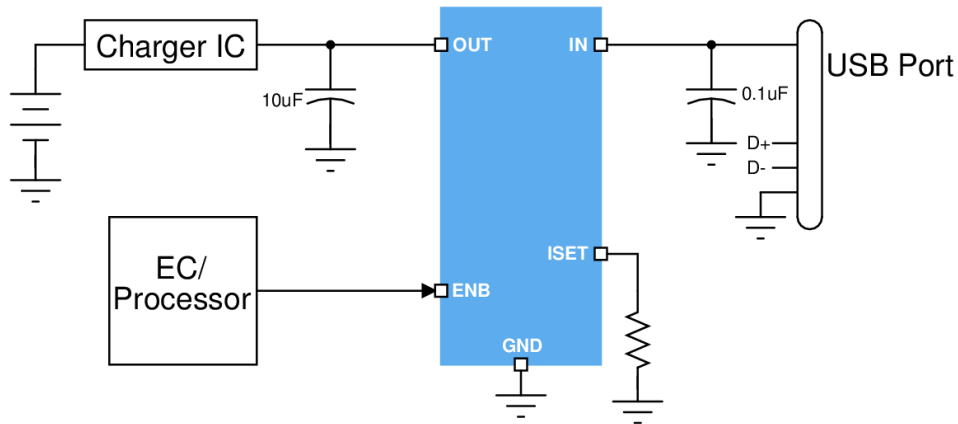
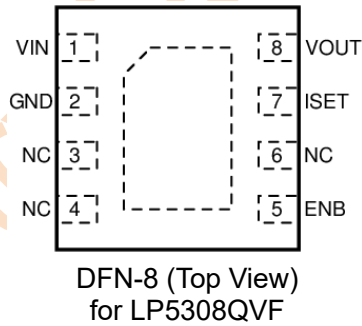
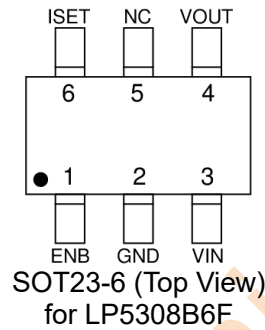

Figure 1. Typical Application Circuitry

Pin Configuration



Pin Description

Pin	Description
GND	Ground
VIN	Power supply and input of power switch
VOUT	Output of power switch
ISET	Over-current protection setting pin, connect a resistor to ground
ENB	Active-low device enable pin



Functional Block Diagram

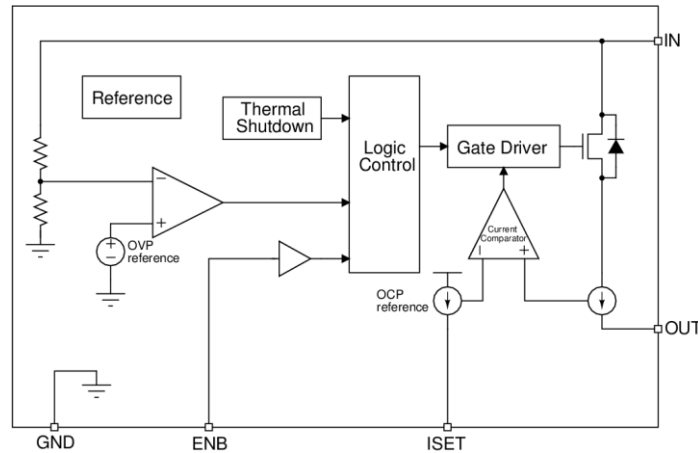

Figure 2. Internal Block Diagram (LP5308)

Absolute Maximum Ratings (Note 1)

- VIN to GND ----- -0.3V to 36V
- VOUT to GND ----- -0.3V to 7V
- ENB to GND ----- -0.3V to 7V
- ISET to GND ----- -0.3V to 7V
- Maximum Junction Temperature (T_A) ----- 150°C
- Maximum Soldering Temperature (at leads, 10 seconds) ----- 260°C

Note 1: Stresses beyond those listed under “Absolute Maximum Ratings” may cause permanent damage to the device. These are stress ratings only, instead of functional operation of the device at these or any other conditions beyond those indicated in the operational sections of the specifications. Exposure to absolute maximum rating conditions for extended periods may affect device reliability.

Thermal Information

- Maximum Power Dissipation (SOT23-6, P_D, T_A ≤ 25°C) ----- 0.6W
- Maximum Power Dissipation (DFN-8, P_D, T_A ≤ 25°C) ----- 1.25W
- Thermal Resistance (SOT23-6, θ_{J-A}) (Note 2) ----- 203°C/W
- Thermal Resistance (DFN-8, θ_{J-A}) (Note 2) ----- 95°C/W

Note 2: It is based on 2S2P JEDEC standard PCB.

ESD Ratings

- HBM (Human Body Model, JEDEC JS-001) ----- ±4000V
- CDM (Charged Device Model, JEDEC JS-002) ----- ±500V

Recommended Operating Conditions

- Input Voltage ----- 3.0V to 5.5V
- Enable Voltage ----- 0V to 6V
- Over-current protection setting value ----- 0.2A to 2.5A
- Ambient Temperature ----- -40°C to 85°C



Electrical Characteristics

The following parameters are guaranteed under condition $V_{IN} = 5V$, $T_A = -40^{\circ}C$ to $85^{\circ}C$ unless otherwise noted, $T_A = 25^{\circ}C$ for typical value.

Parameters	Symbol	Test conditions	Min	Typ	Max	Unit
On-resistance	$R_{DS(ON)}$	$V_{IN} = 5V$, $I_{OUT} = 200mA$, $T_A = 25^{\circ}C$		135	165	m Ω
Input quiescent current	I_Q	$V_{IN} = 5V$, OUT floating, $V_{ENB} = 0V$		90	150	μA
Input shutdown current	I_{SD}	$V_{IN} = 5V$, OUT grounded, $V_{ENB} = 5V$		1		μA
Under-Voltage Lockout level	V_{UVLO_F}	V_{IN} voltage falling	2.6	2.7	2.8	V
	V_{UVLO_R}	V_{IN} voltage rising	2.7	2.8	2.9	V
Over-Voltage Protection level	V_{OVP_F}	V_{IN} voltage falling	5.60	5.75	5.90	V
	V_{OVP_R}	V_{IN} voltage rising	5.70	5.85	6.00	V
Over current protection level	I_{OCP}	$V_{IN} = 5V$, $T_A = 25^{\circ}C$, ISET floating		2.53		A
		$V_{IN} = 5V$, $T_A = 25^{\circ}C$, RSET = 100k Ω		0.25		
		$V_{IN} = 5V$, $T_A = 25^{\circ}C$, RSET = 47k Ω		0.53		
		$V_{IN} = 5V$, $T_A = 25^{\circ}C$, RSET = 25k Ω		1.0		
OCP accuracy	ACC_{OCP}	$V_{IN} = 5V$, $T_A = 25^{\circ}C$, $I_{OCP} > 150mA$		15		%
		$V_{IN} = 5V$, $T_A = 25^{\circ}C$, $I_{OCP} < 150mA$		25		
Over-Voltage Protection response time	t_{OVP}	V_{IN} rising from 5V with 30V/ μs , $R_{OUT} = 100\Omega$, $C_{OUT} = 0$, time from $V_{IN} > V_{OVP_R}$ to OUT voltage stop rising		30	50	ns
Short circuit protection level	I_{SHORT}	$V_{IN} = 5V$, $T_A = 25^{\circ}C$		5		A
Output auto discharge	R_{DIS}	$V_{IN} = 5V$, $V_{EN} = 0V$		3		k Ω
Enable logic high voltage level	V_{IH}	$V_{IN} = 2.4V$ to 6V	1.4			V
Enable logic high voltage level	V_{IL}	$V_{IN} = 2.4V$ to 6V			0.4	V
OCP qualification time	t_{OCP_QUAL}	$V_{IN} = 5V$, $T_A = 25^{\circ}C$, qualification time from I_{OUT} hits I_{OCP} to switch turned off		150		μs
Load switch turned on delay	t_{DON}	$V_{IN} = 5V$, $R_{OUT} = 100\Omega$, $C_{OUT} = 22\mu F$, time from enabled to $V_{OUT} = 0.5$		10		ms
Output rising time	t_R	$V_{IN} = 5V$, $R_{OUT} = 100\Omega$, $C_{OUT} = 22\mu F$, time from $V_{OUT} = 0.1 \times V_{IN}$ to $0.9 \times V_{IN}$		450		μs
Load switch turned off delay	t_{OFF}	$V_{IN} = 5V$, $R_{OUT} = 500\Omega$, $C_{OUT} = 0.1\mu F$, time from disabled to $V_{OUT} = 0.9 \times V_{IN}$		10		μs
Thermal shutdown trigger	T_{SD}	Temperature rising		150		$^{\circ}C$
Thermal shutdown release	T_{SD_REL}	Temperature falling		130		$^{\circ}C$

Note 3. The parameter is guaranteed by design and characterization.



Typical Timing Diagram

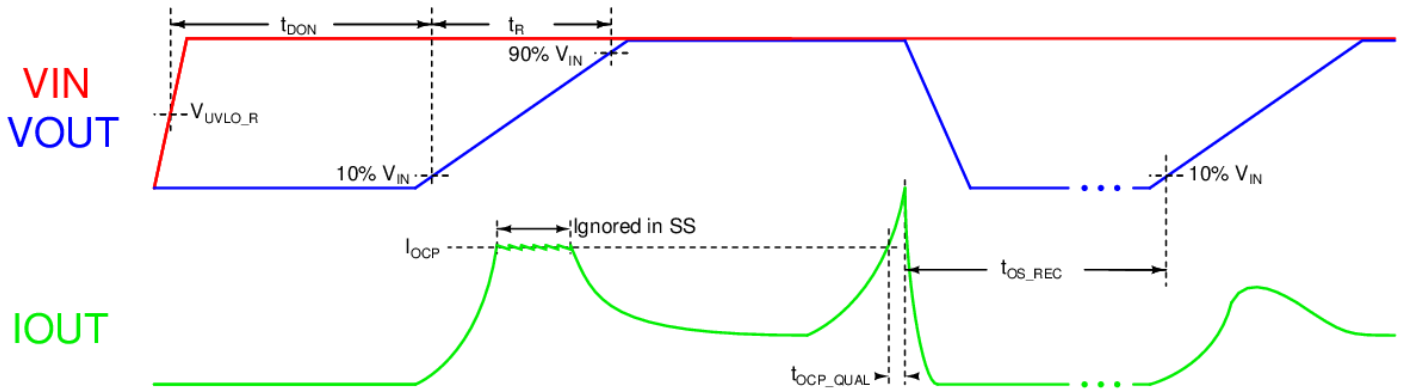

Figure 3. Start-up and over current protection

Typical Performance Characteristics

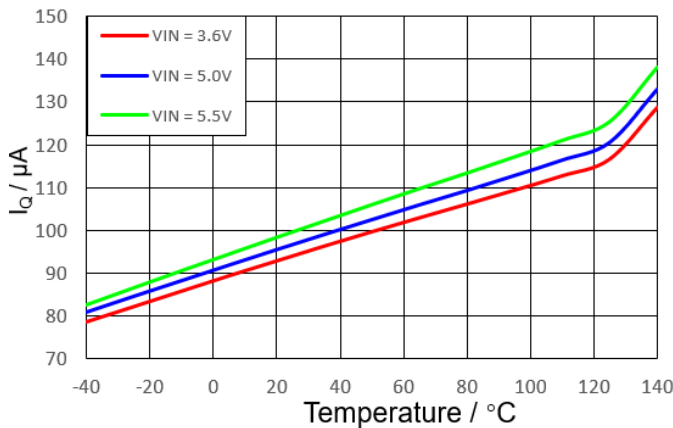

Figure 4. Quiescent Current vs Temperature and V_{IN} (C_{IN}=C_{OUT}=1μF, V_{ENB} = 0V, no load)

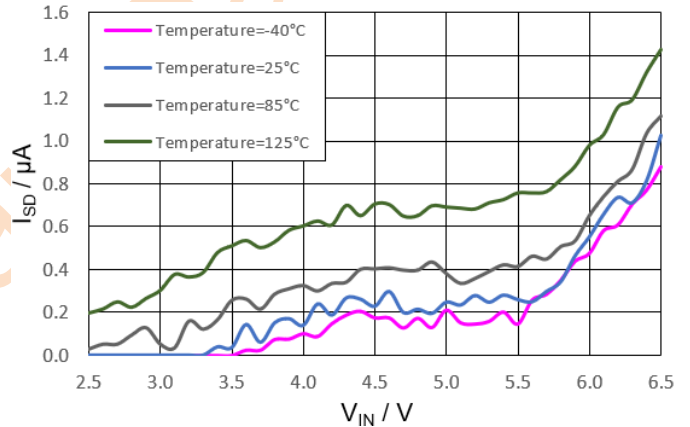

Figure 5. Shutdown Current vs V_{IN} and Temperature (C_{IN}=C_{OUT}=1μF, V_{ENB} = 5V, no load)

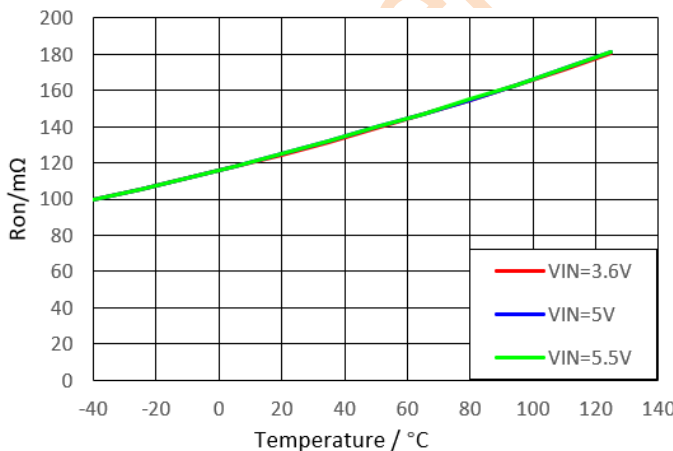

Figure 6. On-resistance vs Temperature (V_{ENB} = 0V, I_{LOAD} = 100mA)

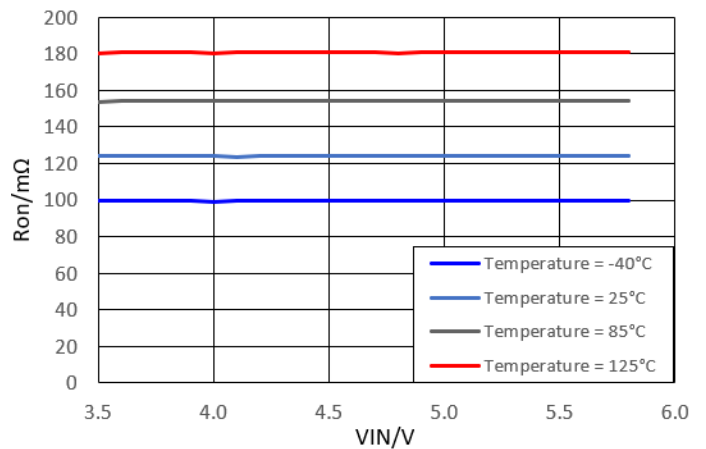

Figure 7. On-resistance vs Input Voltage (V_{ENB} = 0V, I_{LOAD} = 100mA)



Typical Operating Waveforms

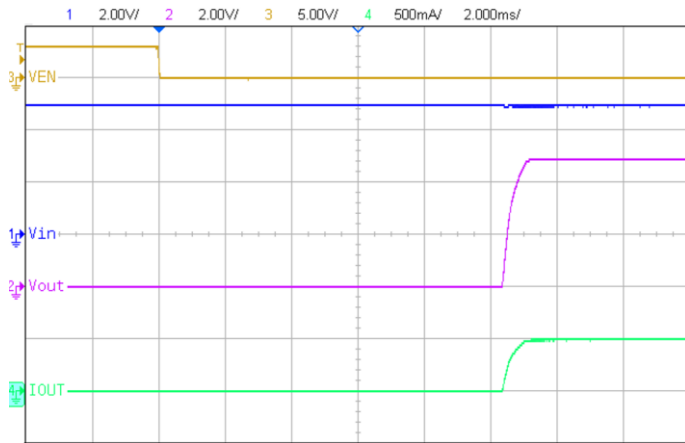

Figure 8. Start-up with enabled by ENB
($V_{IN} = 5V$, $C_{IN} = C_{OUT} = 1\mu F$, $R_{LOAD} = 10\Omega$)

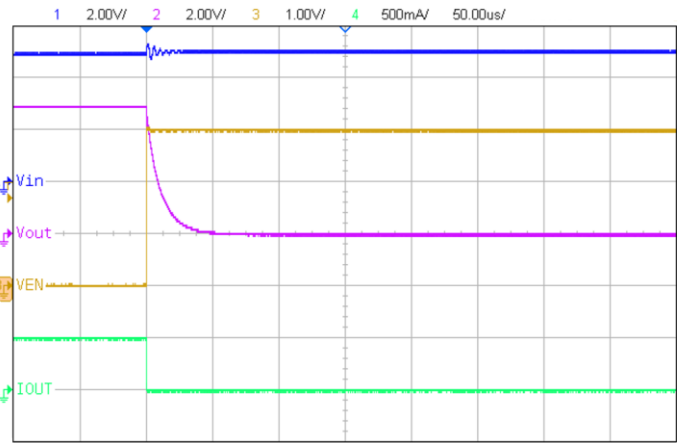

Figure 9. Disabled by ENB
($V_{IN} = 5V$, $C_{IN} = C_{OUT} = 1\mu F$, $R_{LOAD} = 10\Omega$)

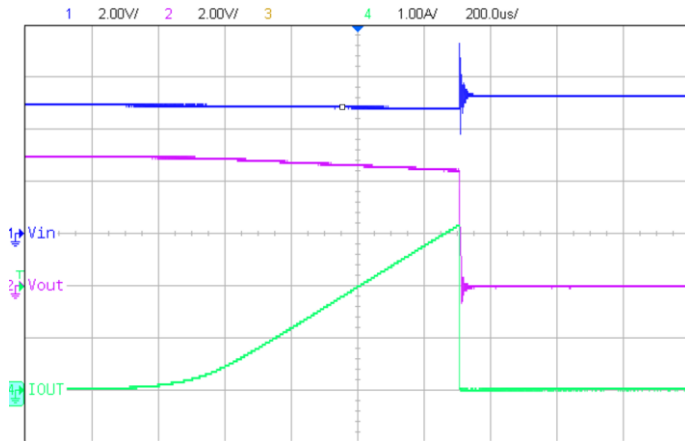

Figure 10. Over-Current Protection Response
(ISET floating, $V_{ENB} = 0V$, 160 μs debounce included)

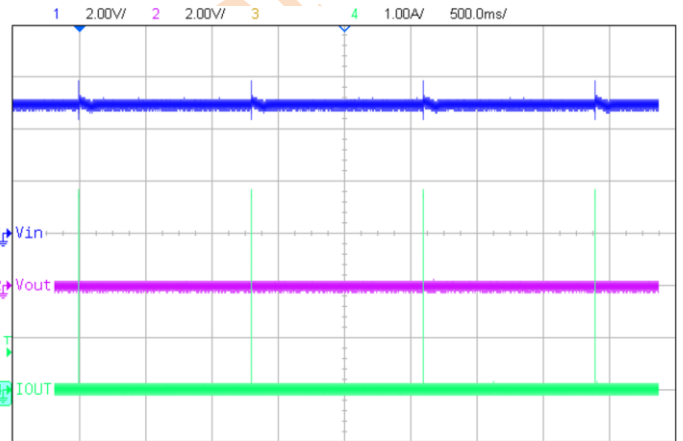

Figure 11. Short-Circuit Protection Response
(ISET floating, $V_{ENB} = 0V$)

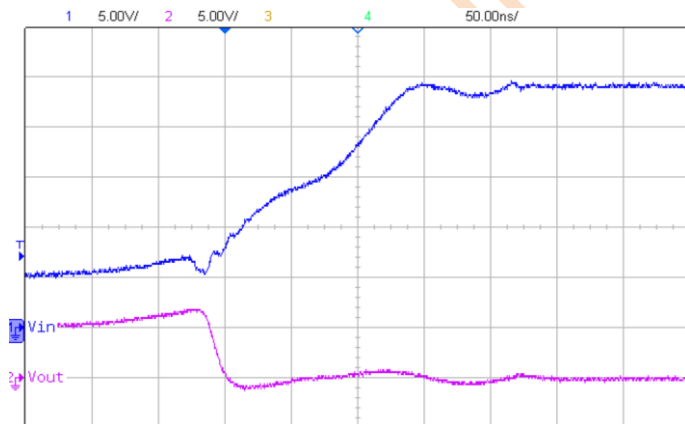

Figure 12. Over-Voltage Protection Response
(V_{IN} normal ramp-up with 4V / 100ns, $R_{LOAD} = 100\Omega$)

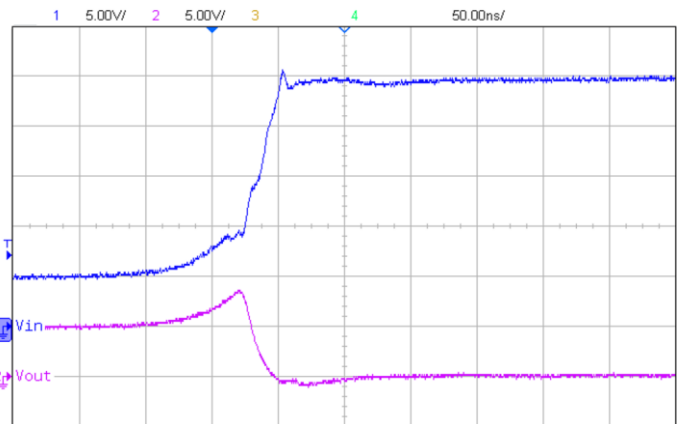

Figure 13. Over-Voltage Protection Response
(V_{IN} fast ramp-up with 25V / 100ns, $R_{LOAD} = 100\Omega$)



Function Description

General Description

LP5308 is a OVP power switch integrated OCP feature to protect systems and loads which can be damaged or disrupted by the application of high currents. The devices all contain a 135mΩ N-channel MOSFET and a controller capable of working over a wide input operating range of 3V to 36V. The controller protects against system malfunctions through over-current protection, under-voltage lockout and thermal shutdown. The OCP is adjustable from 0.2A to 2.5A through an external resistor.

Enable Control

The ENB pin controls the state of the switch. When ENB is pulled low or floating more than 10ms de-bounce time, the load switch is turned on. Activating ENB continuously holds the switch in the on state so long as there is no fault. An under-voltage, over-voltage condition on VIN or a junction temperature in excess of 150°C overrides the ENB control to turn off the switch. The LP5308 does not turn off in response to an over current condition until the current exceed threshold longer than qualification time 150μs, as long as ENB is active and the thermal shutdown or VIN voltage not in proper range.

The enable pin ENB's control voltage and VIN pin have independent recommended operating ranges. The ENB pin voltage can be driven by a voltage level higher than the input voltage. There is internal pull-down resistor on ENB pin. Leave the pin floating will active the device as well.

Over-Current Protection

The OCP feature ensures that the device will disconnect output from input when current through the switch exceed a setting value. The current at which the parts will limit is adjustable through the selection of an external resistor connected to ISET. Once the switch is turned off, unless by disabled through ENB pin, it will not conduct again until 1.3s later. The hiccup behavior will continue as long as the heavy loading condition exist.

Over-Voltage Protection

The LP5308 has Over-Voltage protection to prevent high voltage on VIN passing through to VOUT. Once the voltage on input exceeds the OVP threshold, the power FET will be turned off immediately. When VIN drop back below OVP release level, the switch will be turned on again after a 10ms de-bounce time.

Under-Voltage Lockout

The under-voltage lockout turns-off the switch if the input voltage drops below the under-voltage lockout threshold. With the ENB pin active, the input voltage rising above the under-voltage lockout threshold more than 10ms will cause a controlled turn-on of the switch which limits current over-shoots.

Thermal Shutdown

The thermal shutdown protects the device from internally or externally generated excessive temperatures. During an over temperature condition, the switch is turned off. The switch automatically turns on again if the temperature drops below the threshold temperature more than 1.3s.



Application Information

The LP5308 OCP is set with an external resistor connected between ISET pin and GND. This resistor is selected using the following equation:

$$R_{SET} = \frac{25K}{I_{OCP}} \quad (1)$$

Where, R_{SET} , united as $k\Omega$, is the resistor connected to ISET. I_{OCP} is the expected current limit value in mA. Resistor tolerance of 1% or less is recommended.

The relationship between R_{SET} and I_{OCP} could also be found as below diagram:

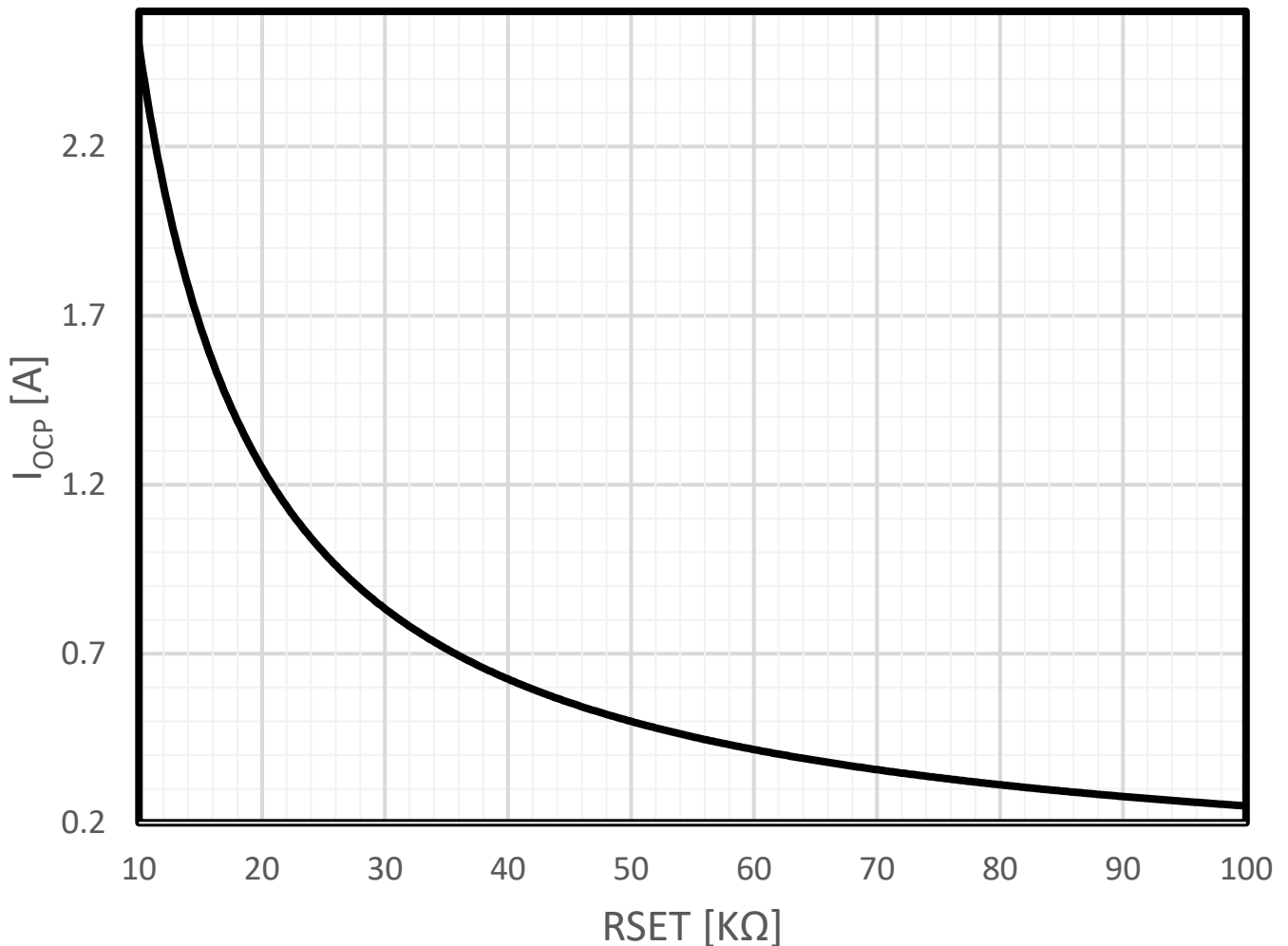
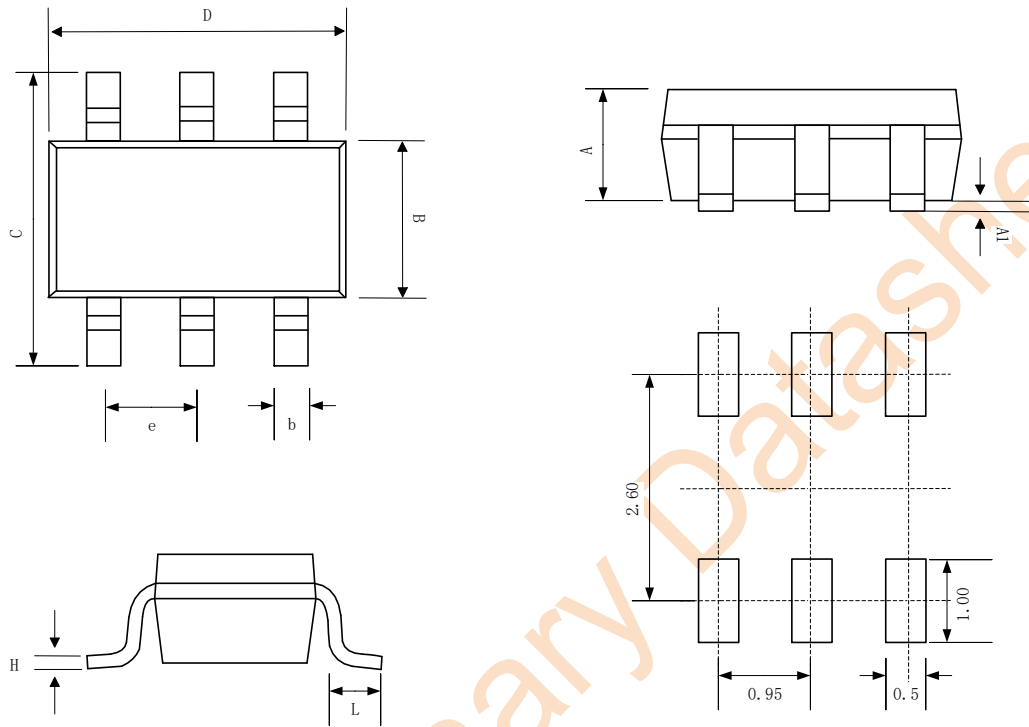

Figure 4. OCP trigger level vs resistor on ISET pin



Package Information

SOT23-6



Recommended Land Pattern

SYMBOL	MILLIMETER		
	MIN	NOM	MAX
A	0.889	1.100	1.295
A1	0.000	0.050	0.152
B	1.397	1.600	1.803
b	0.28	0.35	0.559
C	2.591	2.800	3.000
D	2.692	2.920	3.120
e	0.95BSC		
H	0.080	0.152	0.254
L	0.300	0.450	0.610



DFN-8

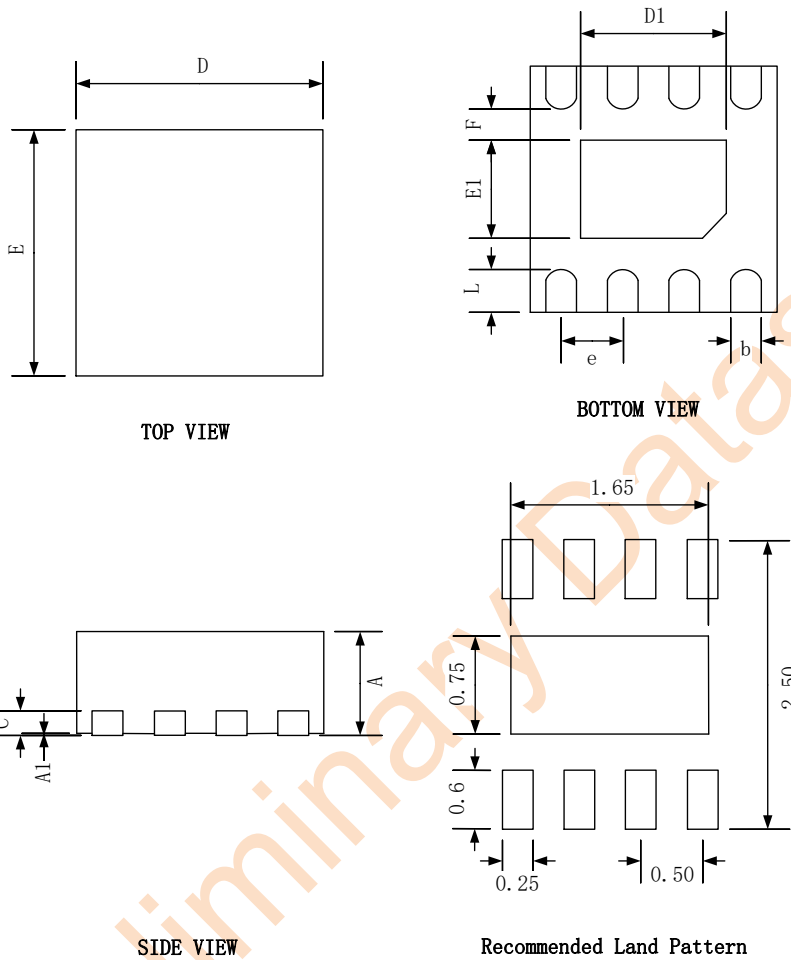

SYMBOL	Dimensions In Millimeters		
	MIN	NOM	MAX
A	0.70	0.75	0.80
A1	0.00	0.02	0.05
b	0.18	0.25	0.30
c	0.20 REF		
D	1.90	2.00	2.10
D1	1.10	1.30	1.65
E	1.90	2.00	2.10
E1	0.60	0.75	0.85
e	0.50 BSC		
L	0.25	0.35	0.40
F	0.25	0.30	0.35

X-ON Electronics

Largest Supplier of Electrical and Electronic Components

Click to view similar products for [Power Switch ICs - Power Distribution](#) category:

Click to view products by [LOWPOWER](#) manufacturer:

Other Similar products are found below :

[TLE6232GP](#) [NCP45520IMNTWG-L](#) [FPF1018](#) [DS1222](#) [NCV380HMUAJAATBG](#) [TCK2065G,LF](#) [SZNCP3712ASNT3G](#)
[NCP45520IMNTWG-H](#) [VND5004ATR-E](#) [ITS5215LXT](#) [AP22811BW5-7](#) [SLG5NT1437VTR](#) [SZNCP3712ASNT1G](#) [DML1008LDS-7](#)
[KTS1640QGDV-TR](#) [KTS1641QGDV-TR](#) [NCV459MNWTBG](#) [NCP4545IMNTWG-L](#) [FPF2260ATMX](#) [SLG5NT1765V](#) [SLG5NT1757V](#)
[NCP45780IMN24RTWG](#) [AP2151AMP-13](#) [NCP45540IMNTWG-L](#) [TPS2022P](#) [FPF2495BUCX](#) [NCP45650IMNTWG](#) [NCV8412ADDR2G](#)
[DK5V100R20S](#) [JW7111SSOTB#TRPBF](#) [RY2121](#) [TPNTGD1100LT1G](#) [TPS27081ADDCR-TP](#) [FDC6331L-TP](#) [FDC6329L-TP](#) [FDC6323L-](#)
[TP](#) [SI3865DDV](#) [TPS2116DRLR](#) [U3213](#) [BTS7020-2EPA](#) [BTT6100-2ERA](#) [BTS71220-4ESA](#) [RS2588CYF5](#) [RS2580XTDE8](#) [LP5308B6F](#)
[ME1502AM5G](#) [SGM2576YN5G/TR](#) [DK5V100R15M](#) [SY6287CDEC](#) [BSP75N](#)