



High Efficiency 3A Boost DC/DC Converter

General Description

The LP6216 is a current mode boost DC-DC converter. Its PWM circuitry with built-in 3A current power MOSFET makes this converter highly power efficiently. The LP6216 implements a constant frequency 1MHz PWM control scheme. The high frequency PWM operation also saves board space by reducing external component sizes. The LP6216 features automatic shifting to pulse frequency modulation mode at light loads. Highly integration and internal compensation network minimizes as 6 external component counts. Optimized operation frequency can meet the requirement of small LC filters value and low operation current with high efficiency.

The LP6216 includes under-voltage lockout, current limiting, and thermal overload protection to prevent damage in the event of an output overload. The LP6216 is available in a small 6-pin SOT23-6 package.

Order Information

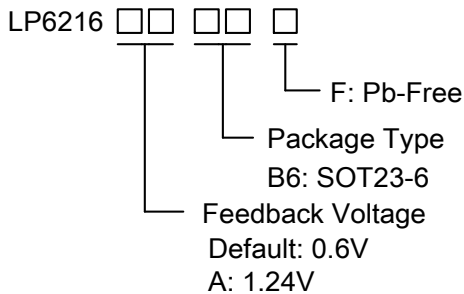

Applications

- ✧ Battery products
- ✧ Host Products
- ✧ Panel

Features

- ◆ Up to 94% efficiency
- ◆ Shut-down current:1uA
- ◆ Input and Output voltage Up to 24V
- ◆ Internal Compensation, Soft-start
- ◆ 1MHz fixed frequency switching
- ◆ High switch on current:3A
- ◆ Available in SOT23-6 Package

Typical Application Circuit

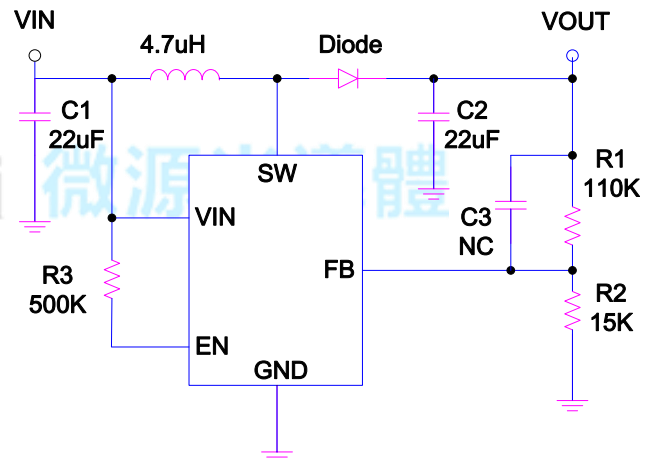

Marking Information

Device	Marking	Package	Shipping
LP6216B6F	LPS 5EYWX	SOT23-6	3K/REEL
Marking indication: Y:Production year W:Production period X:Production batch			



Functional Pin Description

Package Type		Pin Configurations
SOT23-6		<p>The diagram shows a rectangular chip labeled 'LP6216' with a small circle on the left side. Six pins are shown around the chip: pin 1 at the bottom left, pin 2 at the bottom center, pin 3 at the bottom right, pin 4 at the top right, pin 5 at the top center, and pin 6 at the top left.</p>
Pin	Name	Description
1	SW	switching pin.
2	GND	Ground.
3	FB	Regulation Feedback Input. Connect to an external resistive voltage divider from the output to FB to set the output voltage.
4	EN	Regulator ON/OFF Control Input. A logic high input($V_{EN}>1.4V$) turns on the regulator. A logic low input($V_{EN}<0.4V$) puts the LP6216 into low current shutdown mode.
5	VIN	Power Supply pin.
6	NC	No connector.



Function Block Diagram

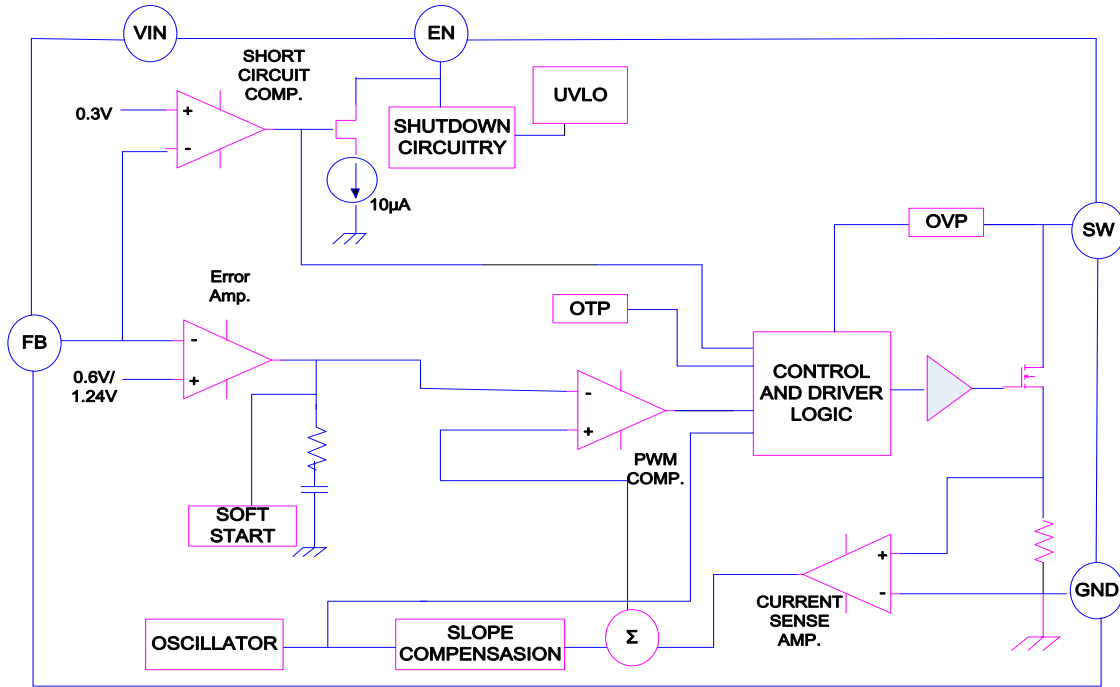

Absolute Maximum Ratings ^{Note 1}

- ✧ VIN to GND ----- 26V
- ✧ SW to GND ----- 30V
- ✧ EN to GND ----- 26V
- ✧ Other Pin Voltage to GND ----- 6V
- ✧ Maximum Junction Temperature ----- 150°C
- ✧ Operating Ambient Temperature Range (T_A) ----- -40°C to 85°C
- ✧ Maximum Soldering Temperature (at leads, 10 sec) ----- 260°C

Note 1. Stresses beyond those listed under “Absolute Maximum Ratings” may cause permanent damage to the device. These are stress ratings only, and functional operation of the device at these or any other conditions beyond those indicated in the operational sections of the specifications is not implied. Exposure to absolute maximum rating conditions for extended periods may affect device reliability.

Thermal Information

- ✧ Maximum Power Dissipation (P_D, T_A=25°C) ----- 0.45W
- ✧ Thermal Resistance (J_A) ----- 250°C/W

ESD Susceptibility

- ✧ HBM(Human Body Mode) ----- 2KV
- ✧ MM(Machine Mode) ----- 200V



Electrical Characteristics

($V_{IN}=3.3V$, $V_{OUT}=5V$, $C_{IN}=22\mu F$, $C_{OUT}=22\mu F$, $L=4.7\mu H$, $R_1=110K$, $R_2=15K$)

Parameter		Condition	Min	Typ	Max	Units
Supply Voltage	V_{IN}		2.5		24	V
Output Voltage Range	V_{OUT}		2.5		24	V
Supply Current(Shutdown)	I_{SD}	$V_{EN}=0V$, $V_{SW}=5V$		1		μA
Supply Current	I_Q			0.35		mA
Feedback Voltage	V_{FB}	LP6216B6F	0.588	0.6	0.612	V
		LP6216AB6F	1.215	1.24	1.265	V
Feedback Input Current	I_{FB}	$V_{FB}=1.2V$		50		nA
Switching Frequency	f_{OSC}			1		MHz
Maximum Duty Cycle			85	92	98	%
EN Input Low Voltage	V_{EN-L}				0.4	V
EN Input High Voltage	V_{EN-H}		1.4			V
EN input current	I_{EN}	$V_{EN}=5$		1		μA
Switch MOSFET Current Limit	I_{SW}			3		A
High-side On Resistance	$R_{DS(ON)}$	$V_{OUT}=5V$		150		m Ω



Typical Operating Characteristics

($C_{IN}=22\mu F, C_{OUT}=22\mu F, L=4.7\mu H, T_A=25^\circ C$, unless otherwise noted)

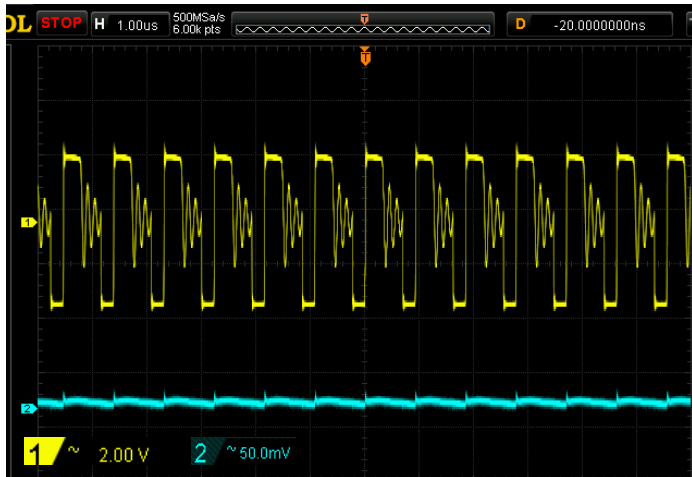
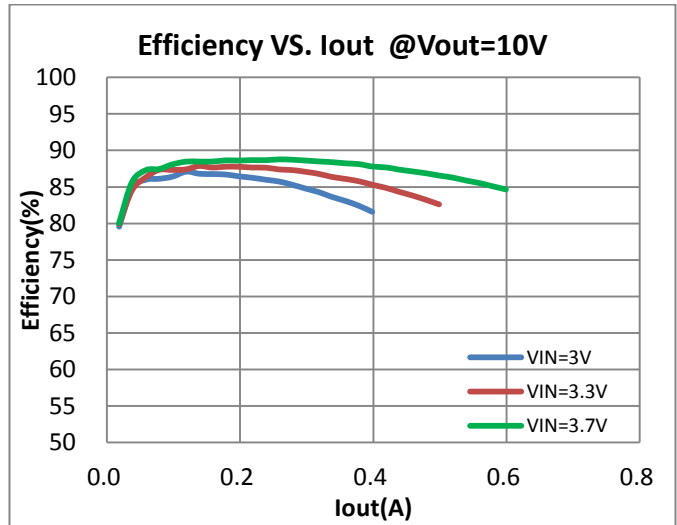
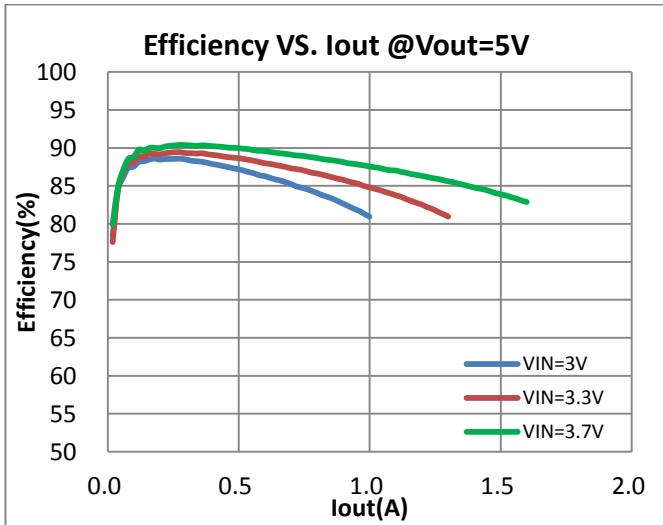

$V_{IN}=3V, V_{OUT}=5V, I_{OUT}=50mA, CH_1=V_{SW}, CH_2=\Delta V_{OUT}$

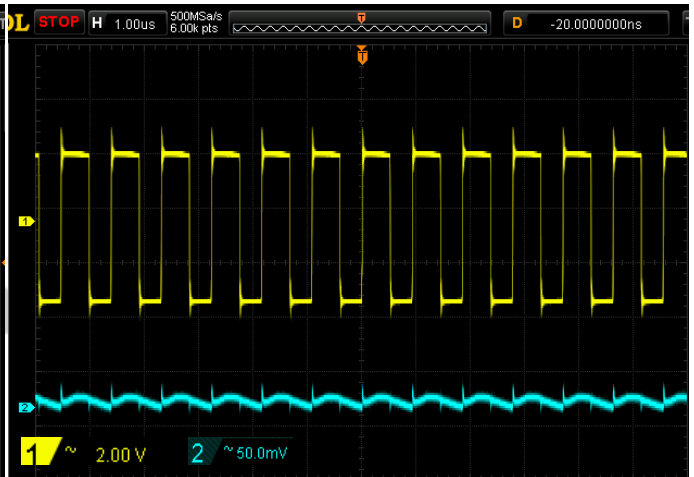

$V_{IN}=3V, V_{OUT}=5V, I_{OUT}=200mA, CH_1=V_{SW}, CH_2=\Delta V_{OUT}$

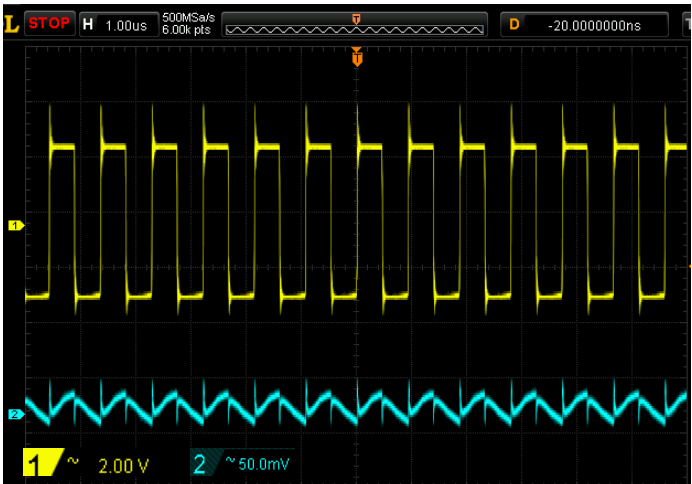

$V_{IN}=3V, V_{OUT}=5V, I_{OUT}=500mA, CH_1=V_{SW}, CH_2=\Delta V_{OUT}$

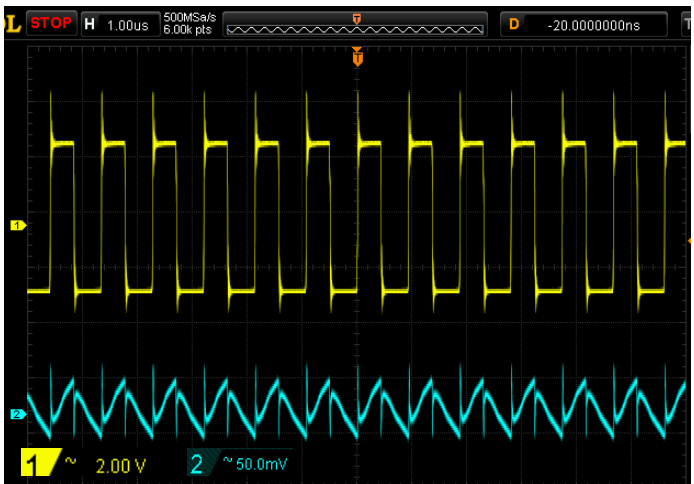

$V_{IN}=3V, V_{OUT}=5V, I_{OUT}=1A, CH_1=V_{SW}, CH_2=\Delta V_{OUT}$



Operation Information

The LP6216 uses a fixed frequency, peak current mode boost regulator architecture to regulate voltage at the feedback pin. At the start of each oscillator cycle the MOSFET is turned on through the control circuitry. To prevent sub-harmonic oscillations at duty cycles greater than 50 percent, a stabilizing ramp is added to the output of the current sense amplifier and the result is fed into the negative input of the PWM comparator. When this voltage equals the output voltage of the error amplifier the power MOSFET is turned off. The voltage at the output of the error amplifier is an amplified version of the difference between the 0.6V bandgap reference voltage and the feedback voltage. In this way the peak current level keeps the output in regulation. If the feedback voltage starts to drop, the output of the error amplifier increases. These results in more current to flow through the power MOSFET, thus increasing the power delivered to the output. The LP6216 has internal soft start to limit the amount of input current at startup and to also limit the amount of overshoot on the output.

Setting the Output Voltage

Set the output voltage by selecting the resistive voltage divider ratio. The voltage divider drops the output voltage to the 0.6V feedback voltage. Use a 100K resistor for R₂ of the voltage divider. Determine the high-side resistor R₁ by the equation:

$$V_{OUT} = (R_1 / R_2 + 1) \times V_{FB}$$

Current Limitation

The internal power-MOS switch current is monitored cycle-by-cycle and is limited to the value not exceed 3A(Typ.). When the switch current reaches the limited value, the internal power-MOS is turned off immediately until the next cycle. Keep traces at this pin as short as possible. Do not put capacitance at this pin.

Inductor Selection

For a better efficiency in high switching frequency converter, the inductor selection has to use a proper core material such as ferrite core to reduce the core loss and choose low ESR wire to reduce copper loss. The most important point is to prevent the core saturated when handling the maximum peak current. Using a shielded inductor can minimize radiated noise in sensitive applications. The maximum peak inductor current is the maximum input current plus the half of inductor ripple current. The calculated peak current has to be smaller than the current limitation in the electrical characteristics. A typical setting of the inductor ripple current is 20% to 40% of the maximum input current. If the selection is 40%, the maximum peak inductor current is

$$\begin{aligned} I_{PEAK} &= I_{IN(MAX)} + \frac{1}{2} I_{RIPPLE} = 1.2 \times I_{IN(MAX)} \\ &= 1.2 \times \left[\frac{I_{OUT(MAX)} \times V_{OUT}}{\eta \times V_{IN(MIN)}} \right] \end{aligned}$$

The minimum inductance value is derived from the following equation:

$$L = \frac{\eta \times V_{IN(MIN)}^2 \times [V_{OUT} - V_{IN(MIN)}]}{0.4 \times I_{OUT(MAX)} \times V_{OUT}^2 \times f_{OSC}}$$

Depending on the application, the recommended inductor value is between 2.2μH to 10μH.



Diode Selection

To achieve high efficiency, Schottky diode is good choice for low forward drop voltage and fast switching time. The output diode rating should be able to handle the maximum output voltage, average power dissipation and the pulsating diode peak current.

Input Capacitor Selection

For better input bypassing, low-ESR ceramic capacitors are recommended for performance. A 22 μ F input capacitor is sufficient for most applications. For a lower output power requirement application, this value can be decreased.

Output Capacitor Selection

For lower output voltage ripple, low-ESR ceramic capacitors are recommended. The tantalum capacitors can be used as well, but the ESR is bigger than ceramic capacitor. The output voltage ripple consists of two components: one is the pulsating output ripple current flows through the ESR, and the other is the capacitive ripple caused by charging and discharging.

$$\begin{aligned} V_{\text{RIPPLE}} &= V_{\text{RIPPLE_ESR}} + V_{\text{RIPPLE_C}} \\ &\cong I_{\text{PEAK}} \times R_{\text{ESR}} + \frac{I_{\text{PEAK}}}{C_{\text{OUT}}} \left(\frac{V_{\text{OUT}} - V_{\text{IN}}}{V_{\text{OUT}} \times f_{\text{OSC}}} \right) \end{aligned}$$

Layout Guideline

For high frequency switching power supplies, the PCB layout is important step in system application design. In order to let IC achieve good regulation, high efficiency and stability, it is strongly recommended the power components should be placed as close as possible. The set traces should be wide and short. The feedback pin and then works of feedback and compensation should keep away from the power loops, and be shielded with a ground trace or plane to prevent noise coupling. Input and Output capacitors should be placed close to the IC and connected to ground plane to reduce noise coupling.





Packaging Information

SOT23-6

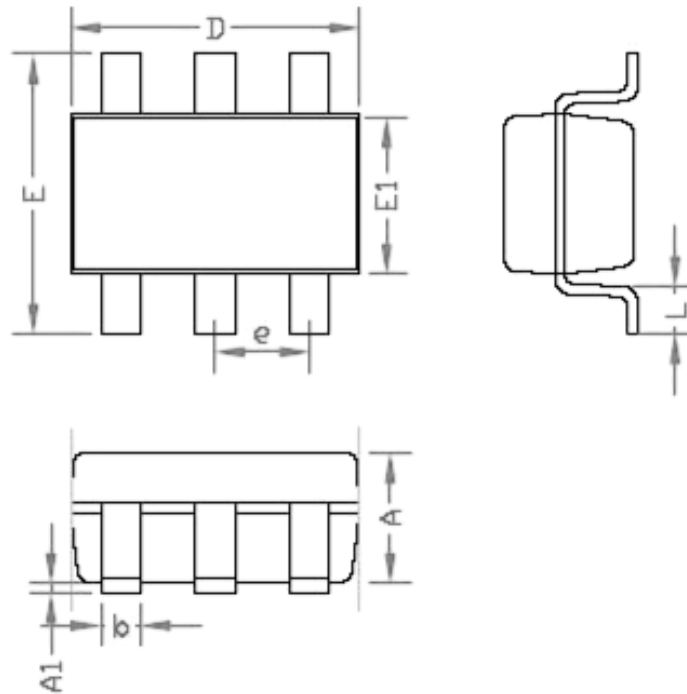

SYMBOLS	MILLIMETERS		INCHES	
	MIN.	MAX.	MIN.	MAX.
A	-	1.45	-	0.057
A1	0.00	0.15	0.000	0.006
b	0.30	0.50	0.012	0.020
D	2.90		0.114	
E1	1.60		0.063	
e	0.95		0.037	
E	2.60	3.00	0.102	0.118
L	0.3	0.60	0.012	0.024

X-ON Electronics

Largest Supplier of Electrical and Electronic Components

Click to view similar products for [Isolated DC/DC Converters](#) category:

Click to view products by [LOWPOWER](#) manufacturer:

Other Similar products are found below :

[ESM6D044440C05AAQ](#) [FMD15.24G](#) [PSL486-7LR](#) [PSR152.5-7IR](#) [Q48T30020-NBB0](#) [AVO240-48S12B-6L](#) [AVO250-48S28B-6L](#) [NAN-0505](#) [HW-L16D](#) [JAHW100Y1](#) [217-1617-001](#) [22827](#) [SPB05C-12](#) [SQ24S15033-PS0S](#) [18952](#) [19-130041](#) [CE-1003](#) [CE-1004](#) [GQ2541-7R](#) [PSE1000DCDC-12V](#) [RDS180245](#) [MAU228](#) [419-2065-201](#) [449-2075-101](#) [J80-0041NL](#) [V300C24C150BG](#) [419-2062-200](#) [419-2063-401](#) [419-2067-101](#) [419-2067-501](#) [419-2068-001](#) [DCG40-5G](#) [DFC15U48D15](#) [449-2067-000](#) [XGS-0512](#) [XGS-1205](#) [XGS-1212](#) [XGS-2412](#) [XGS-2415](#) [XKS-1215](#) [033456](#) [NCT1000N040R050B](#) [SPB05B-15](#) [SPB05C-15](#) [SSQE48T25025-NAA0G](#) [L-DA20](#) [HP3040-9RG](#) [HP1001-9RTG](#) [XKS-2415](#) [XKS-2412](#)