



## High Efficiency 2.4A Boost DC/DC Converter

### General Description

The LP6230B is a current mode boost DC-DC converter. Its PWM circuitry with built-in 0.16Ω, 2.4A current power MOSFET makes this converter highly power efficiently. The LP6230B implements a constant frequency 1MHz PWM control scheme. The high frequency PWM operation also saves board space by reducing external component sizes. The LP6230B features automatic shifting to pulse frequency modulation mode at light loads. Highly integration and internal compensation network minimizes as 6 external component counts. Optimized operation frequency can meet the requirement of small LC filters value and low operation current with high efficiency.

The LP6230B includes under-voltage lockout, current limiting, and thermal overload protection to prevent damage in the event of an output overload. The LP6230B is available in a small 8-pin MSOP8 package.

### Order Information

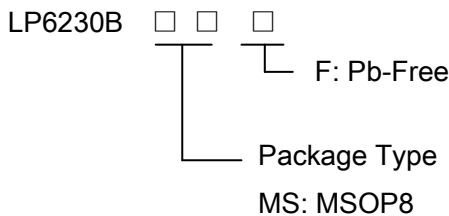

### Applications

- ✧ Battery products
- ✧ Host Products
- ✧ Panel

### Features

- ◆ Up to 94% efficiency
- ◆ Shut-down current:<1uA
- ◆ Output voltage Up to 18V
- ◆ Internal Compensation
- ◆ 1MHz fixed frequency switching
- ◆ High switch on current:2.4A
- ◆ Available in MSOP8 Package

### Typical Application Circuit

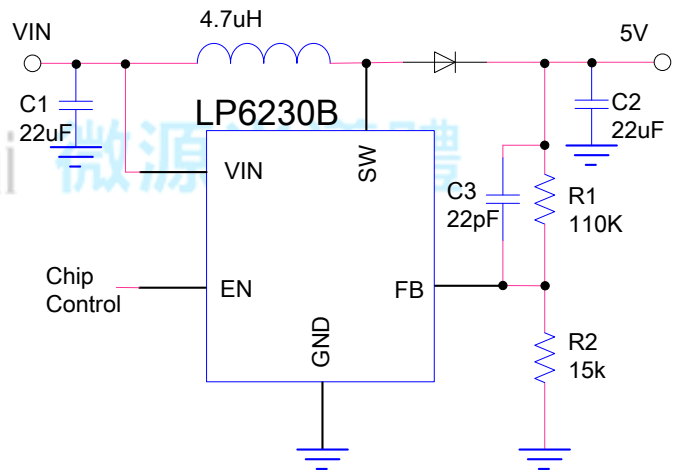

### Marking Information

Device	Marking	Package	Shipping
LP6230B		MSOP8	3K/REEL



### Functional Pin Description

Package Type		Pin Configurations
MSOP8		
Pin	Name	Description
1,7,8	NC	No Connector.
2	FB	Regulation Feedback Input. Connect to an external resistive voltage divider from the output to FB to set the output voltage.
3	EN	Regulator ON/OFF Control Input. A logic high input( $V_{EN}>1.4V$ ) turns on the regulator. A logic low input( $V_{EN}<0.4V$ ) puts the LP6230B into low current shutdown mode.
4	GND	Ground.
5	SW	switching pin.
6	VIN	Power Supply pin.

### Application Circuit

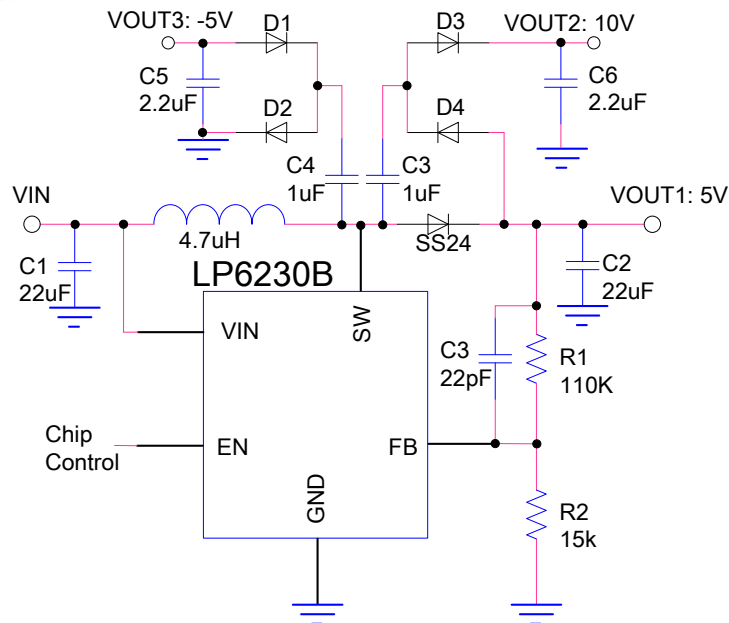

### Function Diagram

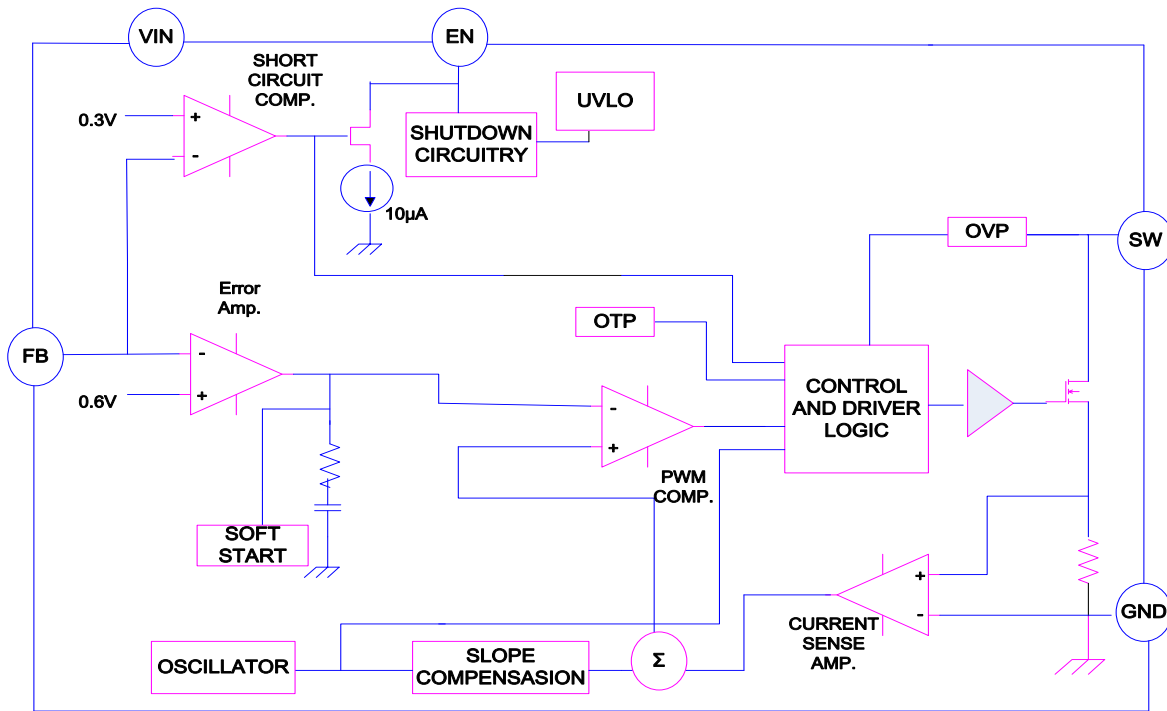

### Absolute Maximum Ratings <sup>Note 1</sup>

- ✧ Input to GND ----- -03V to 8V
- ✧ SW Pin to GND ----- 22V
- ✧ Other Pin to GND ( $V_{FB}, V_{EN}$ ) ----- 6V
- ✧ Operation Junction Temperature Range ----- 150°C
- ✧ Operation Ambient Temperature Range ----- -40°C to 85°C
- ✧ Lead Temperature (Soldering, 10 sec.) ----- 260°C

**Note 1.** Stresses beyond those listed under “Absolute Maximum Ratings” may cause permanent damage to the device. These are stress ratings only, and functional operation of the device at these or any other conditions beyond those indicated in the operational sections of the specifications is not implied. Exposure to absolute maximum rating conditions for extended periods may affect device reliability.

### Thermal Information

- ✧ Maximum Power Dissipation (MSOP8, PD,  $T_A=25^\circ\text{C}$ ) ----- 900mW
- ✧ Thermal Resistance ( $\theta_{JA}$ ) ----- 165°C/W

### Recommended Operating Conditions

- ✧ Supply Input Voltage ----- 2.2V to 6V
- ✧ EN Input Voltage ----- 0V to 5.5V



## Electrical Characteristics

( $V_{IN}=3.3V$ ,  $V_{OUT}=5V$ ,  $C_{IN}=10\mu F$ ,  $C_{OUT}=22\mu F$ ,  $L=4.7\mu H$ ,  $R_1=110K$ ,  $R_2=15K$ )

Parameter	Condition	Min	Typ.	Max	Units
Supply Voltage		2.2		6	V
Output Voltage Range		2.5		18	V
Supply Current(Shutdown)	$V_{EN}=V_{OUT}=0V$ , $V_{SW}=5V$		0.5	1	$\mu A$
Supply Current	$V_{FB}=0.8V$		150		$\mu A$
Feedback Voltage			0.6		V
Feedback Input Current			50		nA
Switching Frequency			1		MHz
Maximum Duty Cycle		85	90		%
EN Input Low Voltage				0.4	V
EN Input High Voltage		1.4			V
Low-side Current Limit			2.4		A
High-side On Resistance	$V_{OUT}=3.3V$		160		m $\Omega$
Mosfet voltage			22		V



### Typical Operating Characteristics

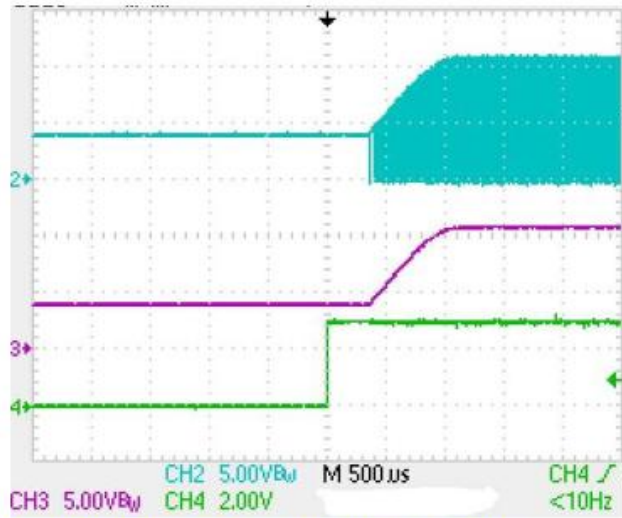

Power On From EN, CH2=LX, CH3=VOUT, CH4=EN

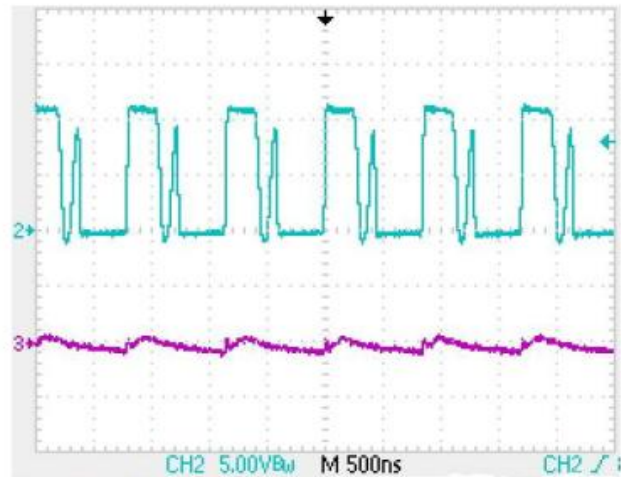

Vout=10V, Vin=3.5V, Iout=50mA, CH2=LX, CH3=VOUT

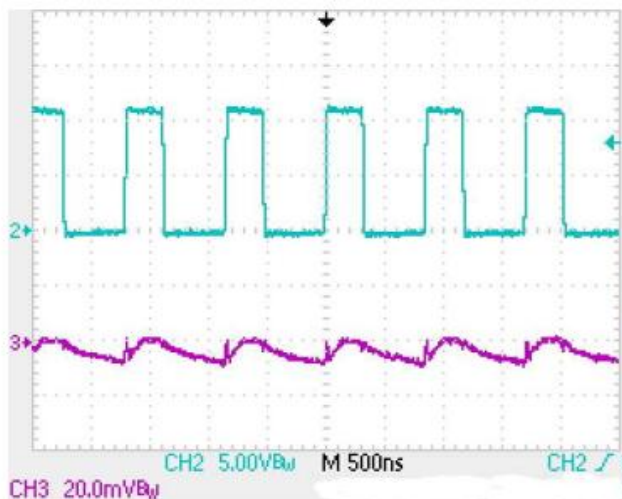

Vout=10V, Vin=3.5V, Iout=100mA, CH2=LX, CH3=VOUT

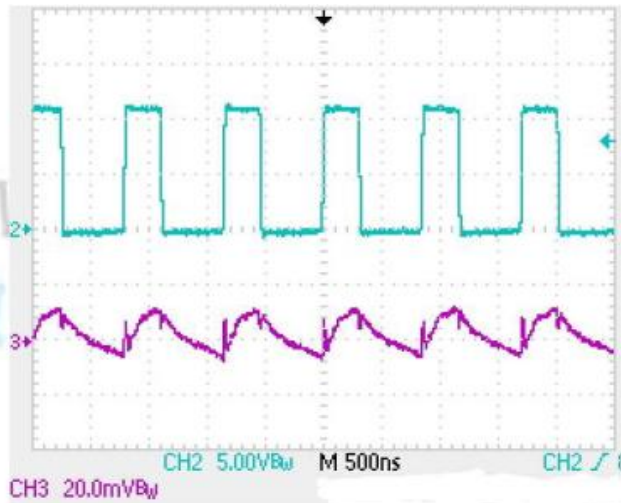

Vout=10V, Vin=3.5V, Iout=200mA, CH2=LX, CH3=VOUT

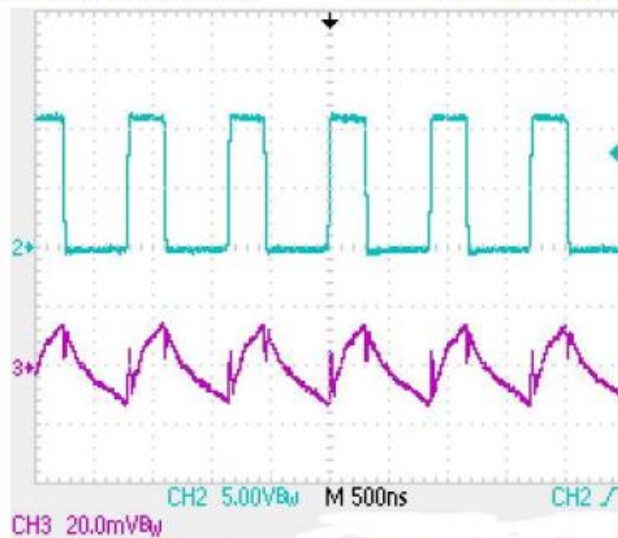

Vout=10V, Vin=3.5V, Iout=300mA, CH2=LX, CH3=VOUT



## Operation Information

The LP6230B uses a fixed frequency, peak current mode boost regulator architecture to regulate voltage at the feedback pin. At the start of each oscillator cycle the MOSFET is turned on through the control circuitry. To prevent sub-harmonic oscillations at duty cycles greater than 50 percent, a stabilizing ramp is added to the output of the current sense amplifier and the result is fed into the negative input of the PWM comparator. When this voltage equals the output voltage of the error amplifier the power MOSFET is turned off. The voltage at the output of the error amplifier is an amplified version of the difference between the 0.6V bandgap reference voltage and the feedback voltage. In this way the peak current level keeps the output in regulation. If the feedback voltage starts to drop, the output of the error amplifier increases. These results in more current to flow through the power MOSFET, thus increasing the power delivered to the output. The LP6230B has internal soft start to limit the amount of input current at startup and to also limit the amount of overshoot on the output.

### Setting the Output Voltage

Set the output voltage by selecting the resistive voltage divider ratio. The voltage divider drops the output voltage to the 0.6V feedback voltage. Use a 100K resistor for  $R_2$  of the voltage divider. Determine the high-side resistor  $R_1$  by the equation:

$$V_{OUT} = ( R_1 / R_2 + 1 ) \times V_{FB}$$

$$V_{OUT} = ( R_1 / R_2 + 1 ) \times 0.6V$$



## Packaging Information

### MSOP-8L

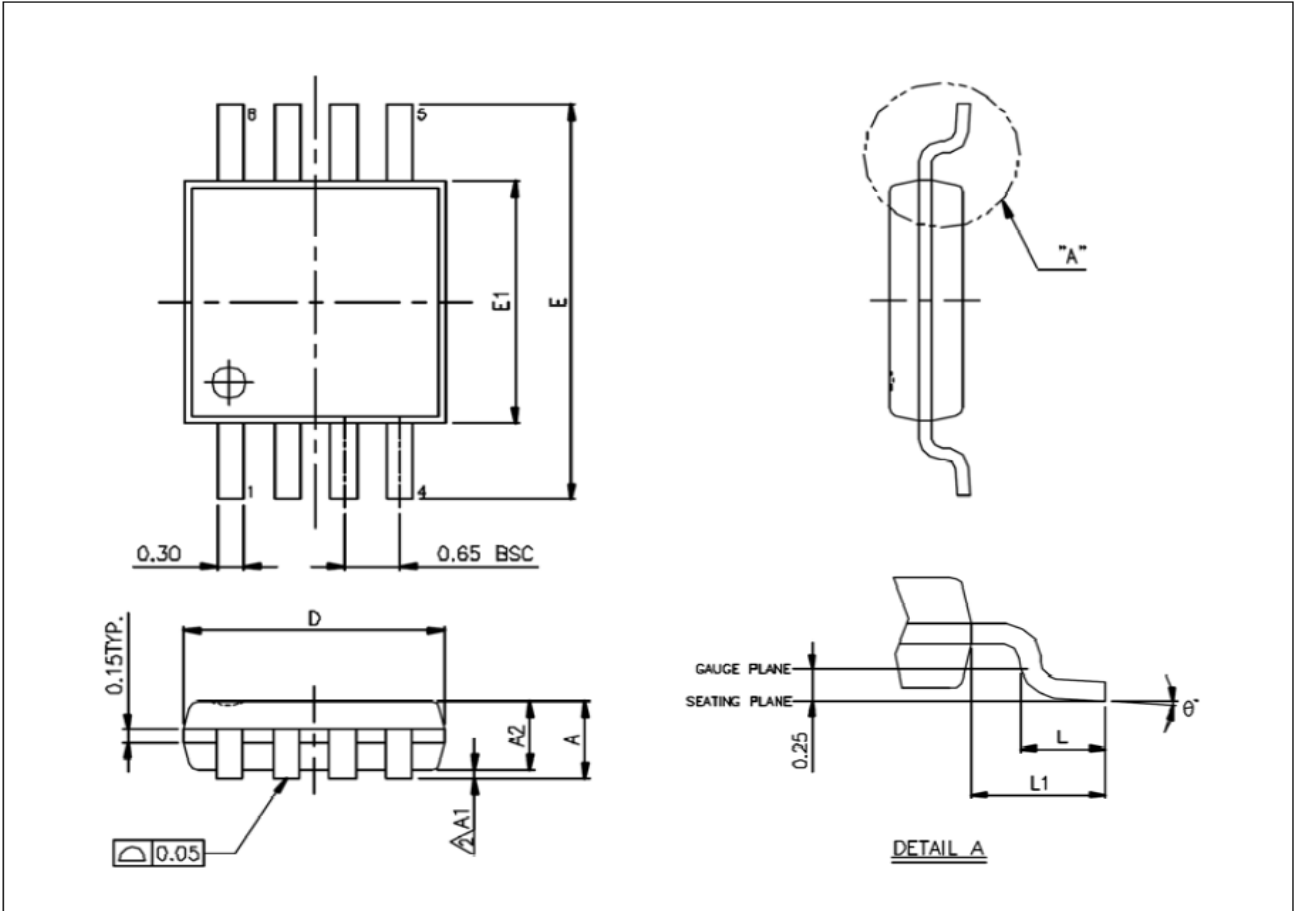

Unit: mm

Symbols	Min. (mm)	Max. (mm)
A		1.100
A1	0.000	0.150
A2	0.750	0.950
D	3.000 BSC	
E	4.900 BSC	
E1	3.000 BSC	
L	0.400	0.800
L1	0.950 REF	
θ°	0°	8°

#### Note:

1. Package dimensions are in compliance with JEDEC outline: MO-187 AA.
2. Dimension "D" does not include molding flash, protrusions or gate burrs.
3. Dimension "E1" does not include inter-lead flash or protrusions.

## X-ON Electronics

Largest Supplier of Electrical and Electronic Components

*Click to view similar products for [Isolated DC/DC Converters](#) category:*

*Click to view products by [LOWPOWER](#) manufacturer:*

Other Similar products are found below :

[ESM6D044440C05AAQ](#) [FMD15.24G](#) [PSL486-7LR](#) [PSR152.5-7IR](#) [Q48T30020-NBB0](#) [AVO240-48S12B-6L](#) [AVO250-48S28B-6L](#) [NAN-0505](#) [HW-L16D](#) [JAHW100Y1](#) [217-1617-001](#) [22827](#) [SPB05C-12](#) [SQ24S15033-PS0S](#) [18952](#) [19-130041](#) [CE-1003](#) [CE-1004](#) [GQ2541-7R](#) [PSE1000DCDC-12V](#) [RDS180245](#) [MAU228](#) [419-2065-201](#) [449-2075-101](#) [J80-0041NL](#) [V300C24C150BG](#) [419-2062-200](#) [419-2063-401](#) [419-2067-101](#) [419-2067-501](#) [419-2068-001](#) [DCG40-5G](#) [DFC15U48D15](#) [449-2067-000](#) [XGS-0512](#) [XGS-1205](#) [XGS-1212](#) [XGS-2412](#) [XGS-2415](#) [XKS-1215](#) [033456](#) [NCT1000N040R050B](#) [SPB05B-15](#) [SPB05C-15](#) [SSQE48T25025-NAA0G](#) [L-DA20](#) [HP3040-9RG](#) [HP1001-9RTG](#) [XKS-2415](#) [XKS-2412](#)