



High Efficiency Boost DC/DC Controller

General Description

The LP6240 is a high performance non-synchronous boost converter controller that drives all N-channel power MOSFETs. Synchronous rectification increases efficiency, reduces power losses and eases thermal requirements, allowing the LP6240 to be used in high power boost applications.

A 4.5V to 24V input supply range encompasses a wide range of system architectures. The LP6240 features operating fixed-frequency at 600kHz and a 1.215V reference voltage. The CS pin can adjustable the current limited and slope compensation by permutations the external resistor .

Other features include over current protection (OCP), output over voltage protection (OVP), and under-voltage lockout (UVLO). The LP6240 is available in a space saving SOP-8 (0.5mm pitch) package.

Order Information

LP6240 □□□
 F: Green
 Package Type
 SO: SOP-8



Features

- ◆ Wide V_{IN} Range: 4.5V to 24V
- ◆ Current-Mode PWM Controller
- ◆ Under-Voltage Lockout
- ◆ Over Voltage Protection
- ◆ Over Current Protection
- ◆ Under-Voltage Protection
- ◆ Over-Temperature Protection
- ◆ Available in SOP-8
- ◆ RoHS Compliant and Halogen Free
- ◆ Pb-Free Package

Applications

- ◆ Battery Products
- ◆ Audio Amplifier

Marking Information

Device	Marking	Package	Shipping
LP6240	LPS	SOP-8	4K/REEL
	LP6240 YWX		

Y: Y is year code. W: W is week code. X: X is series number.



Typical Application Circuit

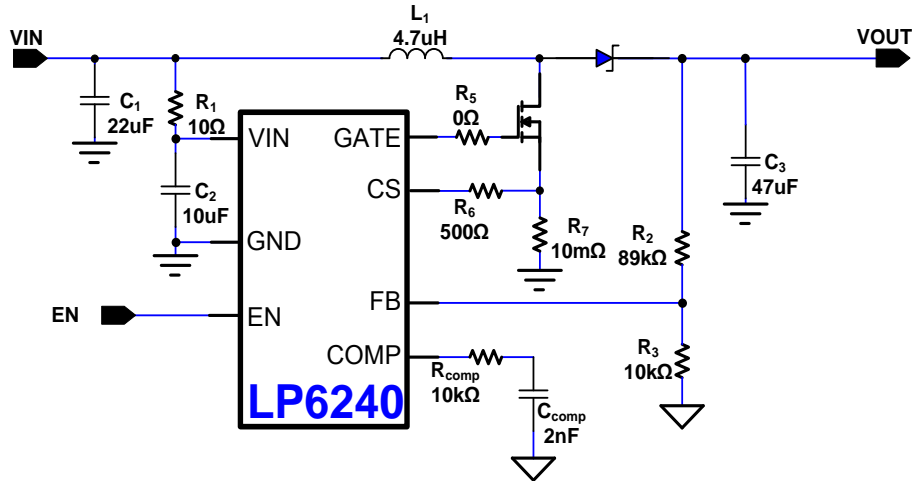

Figure 1. Typical Application Circuit of LP6240

Pin Configuration

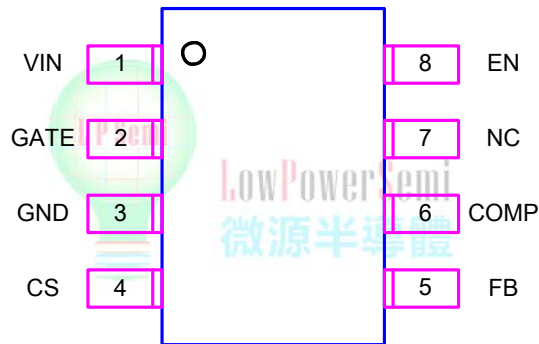

Figure 2. SOP-8 Package Top View



Function Block Diagram

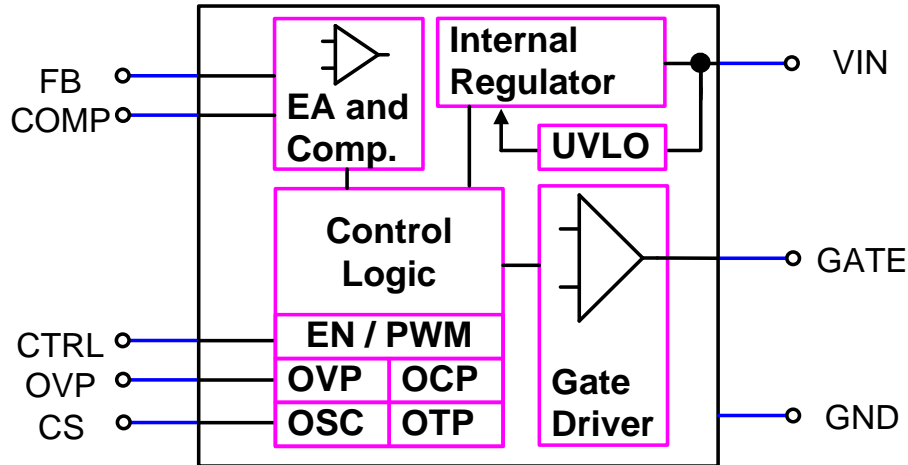

Figure 3. Function Block Diagram

Functional Pin Description

Pin NO.	Pin Name	Description
1	VIN	Input Supply Pin. Decouple with 10 μ F ceramic capacitor close to the pin.
2	GATE	External NMOS Gate Drive Pin.
3	GND	Ground.
4	CS	Current Sense Input Pin.
5	FB	Regulator Feedback Input. Connect to an external resistive to set the output current.
6	COMP	Regulator Error Amplifier Compensation Pin.
7	NC	No Connection.
8	EN	Chip Enable Control.



Absolute Maximum Ratings ^{Note 1}

◇ VIN to GND	-----	-0.3V to +28V
◇ GATE, EN to GND	-----	-0.3V to +28V
◇ CS, FB, COMP to GND	-----	-0.3V to +6.5V
◇ Operating Junction Temperature Range (T _J)	-----	-40°C to +150°C
◇ Operation Ambient Temperature Range	-----	-40°C to +85°C
◇ Storage Temperature Range	-----	-65°C to +150°C
◇ Maximum Soldering Temperature (at leads, 10sec)	-----	+260°C
◇ Maximum Junction Temperature	-----	+150°C

Note 1. Stresses beyond those listed under “Absolute Maximum Ratings” may cause permanent damage to the device. These are stress ratings only, and functional operation of the device at these or any other conditions beyond those indicated in the operational sections of the specifications is not implied. Exposure to absolute maximum rating conditions for extended periods may affect device reliability.

Thermal Information

◇ Thermal Resistance		
SOP-8, θ_{JA}	-----	112°C/W
SOP-8, θ_{JC}	-----	39°C/W





Electrical Characteristics

($V_{IN}=12V$, $V_{EN}=5V$, $T_A=25^{\circ}C$, unless otherwise specified)

Parameter	Symbol	Test Conditions	Min	Typ	Max	Units
General						
Input Supply Voltage	V_{IN}		4.5		24	V
V_{IN} Supply Current	I_Q	Shutdown Current		20	50	μA
		Sleep Current		0.5	1	mA
		Operation Current		2	4	mA
Input UVLO Threshold	$V_{UVLO(VTH)}$	V_{IN} Rising		3.6		V
UVLO Threshold Hysteresis	$V_{UVLO(HYS)}$	Falling Hysteresis		170		mV
Soft Start Time	T_{SS}			15		ms
Thermal Shutdown Threshold	T_{SD}	Temperature Rising		150		$^{\circ}C$
Thermal Shutdown Hysteresis	ΔT_{SD}			25		$^{\circ}C$
EN Function						
EN Threshold Voltage	V_{IH}	Logic High.			1.5	V
	V_{IL}	Logic Low	0.7			
Pull Down Resistor	R_{PULL_LOW}			150		k Ω
Boost Regulator						
Feedback Voltage	V_{FB}		1.191	1.215	1.239	V
Internal Oscillator Frequency	F_{OSC}			600		kHz
Maximum Duty Cycle	D_{MAX}			80		%
Voltage Gain of Error Amplifier	A_V			1500		V/V
Transconductance of EA	G_m			100		$\mu A/V$
Gate Driver Clamp				12		V
Gate rising time		$C_{Gate}=500pF$		40		μA
Gate falling time		$C_{Gate}=500pF$		20		μA
Over Current Protection	V_{OCP}	Threshold of OCP		100		mV
Slope Compensation Current	I_{Slope}			40		μA
Under Voltage Protection	V_{UVP}			1		V
Fault Trigger Duration	T_{Fault}			42		ms
SCP Threshold	V_{SCP}			0.5		V
Hiccup Off Timer				580		ms



Outline Information

SOP-8 Package (Unit: mm)

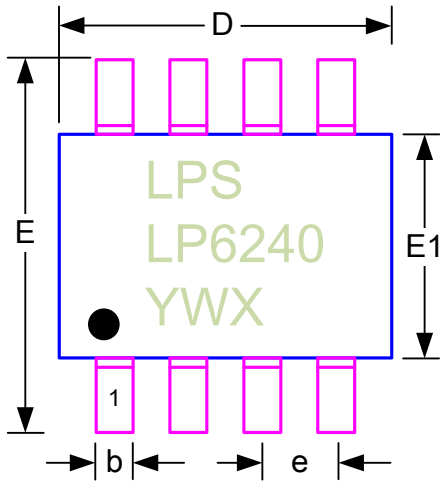

SYMBOLS UNIT	DIMENSION IN MILLIMETER		
	MIN	NOM	MAX
A	--	--	1.750
A1	0.100	--	0.225
A2	1.300	1.400	1.500
A3	0.600	0.650	0.700
b	0.390	--	0.470
D	4.800	4.900	5.000
E	5.800	6.000	6.200
E1	3.800	3.900	4.000
e	1.27BSC		
L	0.500	--	0.800

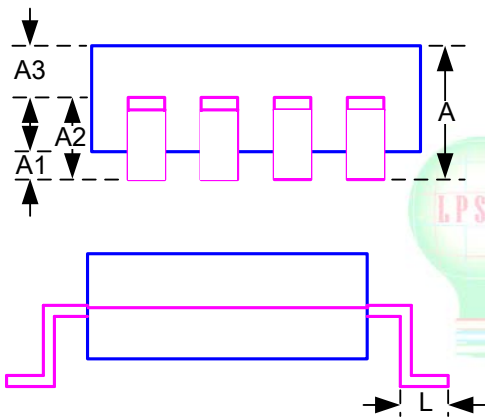

X-ON Electronics

Largest Supplier of Electrical and Electronic Components

Click to view similar products for [Isolated DC/DC Converters](#) category:

Click to view products by [LOWPOWER](#) manufacturer:

Other Similar products are found below :

[ESM6D044440C05AAQ](#) [FMD15.24G](#) [PSL486-7LR](#) [PSR152.5-7IR](#) [Q48T30020-NBB0](#) [AVO240-48S12B-6L](#) [AVO250-48S28B-6L](#) [NAN-0505](#) [HW-L16D](#) [JAHW100Y1](#) [217-1617-001](#) [22827](#) [SPB05C-12](#) [SQ24S15033-PS0S](#) [18952](#) [19-130041](#) [CE-1003](#) [CE-1004](#) [GQ2541-7R](#) [PSE1000DCDC-12V](#) [RDS180245](#) [MAU228](#) [419-2065-201](#) [449-2075-101](#) [J80-0041NL](#) [V300C24C150BG](#) [419-2062-200](#) [419-2063-401](#) [419-2067-101](#) [419-2067-501](#) [419-2068-001](#) [DCG40-5G](#) [DFC15U48D15](#) [449-2067-000](#) [XGS-0512](#) [XGS-1205](#) [XGS-1212](#) [XGS-2412](#) [XGS-2415](#) [XKS-1215](#) [033456](#) [NCT1000N040R050B](#) [SPB05B-15](#) [SPB05C-15](#) [SSQE48T25025-NAA0G](#) [L-DA20](#) [HP3040-9RG](#) [HP1001-9RTG](#) [XKS-2415](#) [XKS-2412](#)