



Wide Range Synchronous Buck Controller

General Description

The LP6496 is a synchronous step down regulator with CC control from a high voltage input supply. Operating with an input voltage 8V~40V, the LP6496 achieves 5A continuous output current with excellent load and line regulation. Current mode operation provides fast transient response and eases loop stabilization.

The LP6496 requires a minimum number of readily available standard external components. Other features include cable compensation, programmable current limit and thermal shutdown.

The LP6496 converters are available in the industry standard SOP8 packages.

Features

- ◆ Wide Input Voltage Range: 8V ~ 40V
- ◆ Up to 94% Efficiency
- ◆ No Loop Compensation Required
- ◆ CC/CV control
- ◆ Programmable CC Current
- ◆ Thermal Shutdown
- ◆ Available in SOP8 Package

Typical Application Circuit

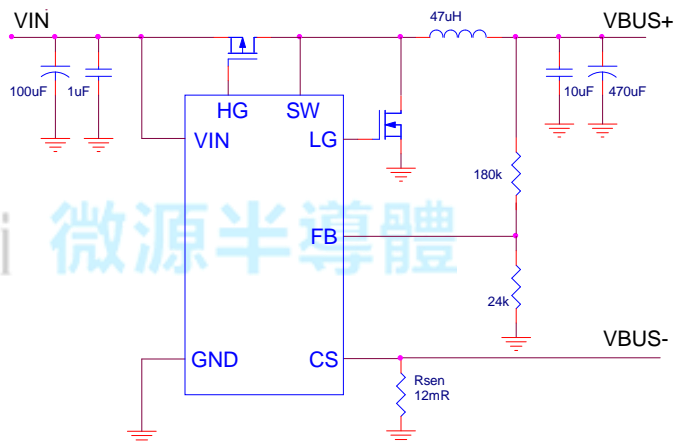

Order Information

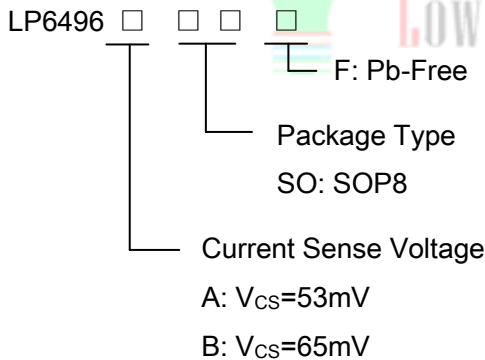

Applications

- ✧ Car Charger / Adaptor
- ✧ LED Driver
- ✧ Pre-Regulator for Linear Regulators
- ✧ Distributed Power Systems
- ✧ Battery Charger

Marking Information

Device	Marking	Package	Shipping
LP6496A	LPS	SOP8	2.5K/REEL
LP6496B	XXX		
Marking indication: Y:Production year W:Production week X:Production batch			



Functional Pin Description

Package Type	Pin Configurations
SOP8	

Pin Description

Pin	Name	Description
1	HG	PMOS Gate Drive.
2	LG	NMOS Gate Drive.
3	SW	Switch PIN.
4	GND	Power Ground.
5	FB	Voltage Feedback. The feedback voltage is 0.6V.
6	CS	Output Current Sense.
7	GND	Ground
8	VIN	Input Supply Voltage.

Function Diagram

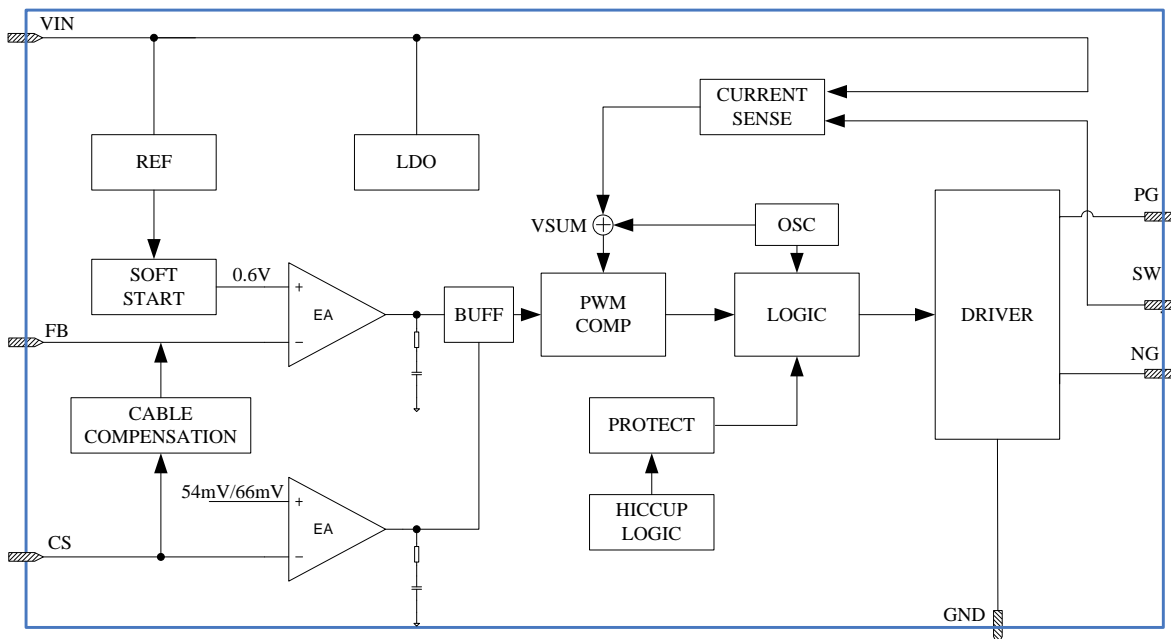



Absolute Maximum Ratings ^{Note 1}

- ◇ VIN to GND----- -0.3V to +43V
- ◇ SW to GND----- -0.3V to +43V
- ◇ HG to GND----- $V_{IN}-6V$ to V_{IN}
- ◇ All other pin to GND----- -0.3V to +6V
- ◇ Storage temperature range----- -55°C to +150°C
- ◇ Maximum Operating Junction temperature ----- 150°C
- ◇ Maximum Soldering Temperature (at leads, 10 sec)----- 260°C

Note 1. Stresses beyond those listed under “Absolute Maximum Ratings” may cause permanent damage to the device. These are stress ratings only, and functional operation of the device at these or any other conditions beyond those indicated in the operational sections of the specifications is not implied. Exposure to absolute maximum rating conditions for extended periods may affect device reliability.

Thermal Information

- ◇ Maximum Power Dissipation ($P_D, T_A=25^\circ C$) ----- 1.5W
- ◇ Thermal Resistance (θ_{JA}) ----- 80°C/W

ESD Susceptibility

- ◇ HBM(Human Body Mode) ----- 2KV
- ◇ MM(Machine Mode) ----- 200V

Recommended Operating Conditions

- ◇ Operating Junction Temperature Range (TJ) ----- -40°C to 150°C
- ◇ Ambient Temperature Range ----- -40°C to 85°C



Electrical Characteristics

$V_{IN}=12V$, $T_A=25^{\circ}C$, unless otherwise noted

Parameter	Symbol	Condition	Min	Typ	Max	Units
Supply Current	I_Q	No switching , $V_{FB}=0.8V$		0.73	1	mA
	I_{SW}	Switching , $I_{load}=0A$		10	20	mA
VIN Under Voltage Lockout Threshold Rising	V_{IN_UVLO}	V_{IN} rising	6.6	7.3	8	V
VIN Under Voltage Lockout Threshold Hysteresis	V_{IN_HYS}			1		V
VIN OVP Voltage Lockout Threshold Rising	V_{IN_OVP}	V_{IN} rising	40	41	42	V
VIN OVP Voltage Lockout Threshold Hysteresis	V_{IN_HYS1}			2.7		V
Oscillator Frequency	F_{SW}	$V_{FB}=0.6V$		180		KHz
Maximum Duty Cycle	D_{MAX}				98	%
FB Voltage Reference	V_{REF}		0.588	0.6	0.612	V
OVP Voltage Reference	V_{OVP}			0.706		V
SCP voltage Reference	V_{REF_SCP}			0.395		V
CS Voltage Reference	V_{CS}	LP6496A	48	53	58	mV
		LP6496B	58	65	72	mV
Line Compensation Current	I_{FB}			1.5		uA
SCP Frequency	F_{SW1}			61		KHz
Current Limit	I_{LIMIT}	$R_{PMOS}=60m$, Duty=50%		4.7		A
		$R_{PMOS}=30m$, Duty=50%		9.3		A
Thermal Shutdown	T_{OTP}	Temp rising		150		$^{\circ}C$
Thermal Shutdown Hysteresis	T_{OTP_HYS}			15		$^{\circ}C$
Hiccup Time	t_{HICCUP}			260		ms
Soft-start Time	t_{SS}			2.7		ms



Application Information

The LP6496 operates by a constant frequency, current mode architecture. The output voltage is set by an external divider returned to the FB pin. An error amplifier compares the divided output voltage with a reference voltage of 0.6V and adjusts the peak inductor current accordingly.

Thermal Protection

The total power dissipation in LP6496 is limited by a thermal protection circuit. When the device temperature rises to approximately 150°C, this circuit turns off the output, allowing the IC to cool. The thermal protection circuit can protect the device from being damaged by overheating in the event of fault conditions. Continuously running the LP6496 into thermal shutdown degrades device reliability.

Current Limit

The Current limit is set by outside resistance (R_{SEN}). When the CS voltage larger than 53mV/65mV, the current limit is happened that driver can be turned off. The current limit set according to the following equation:

$$I_{OUT} = V_{CS} / R_{SEN}$$

Setting Output Voltage

The output voltage is set with a resistor divider from the output node to the FB pin. It is recommended to use divider resistors with 1% tolerance or better. To improve efficiency at very light loads consider using larger value resistors. If the values are too high the regulator is more susceptible to noise and voltage errors from the FB input current are noticeable. For most applications, a resistor in the 10kΩ to 1MΩ range is suggested for R_{UP} and R_{DN} . The output voltage is established by the following equations

$$V_{OUT} = 0.6V \cdot (1 + R_{UP} / R_{DN})$$

Where V_{REF} is 0.6V.

Output Cable Resistance Compensation

To compensate for resistive voltage drop across the charger's output cable, the LP6496 integrates a simple, user-programmable cable voltage drop compensation using the impedance at the FB pin. The delta V_{OUT} rises when the feedback resistance R_{SEN} value rises, use the equation below:

$$\Delta V_{OUT}(mV) = I_{OUT}(A) \cdot R_{SEN}(m\Omega) \cdot R_{UP}(K\Omega) / 40 K\Omega$$



Packaging Information

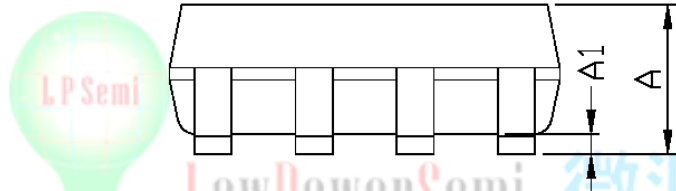
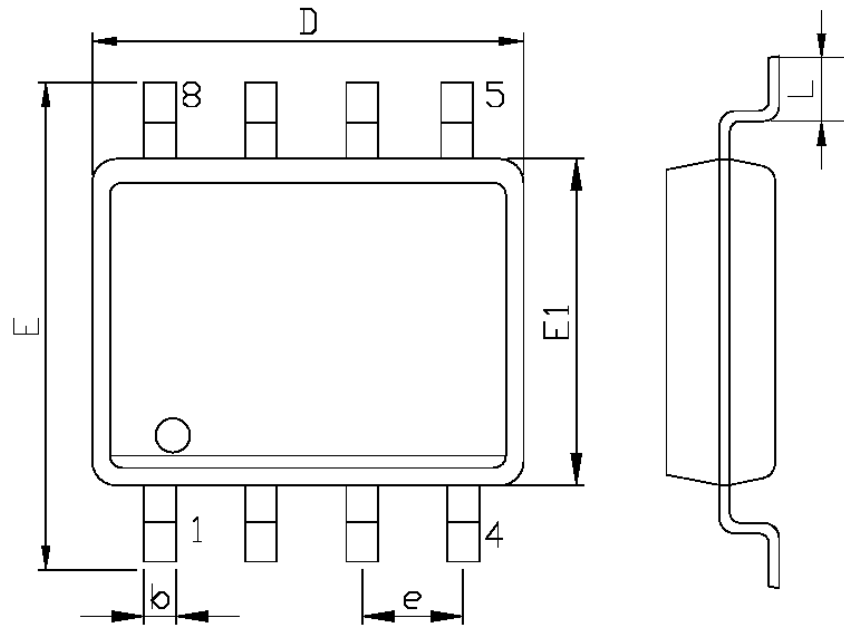

SYMBOLS	MILLIMETERS		INCHES	
	MIN.	MAX.	MIN.	MAX.
A	1.35	1.75	0.053	0.069
A1	0.10	0.25	0.004	0.010
D	4.90		0.193	
E	5.80	6.20	0.228	0.244
E1	3.90		0.153	
L	0.40	1.27	0.016	0.050
b	0.31	0.51	0.012	0.020
e	1.27		0.050	

X-ON Electronics

Largest Supplier of Electrical and Electronic Components

Click to view similar products for [Isolated DC/DC Converters](#) category:

Click to view products by [LOWPOWER](#) manufacturer:

Other Similar products are found below :

[ESM6D044440C05AAQ](#) [FMD15.24G](#) [PSL486-7LR](#) [PSR152.5-7IR](#) [Q48T30020-NBB0](#) [AVO240-48S12B-6L](#) [AVO250-48S28B-6L](#) [NAN-0505](#) [HW-L16D](#) [JAHW100Y1](#) [217-1617-001](#) [22827](#) [SPB05C-12](#) [SQ24S15033-PS0S](#) [18952](#) [19-130041](#) [CE-1003](#) [CE-1004](#) [GQ2541-7R](#) [PSE1000DCDC-12V](#) [RDS180245](#) [MAU228](#) [419-2065-201](#) [449-2075-101](#) [J80-0041NL](#) [V300C24C150BG](#) [419-2062-200](#) [419-2063-401](#) [419-2067-101](#) [419-2067-501](#) [419-2068-001](#) [DCG40-5G](#) [DFC15U48D15](#) [449-2067-000](#) [XGS-0512](#) [XGS-1205](#) [XGS-1212](#) [XGS-2412](#) [XGS-2415](#) [XKS-1215](#) [033456](#) [NCT1000N040R050B](#) [SPB05B-15](#) [SPB05C-15](#) [SSQE48T25025-NAA0G](#) [L-DA20](#) [HP3040-9RG](#) [HP1001-9RTG](#) [XKS-2415](#) [XKS-2412](#)