

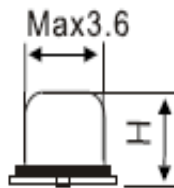

**浙江蓝晶芯微电子有限公司**  
**ZHEJIANG LUCKI CM ELECTRONICS CO., LTD**  
**LK P/N: LOPBS06000U11L**

**CRYSTAL ELECTRICAL SPECIFICATION**

1	Holder Type	HC-49SMD
2	Mode of Vibration	AT CUT
3	Oscillation Mode	Fundamental
4	Nominal Frequency	6.000MHz
5	Load Capacitance	20 pf
6	Frequency Tolerance(25°C)	±20 ppm
7	Effective Series Resistance	80 ohms Max
8	Shunt Capacitance(C0)	7.0pf Max
9	Motional Capcitanace(C1)	N/A
10	Drive Level	100 uW
11	Operation Temperature Range	-40°C~+85°C
12	Stability Over Temperature Range	±30 ppm (related to 25°C)
13	Insulation Resistance	500 Mohms Min.at DC 100V
14	Ration of Holder to Motional(C0/C1)	N/A
15	Storage Temperature	-55°C~ + 105°C
16	Aging	±3 ppm/year

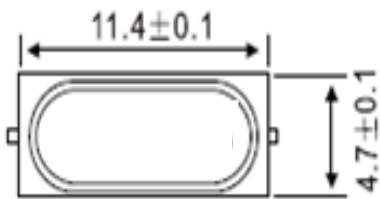

TYPE	H
49S/SMD	3.8
	3.0

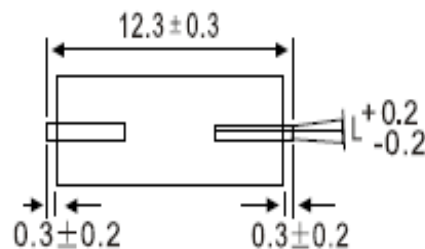
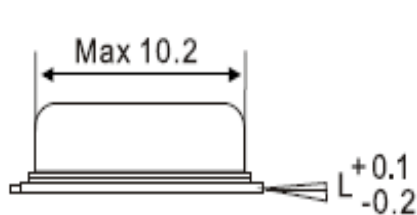

LK P/N: LOPBS06000U11L

# PACKING

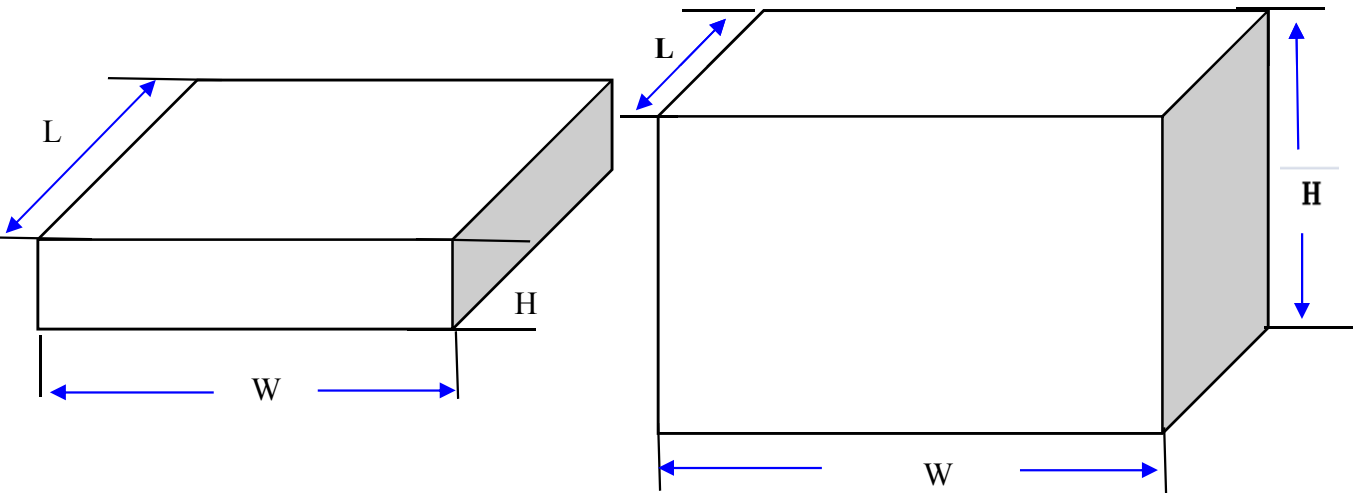
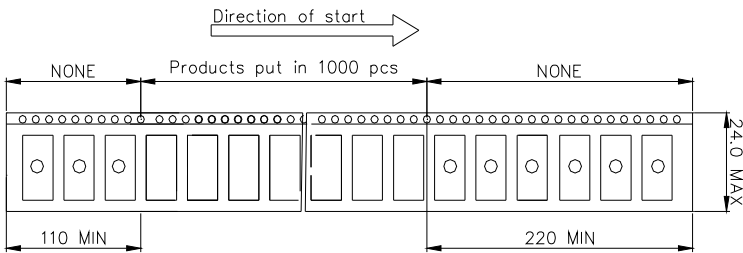
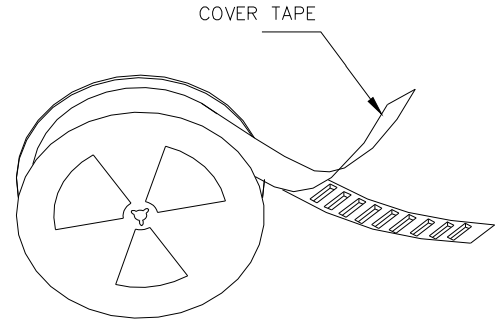
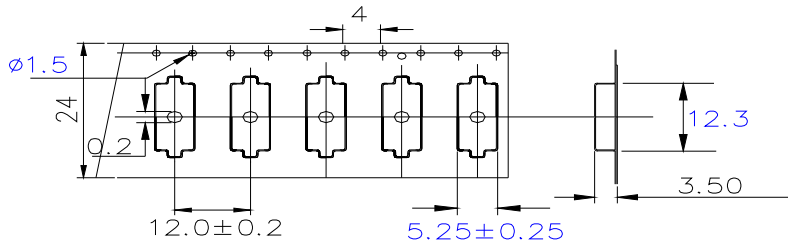

装箱数量	尺寸		
	L(长)	W(宽)	H(高)
内盒	328 mm	328 mm	35 mm
SMD外箱	350 mm	350 mm	200 mm

Tel:0579-88623155 , Fax: 0579-88653155

**RELIABILITY SPECIFIXATIONS**

No.	Test Item	Test Methods
1	Mechanical Endurance 机械特性	Provided that measurement shall be carried out after letting it alone in the room temperature for 1 hour. 试验产品应在室温下放置1小时后方可进行以下试验。
1.1	SHOCK 抗击测试	Electrical characteristics shall be satisfied after dropping three time from the height of 50cm onto Three. 产品从50cm高度自由落下到硬木板3次电气参数仍符合要求。
1.2	VIBRATION 抗振测试	Electrical characteristics shall be satisfied after supplying following Vibration. 电气性能应满足以下的振动要求。 (1) VIBRATION FREQUENCY 振动频率 10—55Hz (2) REPEATED PERIOD 周期 1—2min (3) FULL CYCLE 全振幅 1.5mm P—P (4) DIRECTION 振动方向 X.Y.Z
1.3	STRENGTH OF TERMINALS/LEAD—WIRES 引脚与基座底部的强度测试	
1.3.1	PULLING 拉力测试	a) Body of specimen shall be fixed, and 900g of tension weight shall be supplied gradually to axial direction of terminals/lead-wires for 30 sec .产品应固定在900g的拉力的情况下逐渐延基座底部/引线脚中轴方向拉30秒钟。 b)After above test a), there is no observation of any visual damages on the specimen. 经过a)的测试，产品应没有任何可以目测到的损坏。
1.3.2	BENDING 弯曲度测试	a)Body of specimen shall be fixed, and 90degree bending shall be given, being supplied 225g stension weight .After that, terminals/lead-wires shall be straightened gradually .Then the same bending and straightening shall be supplied to the opposite direction in the same axial . (Refer to Fig-1) 产品固定后，以90o的弯曲并供以225g的拉力，然后沿同一轴线并与相反的方向90 o的弯曲及伸直。（如图1所示） b)After above test a), there is no observation of any visual damages on the specimen . 通过a)测试后，晶体上应没有任何可以目测到的损坏。  The diagram, labeled FIG-1, illustrates the bending test setup and dimensions. On the left, a schematic shows a specimen being held by a 'Tool 工具' and a 'Terminal 端子', with a 'Load 拉力' applied. To the right, two views of the specimen are shown: a side view and a top view. The side view shows a rectangular specimen with a width of 'about 3' (约3) and a radius of 'R about 0.75' (约 R 0.75). The top view shows a circular specimen with a diameter of 'ø1.5' and a height of '6' (mm). FIG-1

**RELIABILITY SPECIFIXATIONS**

No.	Test Item	Test Methods
1.4	SEALING TIGHTNESS 气 密性测试	There is no observation of gas bubble after specimen put in hot water at +90℃—+95℃ for 5 min . 晶体置于+90℃—+95℃的热水中5分钟，应没有气泡产生。
1.5	SOLDERING DIP 浸锡测试	Terminals/lead-wires of specimen shall be dipped into solder melted tank at +230℃—±5℃ for 3sec . Dipping depth shall be 2mm from the bottom of specimens body .(After applying ROSIN flux) Soldering portion shall be covered in over 95% of terminals/lead-wires dipped . 将晶体引线脚置于+260℃—±5℃的锡桶中3分钟，基座底部离锡表面2mm，（加上松香焊剂后）引线脚的沾锡率为95%以上。
1.6	SOLDER HEATING 沾 锡耐热性测试	Terminals/lead-wires of specimen shall be dipped into solder melted tank at +350℃—±10℃ for 3 sec Electrical characteristics shall be satisfied after dipping depth shall be 2mm from edge of terminals/lead-wires . 将已沾锡的产品的引线脚置于+350℃—±10℃的锡桶中3-4秒钟后基座底部离锡表面2mm，电气性能仍符合要求
2	ENVIRONMENTAL ENDURANCE 环境特性	Provided that measurement shall be carried out after letting it alone in the room temperature for 1 hour . 必须将试验产品在室温下放置1小时后方可进行测试。
2.1	HUMIDITY 耐湿测试	Electrical characteristics shall be satisfied after letting it alone at 60℃—±2℃ in humidity of 90—95% for 250 hours . 试验产品在温度为60℃—±2℃，相对湿度90—95%的试验箱内放置250小时后电气性能仍符合要求
2.2	STORAGE IN LOW TEMPERATURE 低温储存测试	Electrical characteristics shall be satisfied after letting it alone at -30℃—±2℃ for 250 hours . 试验产品在温度为-30℃—±2℃的试验箱中放置250小时后电气性能仍符合要求。
2.3	STORAGE IN HIGH TEMPERATURE 高温储存测试	Electrical characteristics shall be satisfied after letting it alone at +85℃—±2℃ for 250 hours . 试验产品在温度为+85℃—±2℃的试验箱中放置250小时后电气性能仍符合要求。
2.4	TEMPERATRRE CYCLE 温 度变换测试	Electrical characteristics shall be satisfied after supplying the following temperature cycle (3cycles) .Temperature shift from low to high, high to low shall be done in 1℃/min (Refer to Fig-2) 电气性能应满足以下温度周期要求（3个周期）温度变换从低到高，从高到低变化量为1℃/分。（如图2所示） 

## X-ON Electronics

Largest Supplier of Electrical and Electronic Components

*Click to view similar products for [Crystals](#) category:*

*Click to view products by [Lucki](#) manufacturer:*

Other Similar products are found below :

[CX3225GB25000M0PPSZ1](#) [718-13.2-1](#) [7A-40.000MAAE-T](#) [FL2000085](#) [99-BU](#) [9B-15.360MBBK-B](#) [9C-7.680MBBK-T](#) [H10S-12.000-18-EXT-TR](#) [ABC2-6.000MHZ-D4Z-T](#) [ABLS-20.000MHZ-D2-T](#) [ABS071-32.768KHZ-6-T](#) [R38-32.768-12.5-5PPM-NPB](#) [BTD1062E05A-513](#) [21U15A-21.4MHZ](#) [RTX-781DF1-S-20.950](#) [LFXTAL066198Cutt](#) [9C-14.31818MBBK-T](#) [A-11.000MHZ-27](#) [ABL-27.000MHZ-B4Y-T](#) [ABM11-132-24.000MHZ-T3](#) [ABM3B1-25.000MHZ-D2Y-T](#) [SPT2A-.032768B](#) [SPT2A.032768G](#) [LFXTAL065253Cutt](#) [LFXTAL066431Cutt](#) [XT9S20ANA14M7456](#) [XT9SNLANA16M](#) [7A-24.576MBBK-T](#) [7B-30.000MBBK-T](#) [CX2520DB16000H0HPQCC](#) [MMCC2R32.7680KHZ](#) [6504-202-1501](#) [6526-202-1501](#) [ABLS-12.000MHZ-B2Y-T](#) [7A-10.000MBBK-T](#) [SG636PCE-20.000MC](#) [3404](#) [CM315D32768EZFT](#) [C1E-24.000-7-2020-R](#) [C1E-19.200-12-1530-X-R](#) [C1E-16.000-12-1530-X-R](#) [ABM11-16.000MHZ-9-B1U-T](#) [FL5000014](#) [EUCA18-3.1872M](#) [FX0800015](#) [425F35E027M0000](#) [FP0800018](#) [MS3V-T1R-32.768kHz-7pF-20PPM-TA-QC-Au](#) [VXM7-1C1-16M000](#) [MS3V-T1R-32.768kHz-9pF-20PPM-TA-QC-Au](#)