



**VOLTAGE RANGE**

100 to 1000 Volts

**CURRENT**

2 Ampere

**Features**

- ◇ Rating to 1000V PRV
- ◇ Surge overload rating to 50 Amperes peak
- ◇ Ideal for printed circuit board
- ◇ Reliable low cost construction utilizing molded plastic technique results in inexpensive product
- ◇ Lead solderable per MIL-STD-202 method 208
- ◇ Plastic material has UL flammability classification 94V-O
- ◇ Glass passivated chip junctions
- ◇ Weight: 0.050 ounces, 1.42 grams

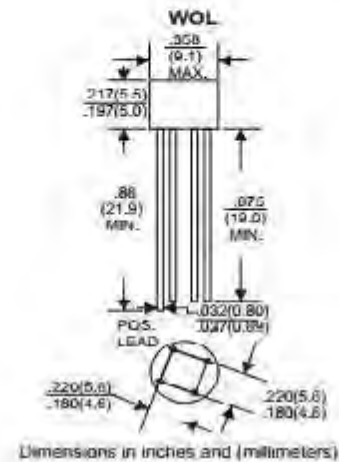

**MAXIMUM RATINGS AND ELECTRICAL CHARACTERISTICS**

Ratings at 25°C ambient temperature unless otherwise specified.

Single phase, half wave, 60 Hz, resistive or inductive load. For capacitive load, derate by 20%.

		2W005	2W01	2W02	2W04	2W06	2W08	2W10	UNITS
Maximum recurrent peak reverse voltage	$V_{RRM}$	50	100	200	400	600	800	1000	V
Maximum RMS voltage	$V_{RMS}$	35	70	140	280	420	560	700	V
Maximum DC blocking voltage	$V_{DC}$	50	100	200	400	600	800	1000	V
Maximum average forward Output current @ $T_A=25^\circ C$	$I_{F(AV)}$	2.0							A
Peak forward surge current 8.3ms single half-sine-wave superimposed on rated load	$I_{FSM}$	50.0							A
Maximum instantaneous forward voltage at 1.0 A	$V_F$	1.0							V
Maximum reverse current @ $T_A=25^\circ C$ at rated DC blocking voltage @ $T_A=100^\circ C$	$I_R$	10.0 1.0							$\mu A$ mA
Operating junction temperature range	$T_J$	- 55 ---- + 150							$^\circ C$
Storage temperature range	$T_{STG}$	- 55 ---- + 150							$^\circ C$

## Ratings AND Characteristic Curves

**FIG.1 – PEAK FORWARD SURGE CURRENT**

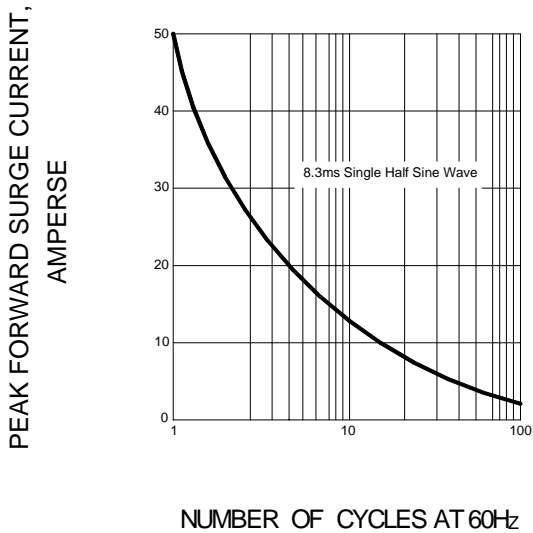

**FIG.2 – FORWARD DERATING CURVE**  
**OUTPUT RECTIFIED CURRENT**

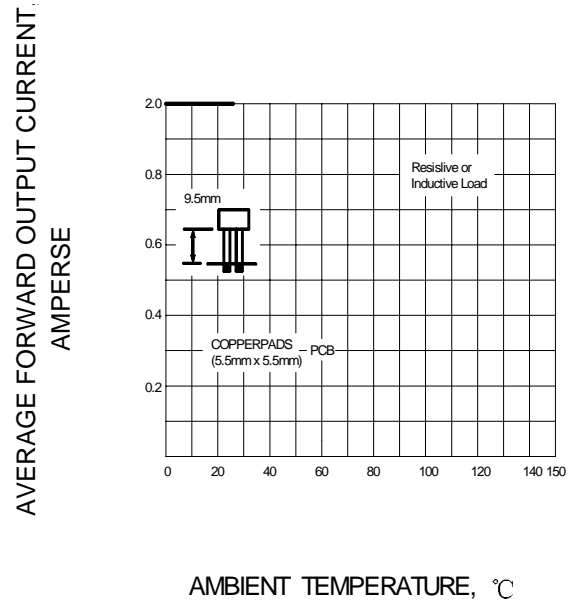

**FIG.3 – TYPICAL FORWARD CHARACTERISTIC**

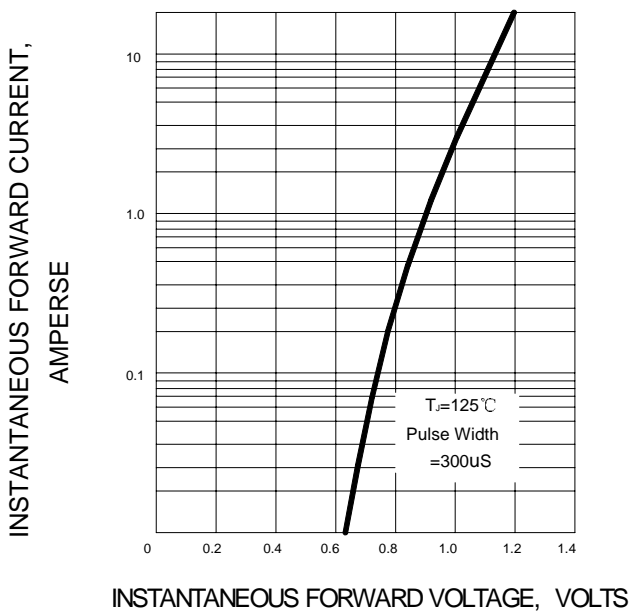

**FIG.4 – TYPICAL REVERSE CHARACTERISTIC**

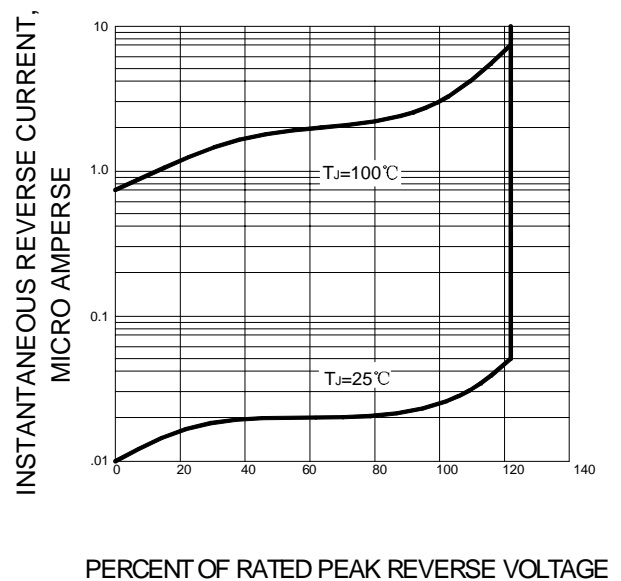

## X-ON Electronics

Largest Supplier of Electrical and Electronic Components

*Click to view similar products for [Bridge Rectifiers](#) category:*

*Click to view products by [Luguang](#) manufacturer:*

Other Similar products are found below :

[MB2510](#) [MB252](#) [MB356G](#) [MB358G](#) [MP358-BP](#) [GBJ1504-BP](#) [GBU15J-BP](#) [GBU15K-BP](#) [GBU4A-BP](#) [GBU4D-BP](#) [GBU6B-E3/45](#)  
[GSIB680-E3/45](#) [DB101-BP](#) [DF01](#) [DF10SA-E345](#) [BU1508-E3/45](#) [KBPC50-10S](#) [RS405GL-BP](#) [G5SBA60-E3/51](#) [GBJ1502-BP](#) [GBU10J-BP](#)  
[GBU4J-BP](#) [GBU6M](#) [GBU8D-BP](#) [GBU8J-BP](#) [GSIB1520-E3/45](#) [2KBB10](#) [36MB140A](#) [TB102M](#) [MB1510](#) [MB258](#) [MB6M-G](#) [MB86](#)  
[TL401G](#) [MDA920A2](#) [TU602](#) [TU810](#) [BR1005-BP](#) [BR101-BP](#) [BR84DTP204](#) [BU2008-E3/51](#) [36MB100A](#) [36MT160](#) [36MT60](#) [KBPC25-02](#)  
[VS-2KBB60](#) [DBB08G-TM-E](#) [DBD250G](#) [DBF20G](#) [DF06SA-E345](#)