



## N31U DIGITAL PANEL METER

- Multi-purpose input for measuring: temperature, resistance, standard signals and potentiometer.
- Programmable unit of measured quantity
- Universal supplying voltage: 24 V...230 V a.c./d.c.
- Two-line LCD display with high contrast and built-in backlighting.
- Possibility of displaying the measured value and time simultaneously or an uncalculated quantity or unit.
- Meter programming from keyboard or through the RS-485 interface by means of the free eCon software.
- 1 alarm output with signalling on LED diodes, working in 7 different modes.
- Storage of minimal and maximal values for all measured quantities.
- Supply of object transducers.
- 32-point individual characteristic for the measured value.
- Mathematical functions for converting the measured value.

FEATURES	INPUTS	OUTPUTS	GALVANIC ISOLATION

### DATA VISUALISATION



or

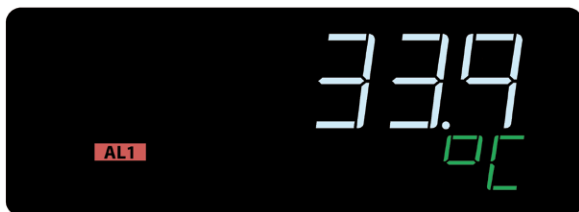

or

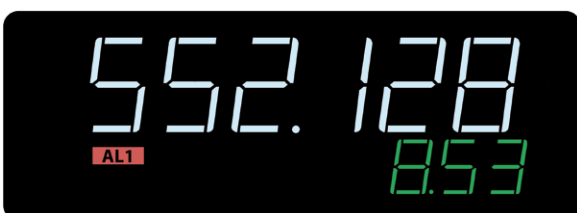

Two-line display.  
Simultaneous preview of the measured value (top line) and the input signal not scaled (bottom line).

Programmable measurement unit  
chosen from 56 variants available  
in the menu.

Preview of current time  
on the bottom line of the display.  
Real-time clock with automatic winter/  
summer time change function.

## INPUT SCALING

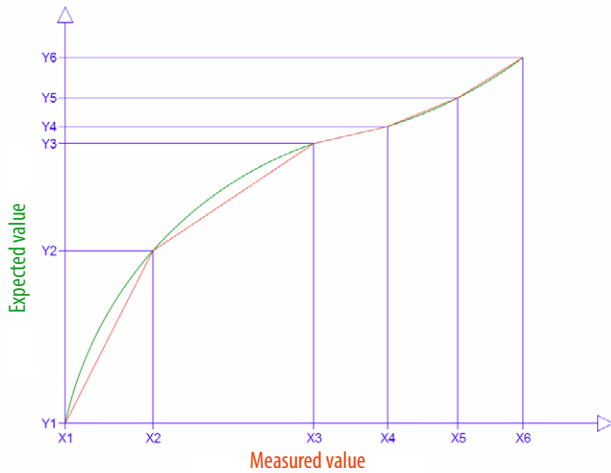

Conversion of the measured quantity based on 32-point individual characteristics. It allows for the mapping of signals from objects or sensors with non-linear characteristics.

$$\sqrt{x} \quad x^2 \quad (1/x)^2$$

$$\sqrt{(1/x)} \quad 1/x$$

Conversion of the measured quantity by means of mathematical functions:  $\sqrt{x}$ ,  $x^2$ ,  $1/x$ ,  $(1/x)^2$ ,  $\sqrt{(1/x)}$

## ALARM FUNCTIONS



1 relay output with the indication on the display.

The alarm can be configured to operate in one of 7 modes, including REG mode for alarm control through RS-485 Modbus.

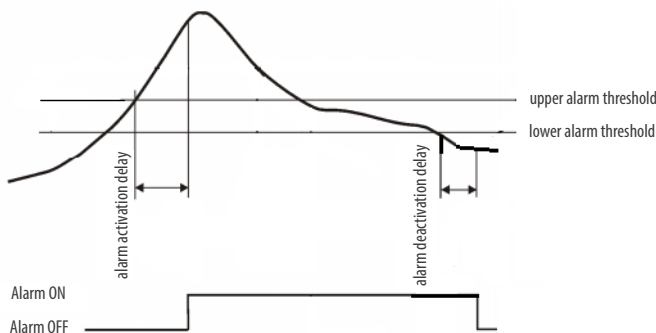

Programmable alarm signal holding. Once the alarm event has ceased, the alarm status marker flashes on the display until it is reset by the user.

$t \geq$  time delay  $\rightarrow$  Alarm activated  
For alarm operation both conditions (value and time delay) must be met

Individually programmable parameters for alarm activation and deactivation delay; the function can be used to prevent "false" alarms.

## ADVANCED MEASUREMENT CONVERSION FUNCTION

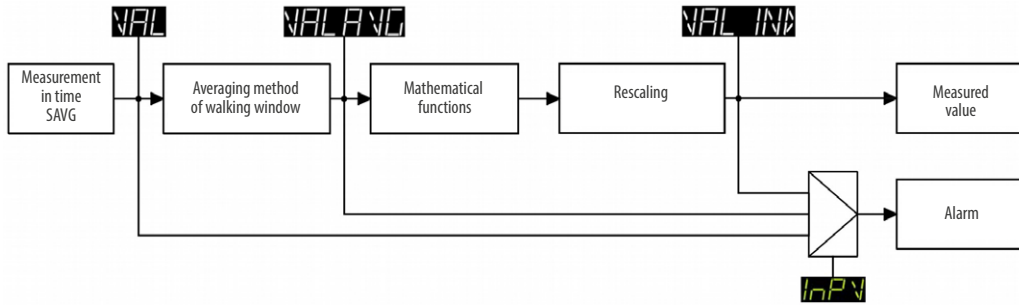

The measured value can be converted in series and the result can be displayed. After each conversion step, the signal can be used as an alarm source.

In practical use, the meter can read the value from an object-oriented transmitter and display the actual value within a limited range, e.g. pressure, level, etc.

This function can be useful in applications where the signal is dynamic. The display can show the values averaged over time (easier signal observation). On the alarm output instead, you can control the signal without additional delays.

## WALKING WINDOW ALGORITHM

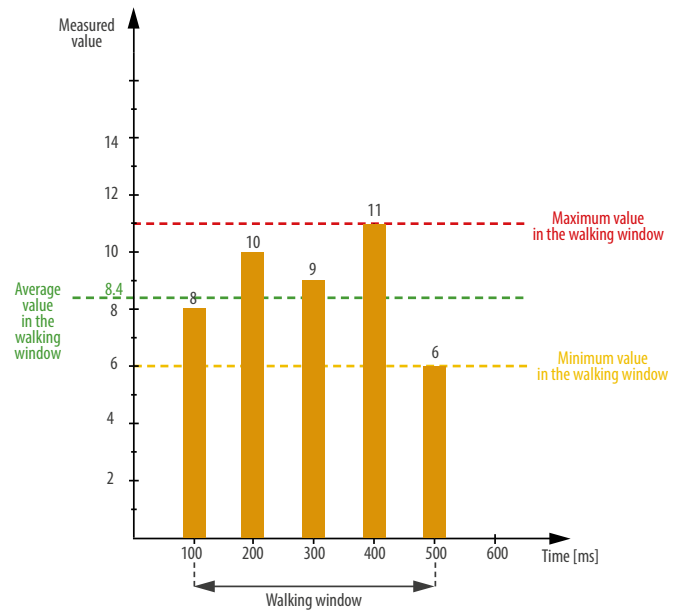
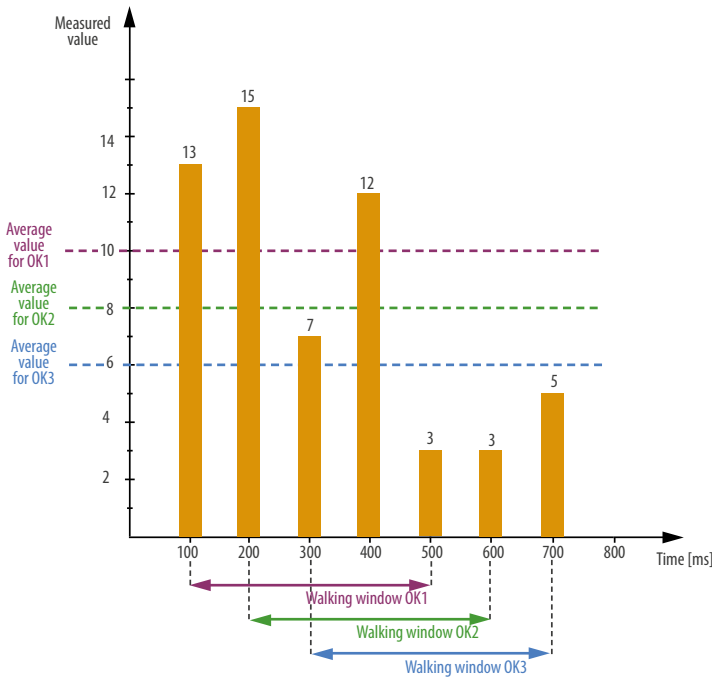

Programmed averaging time according to the walking window algorithm with a set averaging time. This function is useful for measuring high-dynamic signals.

Ability to measure the average, minimum or maximum value when displaying the walking window.

## TECHNICAL DATA

### INPUTS

Input type	Measuring range (nominal range)	Class	Additional error
Pt100	-200...850°C (-200...850°C)	0.1	- due to automatic compensation of the reference junction temperature <1°C - due to automatic compensation of the cable resistance for thermoresistors < 0.5°C - due to automatic compensation of the cables for resistance measurement < 0.2 Ω (range 400 Ω) < 2 Ω (range 4000 Ω) - from temperature changes 50 % of the class/ 10 K
Pt1000	-200...850°C (-200...850°C)		
400 Ω	0...440 Ω (0...400 Ω)		
4000 Ω	0...4040 Ω (0...4000 Ω)		
Thermocouple of E type	-205...1000 °C (-200...1000 °C)		
Thermocouple of J type	-205...1200 °C (-200...1200 °C)		
Thermocouple of K type	-205...1372 °C (-200...1372 °C)		
Thermocouple of N type	-205...1372 °C (-200...1372 °C)		
Thermocouple of R type	-50...1768 °C (-50...1768 °C)		
Thermocouple of S type	-50...1768 °C (-50...1768 °C)		
Voltage input 60 mV	-75...75 mV (-60...60 mV)		
Voltage input 150 mV	-155...155 mV (-150...150 mV)		
Voltage input 300 mV	-310...310 mV (-300...300 mV)		
Voltage input 10 V	-11...11 V (-10...10 V)		
Current input 0...20mA	-24...24 mA (-20...20 mA)	0.2	
Current input 4...20 mA	3.6...22.0 mA (4...20 mA)		
Potentiometer	-0.5...110 (0...100 %)		

### OUTPUTS

Output type	Properties	Remarks
Relay output	• 1 x NO contacts, load-carrying capacity 6A / 250 V a.c.; 6A / 30V d.c.	
Auxiliary supply	24 V d.c./ 24 mA	

### DIGITAL INTERFACE

Interface type	Transmission protocol	Mode	Baud rate
RS-485	MODBUS RTU	8N2, 8E1, 8O1, 8N1	2.4, 4.8, 9.6, 14.4, 19.2, 28.8, 38.4, 57.6, 115.2 kbit/s

### EXTERNAL FEATURES

Readout field	1 row: 6-digits; digits height 12.85 mm 2 row: 5-digits; digits height 7.5 mm	high contrast LCD with backlight and programmable measuring unit
Weight	< 0.2 kg	
Overall dimensions	96 x 48 x 93 mm	mounting hole $92^{+0.6} \times 45^{+0.6}$ mm
Protection grade (acc. to EN 60529)	from frontal side: IP65	from terminal side: IP 10

### RATED OPERATING CONDITIONS

Supply voltage	terminals 17,18	85...253 V a.c. (40...400 Hz), 90...300 V d.c.	power consumption < 3 VA
	terminals 16,17	40...85 V a.c. (40...400 Hz) / 20...300 V d.c.	
Temperature	operation: -20...23...60°C	storage: -30...70°C	
Relative humidity	<95%	without condensation	
Operating position	any		
External magnetic field	0...400 A/m		

### SAFETY AND COMPABILITY REQUIREMENTS

Electromagnetic compatibility	noise immunity	acc. to EN 61000-6-2
	noise emissions	acc. to EN 61000-6-4
Isolation between circuits	basic	acc. to EN 61010-1
Pollution level	2	
Installation category	III	
Maximal phase-to-earth voltage	for supply circuits, alarm, measuring, auxiliary supply: 300 V	
	for RS-485 interface: 50 V	
Altitude a.s.l.	< 2000 m	

## CONNECTION DIAGRAMS

Description of signals on the connection strips

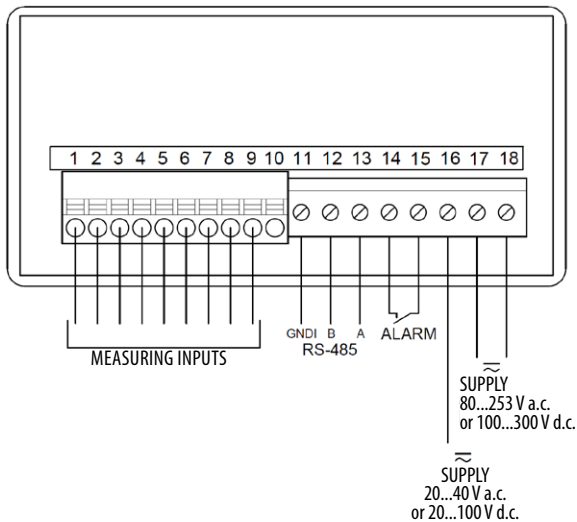

Meter connection

Standard signals 0...10 V  
(range -11...11 V)

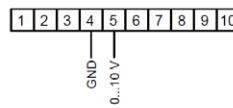

Standard signals 0/4...20 mA  
(range -24...24 mA)

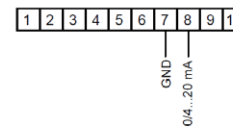

Thermocouples, thermoelectric sensors (thermocouple)

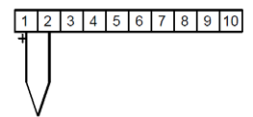

Standard shunts: 60 mV, 150 mV, 300 mV  
(measuring range respectively:  
-75...75 mV, -155...155 mV,  
-310...310 mV)

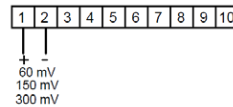

Thermoresistive sensors or resistor in a three-wire system

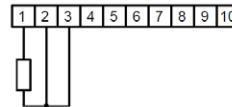

Thermoresistive sensors or resistor in a two-wire system

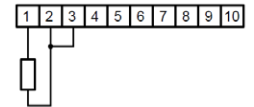

Potentiometer using internal auxiliary supply  
 $R_{min} \geq 500 \Omega$

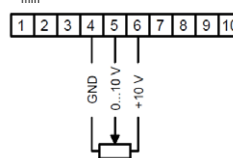

Examples of connecting the external transducers

Connecting the transducer supplied by a current loop (2-wire system 4...20 mA).

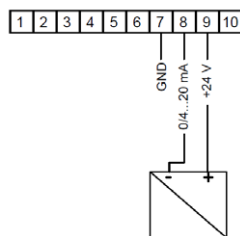

Connecting the transducer with a current output in 3-wire system.

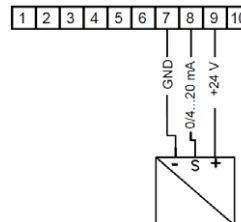

Connecting the transducer with a voltage output in 3-wire system.

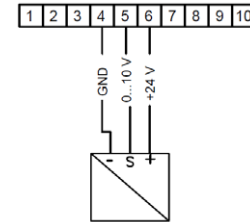

## ORDERING CODE

N31U	X	XXXX
Acceptance tests:		
without an extra calibration certificate		
with an extra calibration certificate	2	
Version:		
standard		
custom-made*		XXXX

\* only after agreeing with the manufacturer

### ORDERING EXAMPLE:

N31U means N31U meter with supply 40... 253 V a.c., 20...300 V d.c., with 1 relay output, RS-485 interface in standard version, polish-english language version, without additional quality requirements.

N31U-19\_en

## X-ON Electronics

Largest Supplier of Electrical and Electronic Components

*Click to view similar products for [LUMEL manufacturer](#):*

Other Similar products are found below :

[ATS 100](#) [ATS 200](#) [ATS 300](#) [ATS 400](#) [ATS 500](#) [B2 060100AA0100M0](#) [B2 06010A0A0100M0](#) [B2 060120AA01A2M0](#) [B2 060160AA01A2M0](#) [B2 0601A00A0100M0](#) [B2 0601K00B0100M0](#) [B2 0601K50B0100M0](#) [B2 060200AA01A2M0](#) [B2 060200AB01B1M0](#) [B2 0602K50B0100M0](#) [B2 06030A0A01A1M0](#) [B2 060350AB01B2M0](#) [B2 060400AB0100MA](#) [B2 06040A0A0100M0](#) [B2 0604A00A0100M0](#) [B2 060500AB01B2M0](#) [B2 06050A0A01A2M0](#) [B2 06060A0A0100M0](#) [B2 060800AB01B3M0](#) [B2 06080A0A01A2M0](#) [B3 15010A0A0100M0](#) [B3 150150AD0100M0](#) [B3 1501A00A0100M0](#) [B3 15025A0A0100M0](#) [B3 15050A0D01A2M0](#) [B3 1505A00A01A1M0](#) [B3 15060A0D0100M0](#) [B4 0502K00B01B5M0](#) [B4 0504K00C0100MA](#) [B4 05050A0D01A2M0](#) [B5 075100AD0100M0](#) [B5 07510A0A0100M0](#) [B5 075125AD01A2M0](#) [B5 07575A0D01A2M0](#) [B6 10010A0A0100M0](#) [B6 100150AD0100M0](#) [B6 100200AD01A2M0](#) [B6 10020A0A01A1M0](#) [B6 10040A0D0100M0](#) [B6 10050A0D01A2M0](#) [BA271NE4090000](#) [BA271NE4160000](#) [BA271NE4170000](#) [BE271NF4170000](#) [BE391NF4122000](#)