

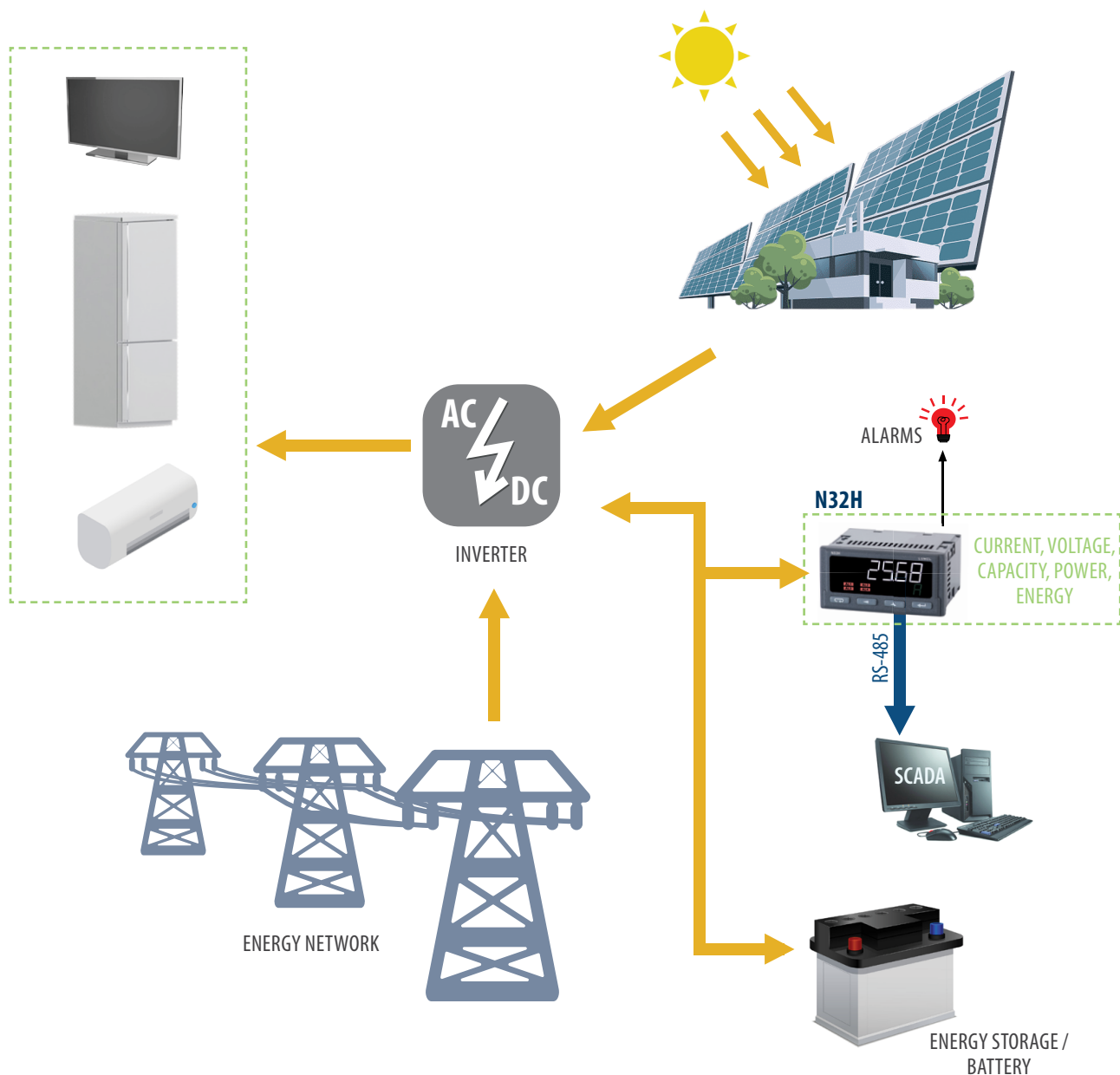

N32H DIGITAL METER OF D.C. CIRCUIT PARAMETERS

- Voltage measurement $\pm 600V$ (maximum range display $\pm 1200 V$), current measurement via shunt, power, energy and capacity measurement of d.c. circuits.
- Two-line LCD display with high contrast and built-in backlighting.
- Possibility of displaying the measured value and time simultaneously or an second measured value or unit (automatically displayed unit of measured quantity).
- Wide range of voltage measurement at the shunt input up to 1500 mV.
- High sampling frequency of measured signals.
- Programming parameters via buttons or RS-485 interface and free e-con software.
- 4 alarm outputs with signaling on led diodes, working in 7 different modes (option).
- Pulse output to control energy consumption.
- Conversion of any measured value into an analog signal 0/4...20 mA or 0...10V (option).
- Memory of minimal and maximal values for all measured quantities.
- Automatic voltage measurement compensation function.

EXAMPLE OF APPLICATION



N32H - DIGITAL METER OF D.C. CIRCUIT PARAMETERS

FEATURES	INPUTS	OUTPUTS	GALVANIC ISOLATION

MEASURED QUANTITIES AND CALCULATED BY THE METER

- d.c. voltage U
- d.c. current I (indirectly through the shunt)
- d.c. power P
- averaged voltage in a given range U_{AV}
- averaged current in a given range I_{AV}
- power averaged in a given range P_{AV}
- capacity counter (accumulated current) CAP
- energy counter E
- maximum and minimum values in the given averaging period
- current time

DATA VISUALISATION

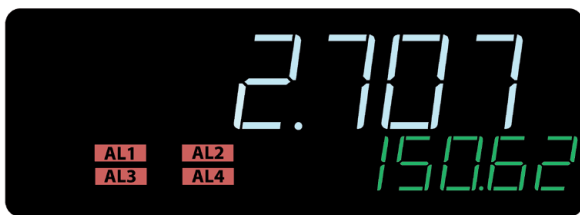

or

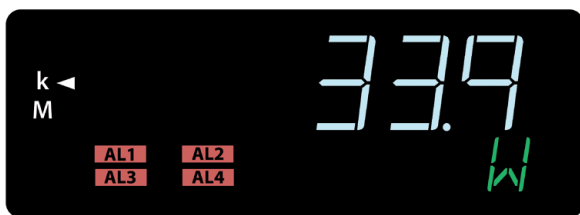

or



Two-line display.
Simultaneous preview of two measured values e.g. current and power.

Automatically displayed unit of measured value and symbol of multiplier kilo, mega.

Preview of current time on the bottom line of the display.
Real-time clock with automatic winter/summer time change function.

BIDIRECTIONAL MEASURING INPUT

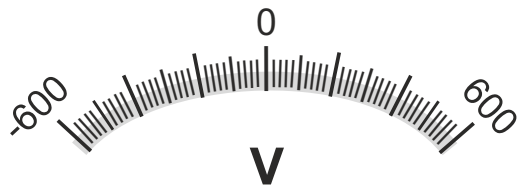

- 50 mV
- 60 mV
- 75 mV
- 100 mV
- 150 mV

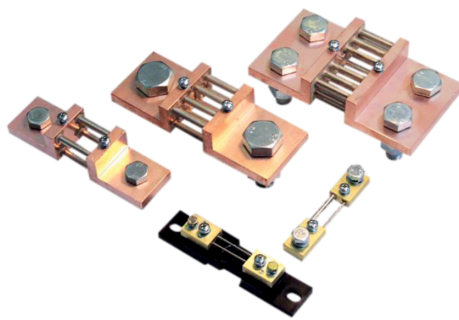

Bidirectional voltage measurement in a wide range of $\pm 600V$ (maximum indication range $\pm 1200V$) and bi-directional current measurement through a shunt. This function is useful, among others when monitoring the parameters of an energy storage system.

Universal input for measuring with any type of shunt with a wide voltage measurement range up to 1500 mV.

Automatic compensation of the voltage drop on the measuring shunt to support the correct measurements of voltage, power and energy in relation to the load.

ALARM FUNCTIONS

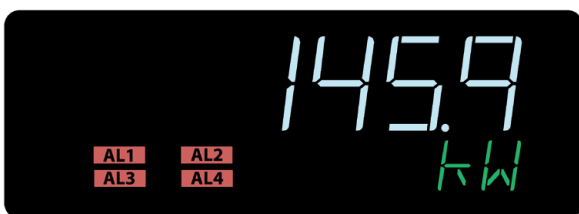

1 or 4 relay outputs with signaling on the display in the form of an active alarm number.

Each of the alarms can be configured to work in one of 7 modes, incl. REG mode for alarm control via RS-485 Modbus.

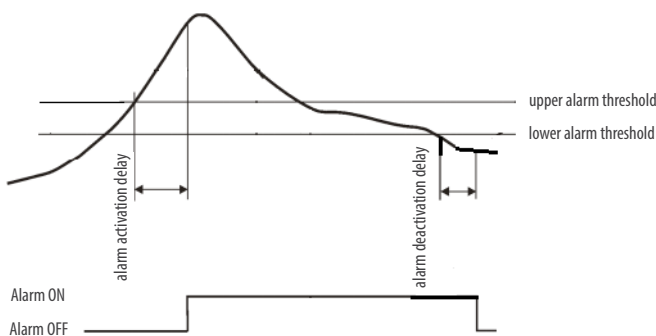

$t \geq$ time delay \rightarrow Alarm activated
For alarm operation both conditions (value and time delay) must be met

Programmable maintenance of alarm signaling. After the alarm event has ceased, the alarm status marker blinks on the display until it is deleted by the user.

Individually programmable parameters of switching on and switching off the alarm; this feature can be used to prevent „false“ alarms from occurring.

WALKING WINDOW ALGORITHM

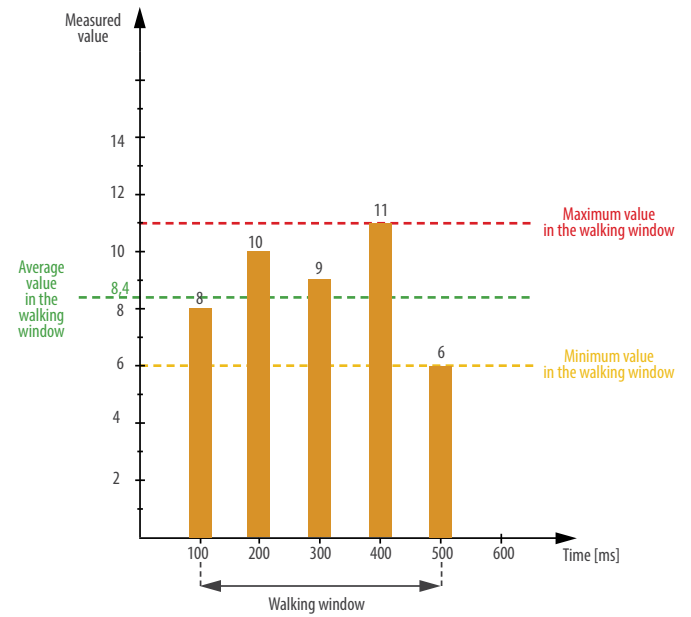
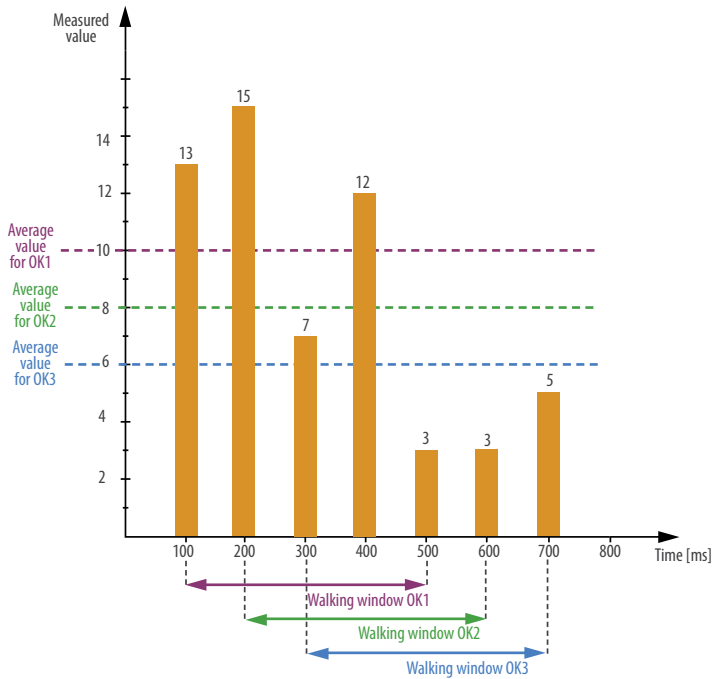

Programmed averaging time according to the walking window algorithm with a given averaging time. This function is useful for measuring signals with high dynamics.

Possibility to measure the average, minimum or maximum value during the walking window.

TECHNICAL DATA

INPUTS AND MEASURING RANGES

Measured quantity	Nominal range	Maximum range of indications	Class
Voltages	50 V	-75...75 V	0.1
	100 V	-160...160 V	
	150 V	-300...300 V	
	300 V	-600...600 V	
	600 V	-1200...1200 V	
Currents (shunt voltage)		60000...60000 A (-1500...1500 mV)	
Capacity (accumulated current)		-99999...999999 MAh	±0.5 %
Power		all ranges	0.2 + shunt class
Energy		-99999...999999 MWh	±0.5 % + shunt class

OUTPUTS

Output type	Properties	Remarks
Relay output	<ul style="list-style-type: none"> 1 NO contact, load capacity 5A / 250V a.c.; 5A / 30V d.c. 3 relays with a changeover contact, load capacity 6A / 250V a.c.; 6A / 30V d.c.; 0,15A / 250V d.c. 	
Analog output	<ul style="list-style-type: none"> programmable current 0/4...20 mA, load resistant ≤ 500 Ω programmable voltage 0...10 V, load resistant ≥ 500 Ω 	Analog output error: 0.1% of the set range Additional error from temperature changes: 50% of class/10K
OC output	OC type, passive npn, 30 V d.c./30 mA	voltage free output

DIGITAL INTERFACE

Interface type	Transmission protocol	Mode	Baud rate
RS-485	MODBUS RTU	8N2, 8E1, 8O1, 8N1	2.4, 4.8, 9.6, 14.4, 19.2, 28.8, 38.4, 57.6, 115.2 kbit/s

EXTERNAL FEATURES

Readout field	1 row 6-digit; digits height 12.85 mm 2 rows: 5-digit; digits height 7.5 mm	high contrast LCD with backlight and programmable measuring unit
Weight	< 0.25 kg	
Overall dimensions	96 x 48 x 93 mm	mounting hole: $92^{+0.6} \times 45^{+0.6}$ mm
Protection grade (acc. to EN 60529)	from frontal side: IP65	from terminal side: IP 10

RATED OPERATING CONDITIONS

Supply voltage	85...253 V a.c. (40...400 Hz), 90...300 V d.c. 20...40 V a.c. (45...65 Hz) / 20...60 V d.c.	power consumption < 6 VA
Temperature	ambient: -25...23...55°C	storage: -30...70°C
Relative humidity	25...95%	without condensation
Operating position	any	
External magnetic field	0...400 A/m	

SAFETY AND COMPABILITY REQUIREMENTS

Electromagnetic compatibility	noise immunity	acc. to EN 61000-6-2
	noise emissions	acc. to EN 61000-6-4
Isolation between circuits	basic	acc. to EN 61010-1
Pollution level	2	
Installation category	III	
Maximal phase-to-earth voltage	for supply circuits: 300 V for other circuits: 50 V	
Altitude a.s.l.	< 2000 m	

CONNECTION DIAGRAMS

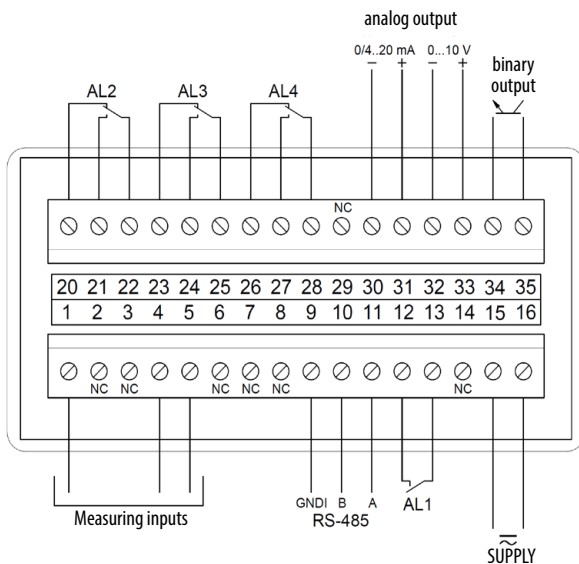

Description of signals on the connector strips

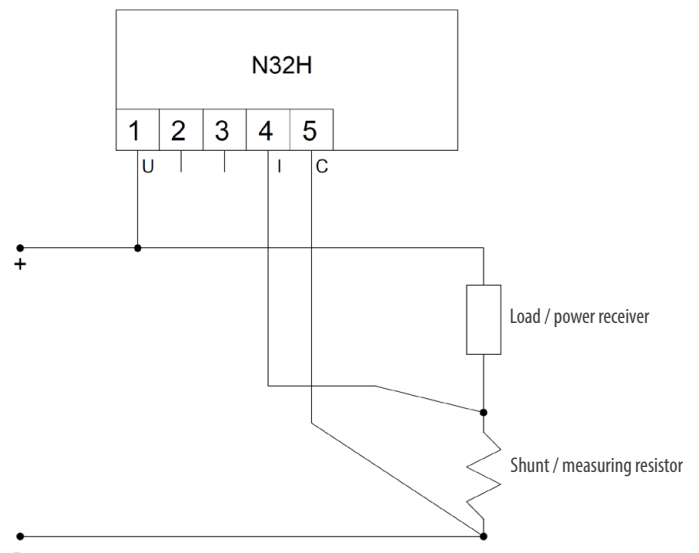

Meter connection

ORDERING CODE

N32H	X	X	XXXXXXXX	X	X
Supply:					
85...253 V a.c., 90...300 V d.c.	1				
20..40 V a.c./ 20..60 V d.c.	2				
Dodatkowe wyjścia:					
1 relay output, RS-485	1				
4 relay outputs, RS-485	2				
4 relay outputs, RS-485, 1 analog output	3				
Version:					
standard			0000000		
custom-made*			XXXXXXXX		
Language:					
Polish/English					M
Acceptance tests:					
without additional quality requirements					0
with an extra quality inspection certificate					1
with an extra calibration certificate					2
acc. to customer's request					X

ORDERING EXAMPLE:

N32H130000000M0 means N32H meter with supply 85...253 V a.c., 90...300 V d.c. with 4 relay outputs, RS-485 interface and 1 analog output, in standard version, polish-english language version, without additional quality requirements.

* only after agreeing with the manufacturer

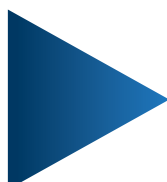

X-ON Electronics

Largest Supplier of Electrical and Electronic Components

Click to view similar products for [LUMEL manufacturer](#):

Other Similar products are found below :

[B2 0602K50B0100M0](#) [B2 0604A00A0100M0](#) [B2 060800AB01B3M0](#) [B3 15010A0A0100M0](#) [B3 15060A0D0100M0](#) [B4 0502K00B01B5M0](#) [B5 07575A0D01A2M0](#) [B6 100150AD0100M0](#) [BA271NE4120000](#) [BA271NE4170000](#) [BA391NE4050000](#) [BE271NF4162000](#) [BE271NF4170000](#) [BE271NF4500000](#) [BE391NF4122000](#) [CA39 120000](#) [EA12N C70200000000](#) [EA12N E20700000000](#) [EA12N E21200000000](#) [EA12N E21300000000](#) [EA12N E41600000000](#) [EA12N E41900000000](#) [EA12N E61500000000](#) [EA12N F41300000000](#) [EA16N E20700000A0](#) [EA16N E20900000A0](#) [EA16N E41300000A0](#) [EA16N E41700000A0](#) [EA17N E20800000000](#) [EA17N E21000000000](#) [EA17N E21200000000](#) [EA17N E21400000000](#) [EA17N E40800000000](#) [EA17N E41900000000](#) [EA17N F21000000000](#) [EA19N C70300000000](#) [EA19N E21400000000](#) [EA19N E41600000000](#) [EA19N E42100000000](#) [EA19N E61400000000](#) [EA19N E61500000000](#) [EA19N F21500000000](#) [EB16N E20500000A0](#) [EB16N E20600000A0](#) [EB16N E61300000A0](#) [EB16N E61400000A0](#) [EP27NC7230000](#) [EP27NE7020000](#) [EP27NE7090000](#) [EP27NE7100000](#)