

UNCONTROLLED DOCUMENT

PART NUMBER
SSF-LXH100HD

REV.
B

| REV. | E.C.N. NUMBER AND REVISION COMMENTS | DATE |
|------|-------------------------------------|---------|
| A | E.C.N. #10301. | 1.30.97 |
| B | E.C.N. #10BRDR. & REDRAWN IN 3D. | 5.14.02 |

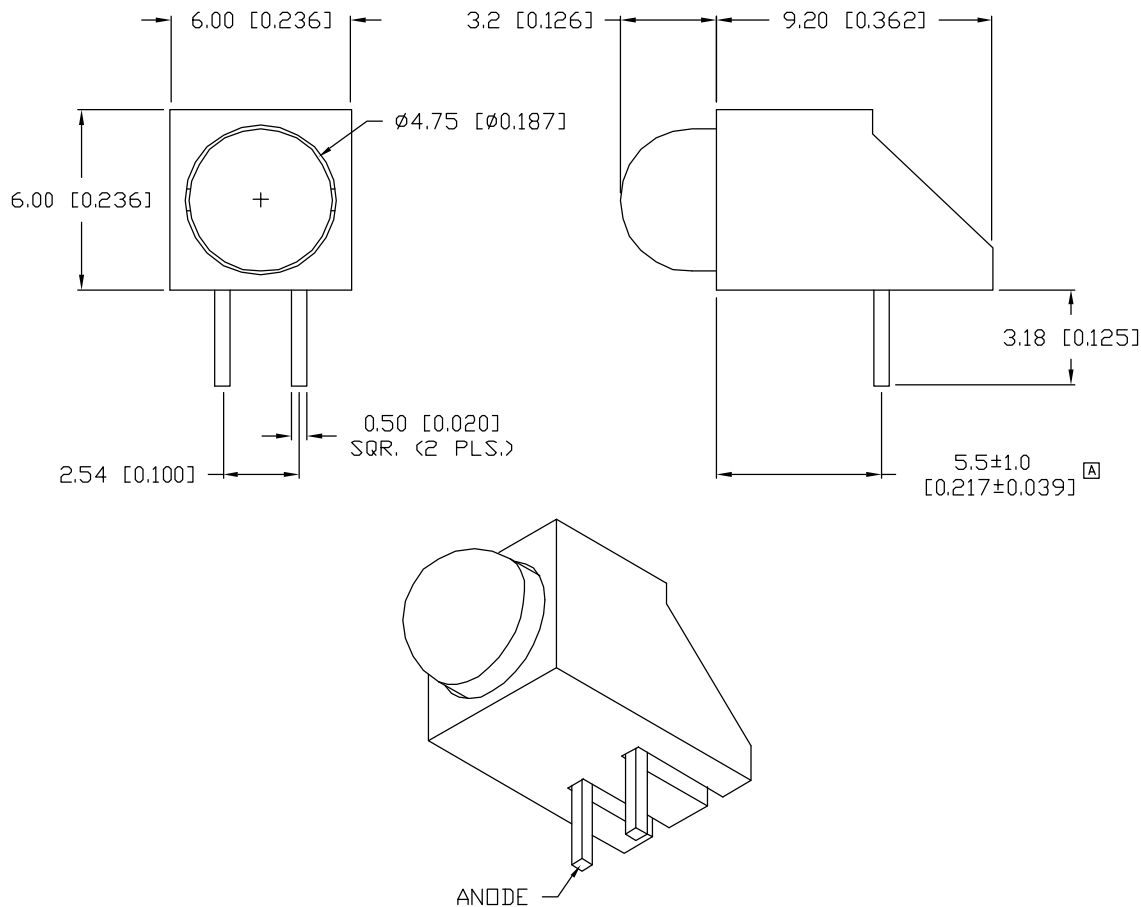

ELECTRO-OPTICAL CHARACTERISTICS $T_A=25^{\circ}\text{C}$ $I_f=20\text{mA}$

| PARAMETER | MIN | TYP | MAX | UNITS | TEST COND |
|--------------------|--------------|-----|-----|----------|----------------------|
| PEAK WAVELENGTH | | 700 | | nm | |
| FORWARD VOLTAGE | | 2.0 | 2.5 | V_f | |
| REVERSE VOLTAGE | 5.0 | | | V_r | $I_f=100\mu\text{A}$ |
| AXIAL INTENSITY | | 6 | | mcd | $I_f=20\text{mA}$ |
| VIEWING ANGLE | | 60 | | 2x theta | |
| EMITTED COLOR: | RED | | | | |
| EPOXY LENS FINISH: | RED DIFFUSED | | | | |

▣ LIMITS OF SAFE OPERATION AT 25°C

| PARAMETER | MAX | UNITS |
|----------------------------------|------------|------------------------------|
| PEAK FORWARD CURRENT* | 150 | mA |
| STEADY CURRENT | 25 | mA |
| POWER DISSIPATION | 120 | mW |
| DERATE FROM 25°C | -1.2 | $\text{mW}/^{\circ}\text{C}$ |
| OPERATING, STORAGE TEMP. | -40 TO +85 | $^{\circ}\text{C}$ |
| SOLDERING TEMP. | +260 | $^{\circ}\text{C}$ |
| 2.0mm FROM BODY | | 3 SEC. MAX |

* $t < 10\mu\text{s}$

NOTES:

1. SSL-LX507F3HD, RED LED.
2. SSH-LXH100, BLACK HOLDER.

UNCONTROLLED DOCUMENT

*UNLESS OTHERWISE SPECIFIED TOLERANCES PER DECIMAL PRECISION ARE: X=±1 (±0.039), X.X=±0.5 (±0.020), X.XX=±0.25 (±0.010), X.XXX=±0.127 (±0.005). LEAD SIZE=±0.05 (±0.002), LEAD LENGTH=±0.75 (±0.030). MIN.=⁺DECIMAL PRECISION MAX.=⁺0.00
-0.00 -DECIMAL PRECISION

| | |
|--|-----------------------------|
| REV. B | PART NUMBER SSF-LXH100HD |
| T-5mm (T-1 3/4) LED, RIGHT ANGLE FAULT INDICATOR, 700nm RED LED, RED DIFFUSED LENS. | |

CONFIDENTIAL INFORMATION
THE INFORMATION CONTAINED IN THIS DOCUMENT IS THE PROPERTY OF LUMEX INC. EXCEPT AS SPECIFICALLY AUTHORIZED IN WRITING BY LUMEX INC., THE HOLDER OF THIS DOCUMENT SHALL KEEP ALL INFORMATION CONTAINED HEREIN CONFIDENTIAL AND SHALL PROTECT SAME IN WHOLE OR IN PART FROM DISCLOSURE AND DISSEMINATION TO ALL THIRD PARTIES.

RELIABILITY NOTE
OUR MANY YEARS OF EXPERIENCE DATA ACCUMULATION INDICATE THAT SOLDER HEAT IS A MAJOR CAUSE OF EARLY AND FUTURE FAILURE. PLEASE PAY ATTENTION TO YOUR SOLDERING PROCESS.

| | | |
|--|---|---|
| | 290 E. HELEN ROAD PALATINE, IL 60067-6976 PHONE: +1.847.359.2790 US WEB: www.lumex.com TW WEB: www.lumex.com.tw | |
| | DRAWN BY: BC | CHECKED BY: |
| | | DATE: 5.16.94 PAGE: 1 OF 1 SCALE: N/A |

X-ON Electronics

Largest Supplier of Electrical and Electronic Components

Click to view similar products for [LED Circuit Board Indicators](#) category:

Click to view products by [Lumex](#) manufacturer:

Other Similar products are found below :

[568-0200-132F](#) [568-0701-841F](#) [568-0734-832F](#) [569-0312-300F](#) [591-2001-107F](#) [592-2424-302F](#) [LTL-4221NH129](#) [LTL-42DGNMHDP1](#)
[LTM-260-5HT](#) [H131CSRT-120](#) [HLMP1503108F](#) [HLMP1521101](#) [HLMP1523802F](#) [HLMP1700101F](#) [HLMP1700104F](#) [HLMP1790105F](#)
[BHA-1564-G](#) [SMF-HM1530YD-305](#) [SSF-LXH103SUGD-04](#) [AM2520EHSGD](#) [HLMP1301104F](#) [HLMP1385101F](#) [HLMP1421101](#)
[HLMP1503103F](#) [HLMP1503104F](#) [HLMP1700102F](#) [HLMP1700106F](#) [HLMP1700107F](#) [HLMP1790101F](#) [HLMP1790103F](#) [LTL-4211NHBP](#)
[5320F7](#) [5330H7](#) [5350T7](#) [5352T1-5VLC](#) [5352T5-5VLC](#) [5370T7LC](#) [550-1112F](#) [550-3107-010F](#) [551-0206-003F](#) [551-0207-815F](#) [551-0212-](#)
[801F](#) [551-2802F](#) [552-0794-810F](#) [552-0821F](#) [552-6033-200F](#) [553-0001-808F](#) [553-0122-818F](#) [553-0171F](#) [553-0181F](#)