



## 1 TABLE OF CONTENTS

1	<b>TABLE OF CONTENTS</b>	0
2	<b>REVISION HISTORY</b>	1
3	<b>FEATURES</b>	2
4	<b>SPECIFICATIONS</b>	2
5	<b>PIN CONFIGURATION</b>	2
6	<b>PACKAGE OUTLINE DIMENSION</b>	3/4
7	<b>ORDERING INFORMATION</b>	5
8	<b>PIN DESCRIPTION</b>	5
9	<b>POWER-UP INITIALIZATION</b>	6
10	<b>INTERFACE DESCRIPTION</b>	7
10.1	<i>Address Space</i>	7
10.2	<i>Page Size</i>	7
10.3	<i>Drive Strength</i>	7
10.4	<i>Power-on Status</i>	7
10.5	<i>Truth Table</i>	8
10.6	<i>Command Termination</i>	9
11	<b>WRAP BOUNDARY TOGGLE OPERATION</b>	10
12	<b>SPI MODE OPERATIONS</b>	11
12.1	<i>SPI Read Operations</i>	11/12
12.2	<i>SPI Write Operations</i>	12
12.3	<i>SPI Quad Mode Enable Operation</i>	13
12.4	<i>SPI Read ID Operation</i>	13/14
13	<b>QPI MODE OPERATIONS</b>	14
13.1	<i>QPI Read Operations</i>	14
13.2	<i>QPI Write Operation(s)</i>	14
13.3	<i>QPI Quad Mode Exit Operation</i>	15
14	<b>RESET OPERATION</b>	16
15	<b>INPUT / OUTPUT TIMING</b>	17
16	<b>ELECTRICAL SPECIFICATIONS</b>	18
16.1	<i>Absolute Maximum Ratings</i>	18
16.2	<i>Pin Capacitance</i>	18
16.3	<i>Operating Conditions</i>	18
16.4	<i>DC Electrical Characteristics</i>	19
16.5	<i>AC Electrical Characteristics</i>	19



## 2 REVISION HISTORY

<u>Revision</u>	<u>Description</u>	<u>Issue Date</u>
Rev. 0.1	Initial Issue	May.06.2016
Rev. 0.2	Revised typos	May.19.2016
Rev. 0.3	Revised the address bit length from 32 bits to 24 bits	Oct.13.2016
Rev. 0.4	Added <b>Command Termination</b> in page 7 Revised <b>Truth Table</b> in page 7	May.03.2017
Rev. 0.5	Reworded linear burst, renamed page toggle CMDs. Updated timing parameters for 144MHz. Removed QPI Read 'h0B support. Clarified termination section. Added <b>Pin Capacitance</b> tables. Extend $t_{CHD}$ to 20ns & $t_{CPH}$ to 50ns.	Jul.20.2017
Rev. 0.6	Added <b>Truth Table</b> note: 2. Linear burst is prohibited. Added <b>Table 3: Burst Type / Length</b> in page 10	Aug.04.2017
Rev. 0.7	Revised temperature range to -40 ~ 85°C	Nov.21.2017

### 3 FEATURES

- 50Ω Output Drive Strength LVCMOS.
- Linear Burst (continuous) or 32 byte wrapped burst via toggle command.
- Linear Burst is supported up to 84MHz and can cross page boundary as long as  $t_{CEM}$  is met.
- Software reset.
- **Green package available**
- Package : 8-pin 150mil SOP  
8-pin 5mm x 6mm WSON

### 4 SPECIFICATIONS

- Single Supply Voltage:
  - $V_{CC}=2.7$  to  $3.6V$
- Interface: SPI/QPI with SDR mode
- Performance: Clock rate up to
  - 144MHz (non-page boundary crossing)
  - 84MHz (page boundary crossing)
- Organization: 64Mb, 8M x 8bits
- Addressable bit range: A[22:0]
- Page size: 1024 bytes
- Refresh: Self-managed
- Operating temperature range
  - $TC = -40^{\circ}C$  to  $+85^{\circ}C$
- Maximum Standby Current:
  - $400\mu A @ 85^{\circ}C$

### 5 PIN CONFIGURATION

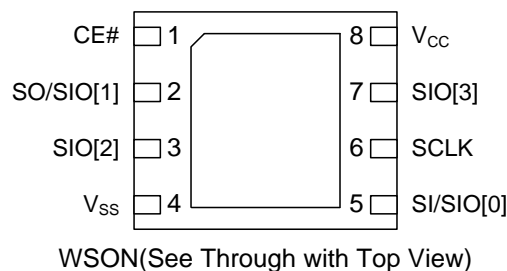
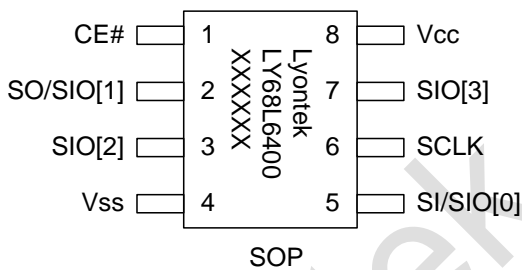

## 6 PACKAGE OUTLINE DIMENSION

### 8-pin 150mil SOP Package Outline Dimension

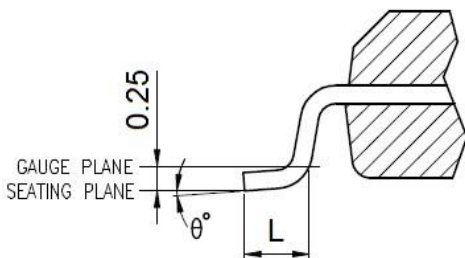
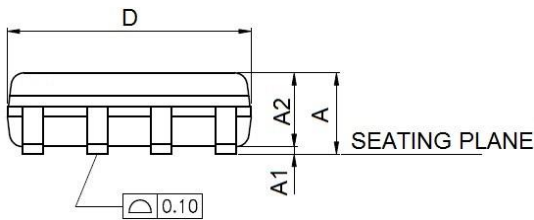
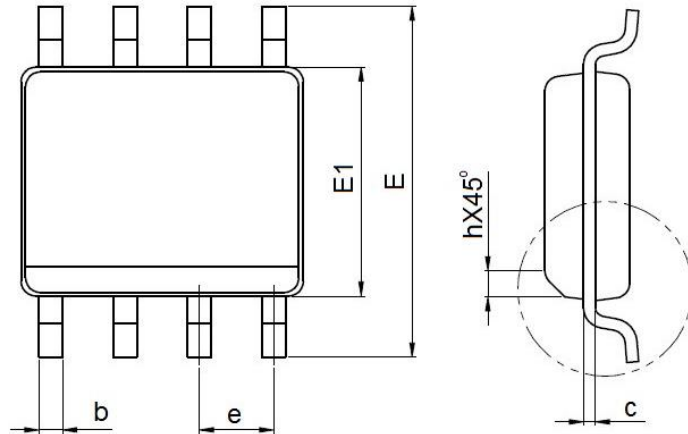

VARIATIONS (ALL DIMENSIONS SHOWN IN MM)

SYMBOLS	STANDARD	
	MIN.	MAX.
A	—	1.75
A1	0.10	0.25
A2	1.25	—
b	0.31	0.51
c	0.10	0.25
D	4.90 BSC	
E	6.00 BSC	
E1	3.90 BSC	
e	1.27 BSC	
L	0.40	1.27
h	0.25	0.50
$\theta^\circ$	0	8

#### NOTES:

1. JEDEC OUTLINE : MS-012 AA REV.F (STANDARD)  
MS-012 BA REV.F (THERMAL)
2. DIMENSIONS "D" DOES NOT INCLUDE MOLD FLASH, PROTRUSIONS OR GATE BURRS. MOLD FLASH, PROTRUSIONS AND GATE BURRS SHALL NOT EXCEED 0.15mm. PER SIDE.
3. DIMENSIONS "E1" DOES NOT INCLUDE INTER-LEAD FLASH, OR PROTRUSIONS. INTER-LEAD FLASH AND PROTRUSIONS SHALL NOT EXCEED 0.25mm PER SIDE.



**8-pin 5mm x 6mm WSON Package Outline Dimension**

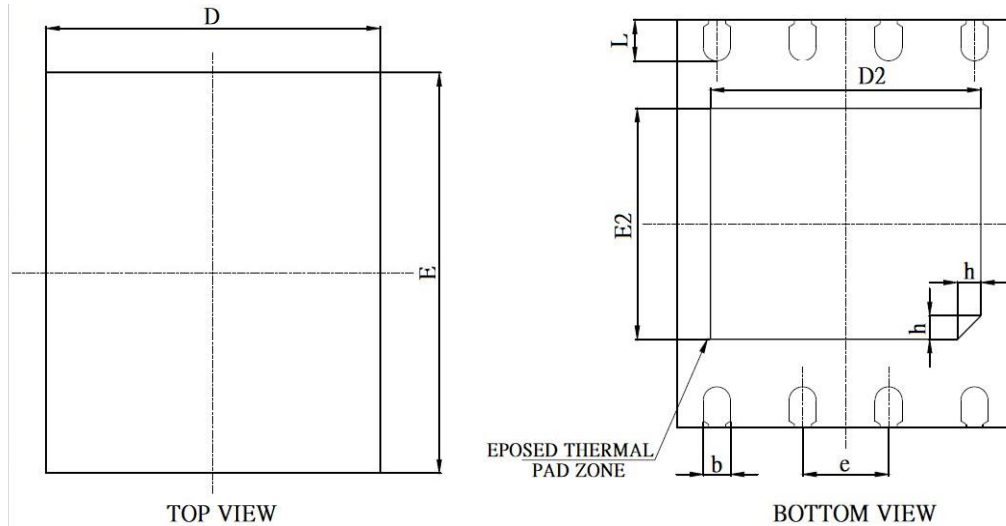

SYMBOL	MILLIMETER		
	MIN	NOM	MAX
A	0.70	0.75	0.80
A1	0	0.02	0.05
b	0.35	0.40	0.48
c	0.18	0.203	0.25
D	4.90	5.00	5.10
e	1.27 BSC		
E	5.90	6.00	6.10
D2	3.90	4.00	4.10
E2	3.30	3.40	3.50
L	0.55	0.60	0.65
h	0.30	0.35	0.40

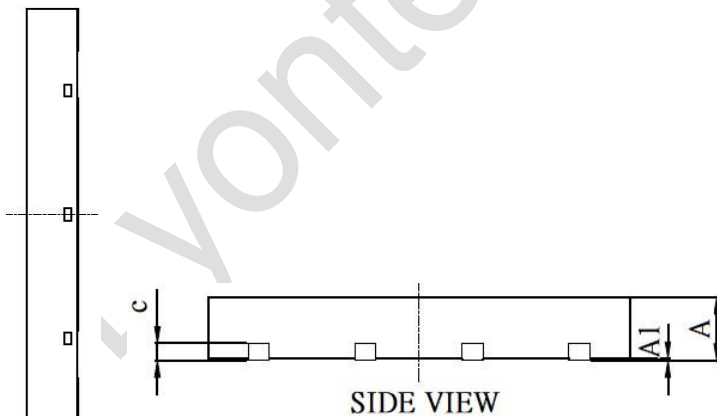

NOTES :

1. ALL DIMENSIONS ARE IN MILLIMETERS.
2. DIMENSION b APPLIES TO METALLIZED TERMINAL AND IS MEASURED BETWEEN 0.15mm AND 0.30mm FROM THE TERMINAL TIP. IF THE TERMINAL HAS THE OPTIONAL RADIUS ON THE OTHER END OF THE TERMINAL, THE DIMENSION b SHOULD NOT BE MEASURED IN THAT RADIUS AREA.



## 7 ORDERING INFORMATION

Table 1: Ordering Information

Package Type	Maximum Clock Rate(MHz)	Temperature Range(°C)	Packing Type	Lyontek Item No.
8-pin (150mil) SOP	144	-40°C ~85°C	Tube	LY68L6400SLI
			Tape Reel	LY68L6400SLIT
8-pin (5mm x 6mm) WSON	144	-40°C ~85°C	Tray	LY68L6400BLI
			Tape Reel	LY68L6400BLIT

## 8 PIN DESCRIPTION

Table 2: Signals Table

SYMBOL	TYPE	SPI Mode Function	QPI Mode Function	COMMENTS
V <sub>CC</sub>	Power	Core supply 3V		
V <sub>SS</sub>	Ground	Core supply ground		
CE#	Input	Chip select, active low. When CE#=1, chip is in standby state.		
CLK	Input	Clock Signal		
SI/SIO[0]	I/O	Serial Input	I/O[0]	
SO/SIO[1]	I/O	Serial Output	I/O[1]	
SIO[2]	I/O	-	I/O[2]	
SIO[3]	I/O	-	I/O[3]	



## 9 POWER-UP INITIALIZATION

SPI/QPI products include an on-chip voltage sensor used to start the self-initialization process. When  $V_{CC}$  reaches a stable level at or above minimum  $V_{CC}$ , the device will require  $150\mu s$  and user-issued RESET Operation (see section 14) to complete its self-initialization process. From the beginning of power ramp to the end of the  $150\mu s$  period, CLK should remain LOW, CE# should remain HIGH (track  $V_{CC}$  within 200mV) and SI/SO/SIO[3:0] should remain LOW.

After the  $150\mu s$  period the device is ready for normal operation.

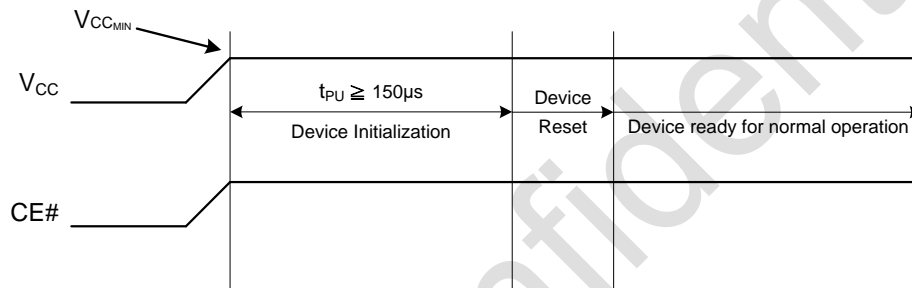

Figure 1 : Power-Up Initialization Timing



## **10 INTERFACE DESCRIPTION**

### **10.1 Address Space**

SPI/QPI PSRAM device is byte-addressable. 64M device is addressed with A[22:0].

### **10.2 Page Size**

Page size is 1K (CA[9:0]). Default burst setting is Linear Bursting that crosses page boundary in a continuous manner. Note however that burst operations which cross page boundary have a lower max input clock frequency of 84MHz. Optionally the device can also be set to wrap 32 (CA[4:0]) via the Wrap Boundary Toggle command and is not allowed to cross page boundary in this configuration.

### **10.3 Drive Strength**

The device powers up in 50Ω.

### **10.4 Power-on Status**

The device powers up in SPI Mode. It is required to have CE# high before beginning any operations.





### 10.5 Truth Table

The device recognizes the following commands specified by the various input methods.

COMMAND	CODE	SPI Mode (QE=0)					QPI Mode (QE=1)				
		CMD	Addr	Wait Cycle	DIO	MAX. Freq.	CMD	Addr	Wait Cycle	DIO	MAX. Freq.
Read	'h03	S	S	0	S	33	N/A				
Fast Read	'h0B	S	S	8	S	144	N/A				
Fast Read Quad	'hEB	S	Q	6	Q	144	Q	Q	6	Q	144*1
Write	'h02	S	S	0	S	144*2	Q	Q	0	Q	144*1
Quad Write	'h38	S	Q	0	Q	144	Same as 'h02				
Enter Quad Mode	'h35	S	-	-	-	144	N/A				
Exit Quad Mode	'hF5	N/A					Q	-	-	-	144
Reset Enable	'h66	S	-	-	-	144	Q	-	-	-	144
Reset	'h99	S	-	-	-	144	Q	-	-	-	144
Set Burst Length	'hC0	S	-	-	-	144	Q	-	-	-	144
Read ID	'h9F	S	S	0	S	144	N/A				

Remarks: S = Serial I/O, Q = Quad I/O

Note: 1. 144MHz max without crossing page boundary, and 84MHz max when burst commands cross page boundary.  
2. Linear burst is prohibited.

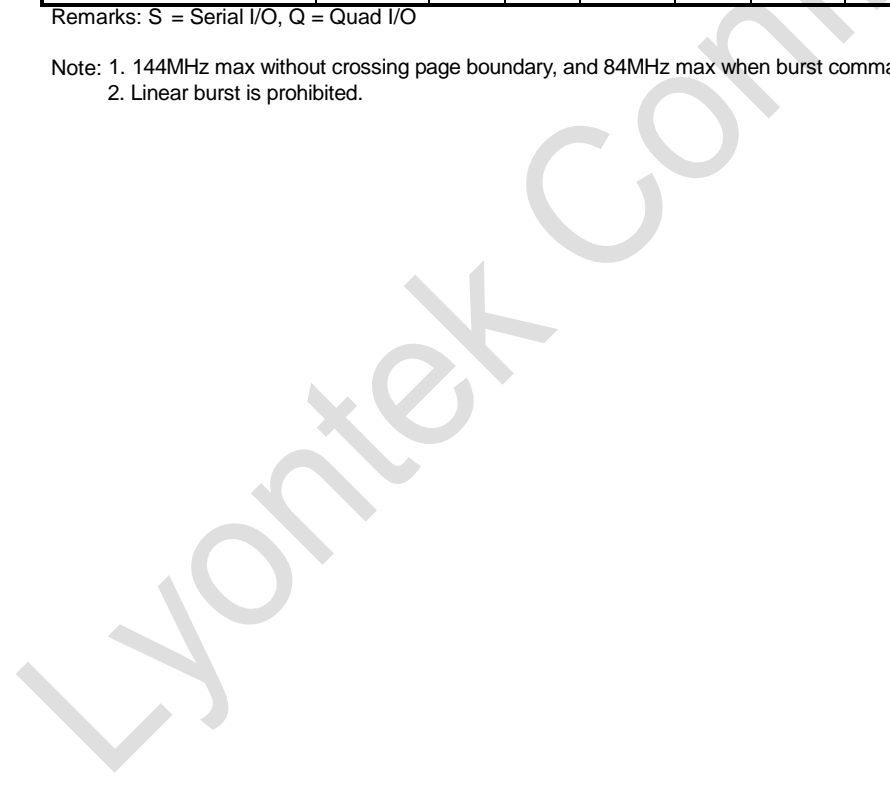

### 10.6 Command Termination

All Reads & Writes must be completed by raising CE# high immediately afterwards in order to terminate the active command and set the device into standby. Not doing so will block internal refresh operations and cause memory failure.

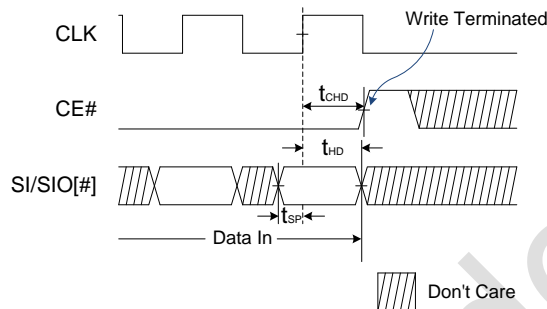

**Figure 2 : Write Command Termination**

For a memory controller to correctly latch the last piece of data prior to read termination, it is recommended to provide a longer CE# hold time ( $t_{CHD} > t_{ACLK} + t_{CLK}$ ) for a sufficient data window.

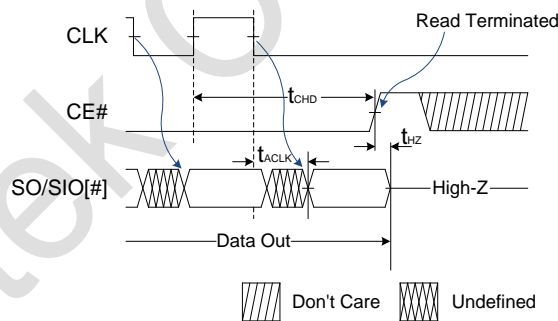

**Figure 3 : Read Command Termination**

## 11 WRAP BOUNDARY TOGGLE OPERATION

The Wrap Boundary Toggle Operation switches the device's wrapped boundary between Linear Burst which crosses the 1K page boundary (CA[9:0]) and wrap 32 (CA[4:0]) bytes. Default setting is Linear Burst.

Linear Burst allows the device to burst through page boundary. Page boundary crossing is invisible to the memory controller and limited to lower max CLK frequency of 84MHz. Table 3 shows an example of the sequence of bytes.

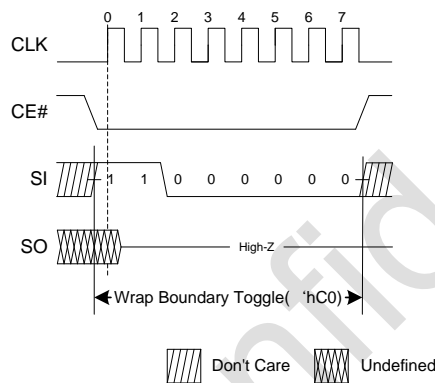

Figure 4 : SPI Wrap Boundary Toggle 'hC0

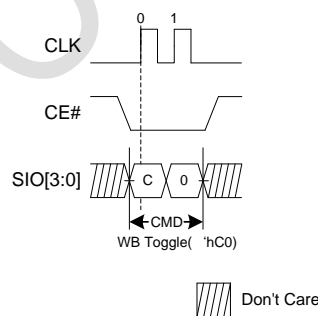

Figure 5 : QPI Wrap Boundary Toggle 'hC0

Table 3: Burst Type / Length

Burst Type / Length	Starting Address	Byte Sequence
Linear Burst	4	[4,5,6,...1023,1024,1025,1026,...]
Wrap 32	4	[4,5,6,...31,0,1,2,...]

## 12 SPI MODE OPERATIONS

The device powers up into SPI mode by default but can also be switched into QPI mode.

### 12.1 SPI Read Operations

For all reads, data will be available  $t_{\text{ACLK}}$  after the falling edge of CLK.

SPI Reads can be done in three ways:

1. 'h03: Serial CMD, Serial I/O, slow frequency, with linear or burst wrap of 32 byte configurability.
2. 'h0B: Serial CMD, Serial I/O, fast frequency, with burst wrap of 32/1K byte configurability.
3. 'hEB: Serial CMD, Quad I/O, fast frequency, with burst wrap of 32/1K byte configurability.

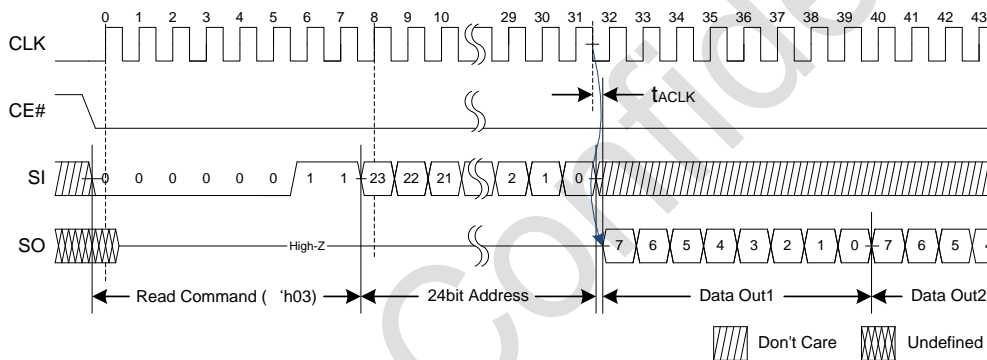

**Figure 6 : SPI Read 'h03 (MAX. freq. 33MHz)**

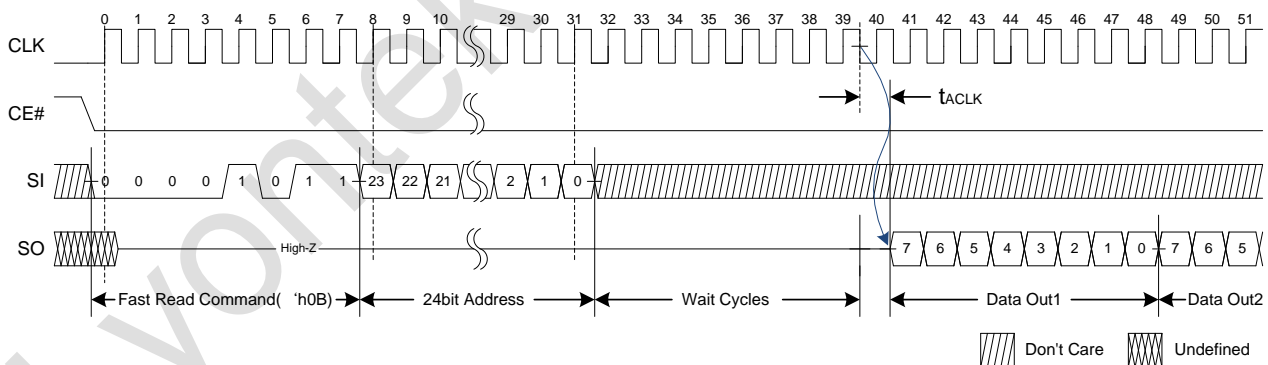

**Figure 7 : SPI Fast Read 'h0B (MAX. freq. 104MHz)**

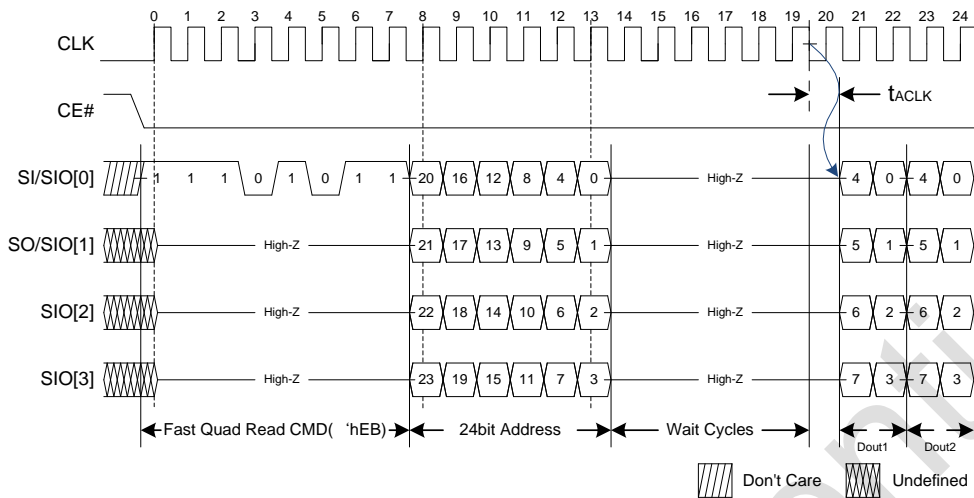

Figure 8 : SPI Fast Quad Read 'hEB (MAX. freq. 144MHz)

## 12.2 SPI Write Operations

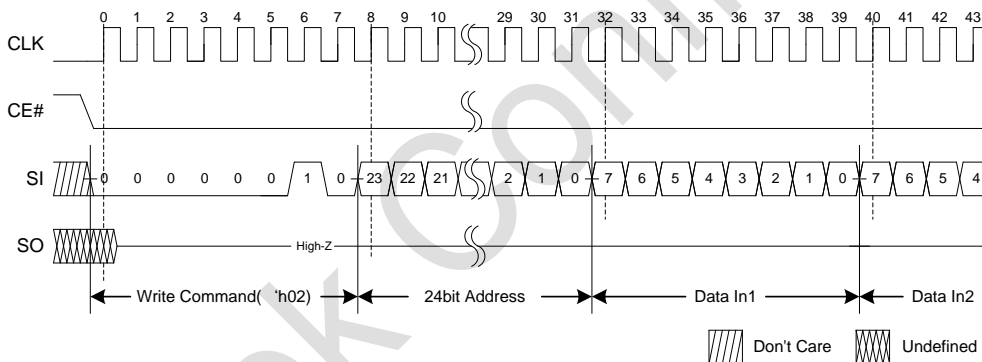

Figure 9 : SPI Write 'h02

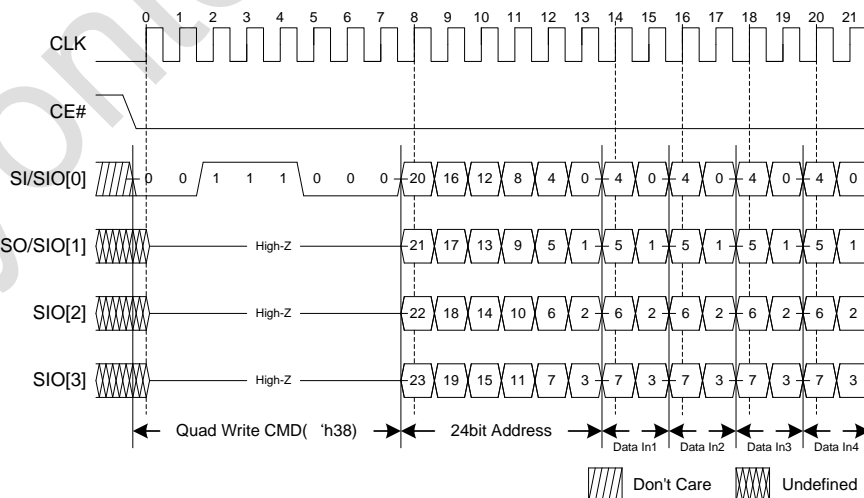
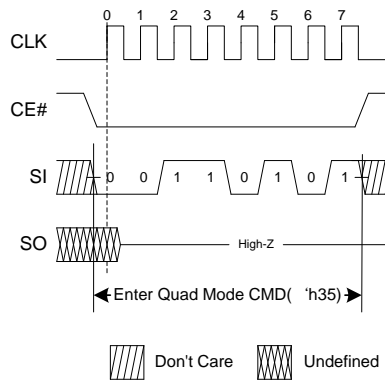

Figure 10 : SPI Quad Write 'h38

### 12.3 SPI Quad Mode Enable Operation

This command switches the device into quad I/O mode.



**Figure 11 : Quad Mode Enable 'h35**  
(available only in SPI mode)

### 12.4 SPI Read ID Operation

This command is similar to Fast Read, but without the wait cycles and the device outputs EID value instead of data.

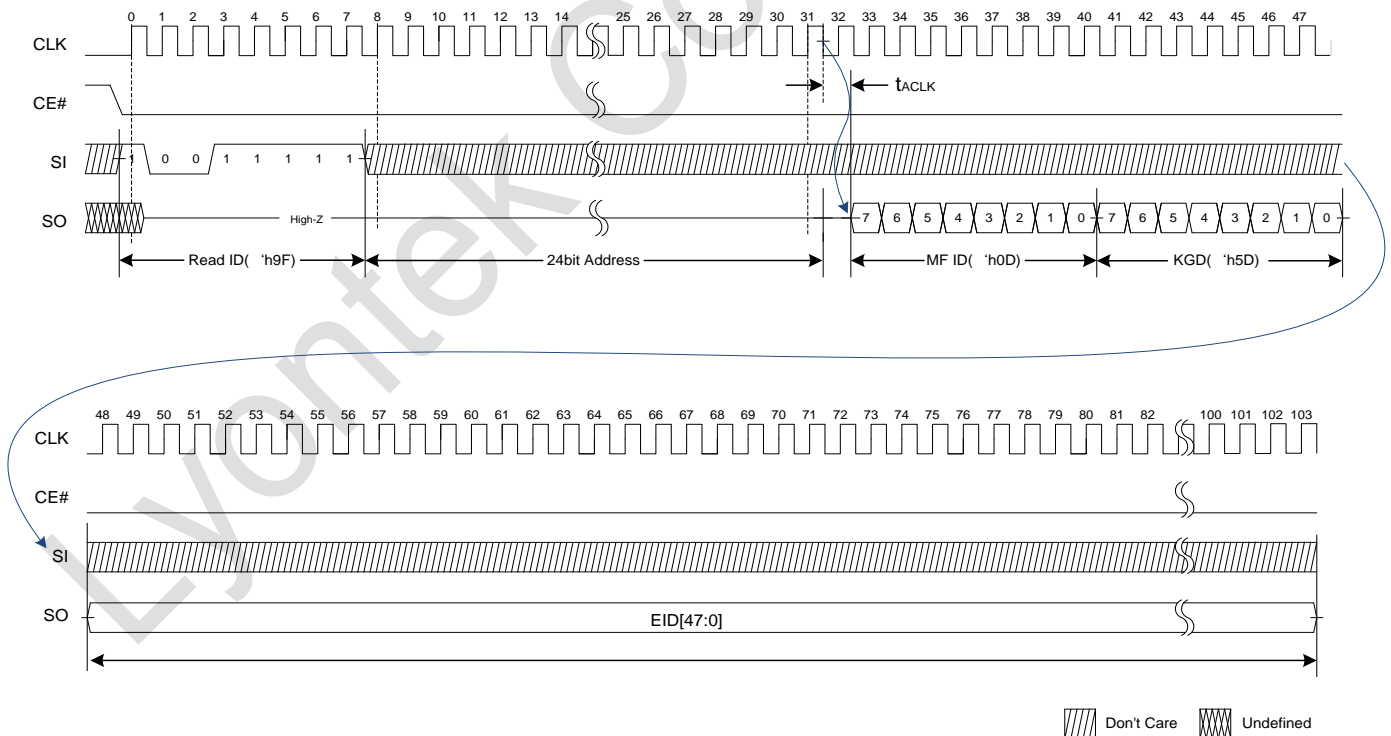

**Figure 12 : SPI Read ID 'h9F** (available only in SPI mode)



**Table 4: Known Good Die (KGD)**

KGD[7:0]	Known Good Die
'b0101_0101	FAIL
'b0101_1101	PASS

\*Note: Default is FAIL die, and only mark PASS after all tests passed.

**13 QPI MODE OPERATIONS**

**13.1 QPI Read Operations**

For all reads, data will be available  $t_{ACLK}$  after the falling edge of CLK.

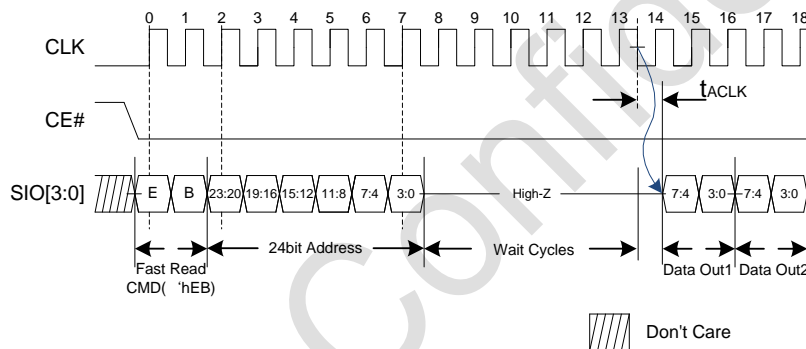

**Figure 13 : QPI Fast Read 'hEB (MAX. freq. 144MHz)**

**13.2 QPI Write Operation(s)**

QPI write command can be input as 'h02 or 'h38.

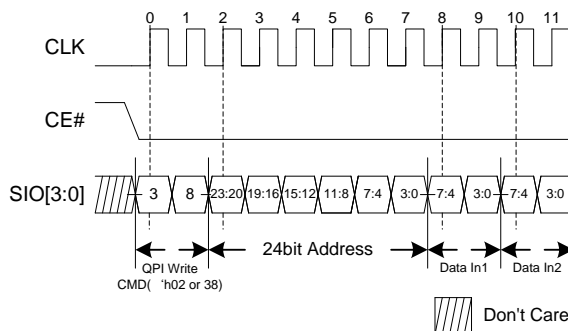

**Figure 14 : QPI Write 'h02 or 'h38**

### 13.3 QPI Quad Mode Exit Operation

This command will switch the device back into serial I/O mode.

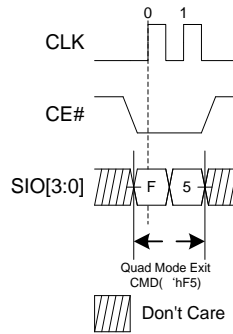

**Figure 15 : Quad Mode Exit 'hF5**  
(only available in QPI mode)



## 14 RESET OPERATION

The Reset operation is used as a system (software) reset that puts the device in SPI standby mode which is also the default mode after power-up. This operation consists of two commands: Reset-Enable (RSTEN) and Reset (RST).

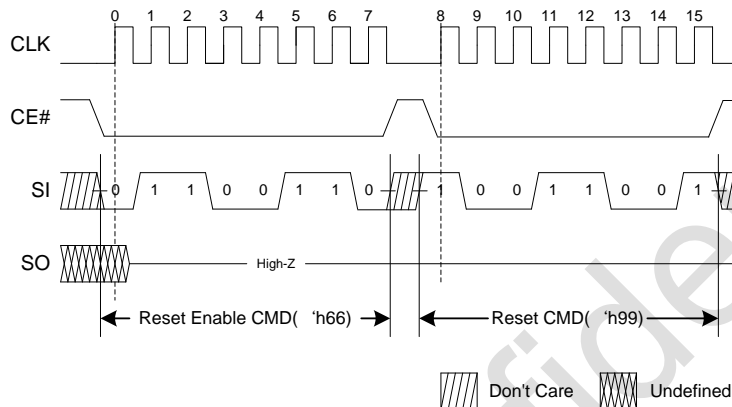

Figure 16 : SPI Reset

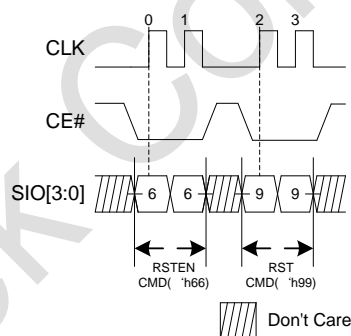

Figure 17 : QPI Reset

Reset command has to immediately follow the Reset-Enable command in order for the reset operation to take effect. Any command other than the Reset command after the Reset-Enable command will cause the device to exit Reset-Enable state and abandon reset operation.

### 15 INPUT / OUTPUT TIMING

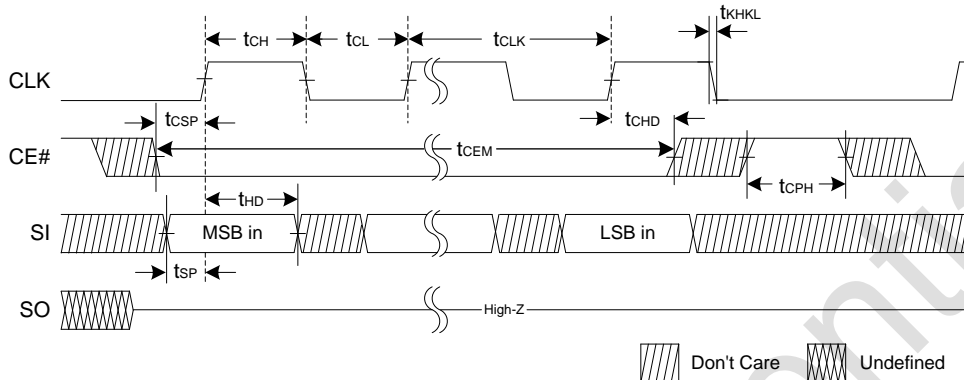

Figure 18 : Input Timing

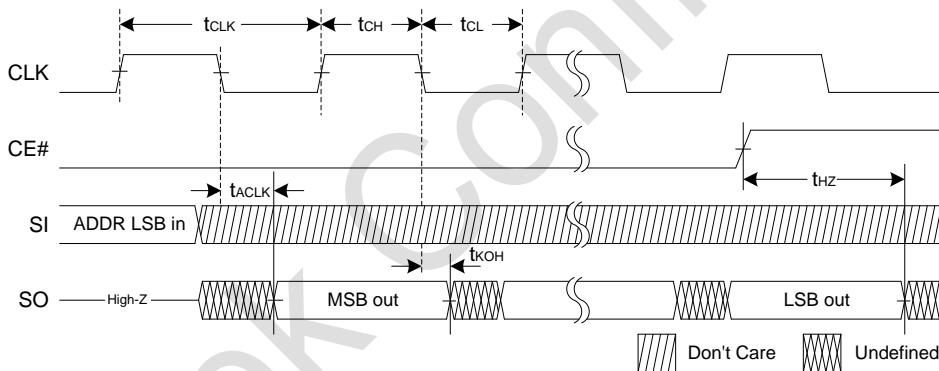

Figure 19 : Output Timing



## 16 ELECTRICAL SPECIFICATIONS

### 16.1 Absolute Maximum Ratings\*

Table 5: Absolute Maximum Ratings\*

PARAMETER	SYMBOL	RATING	UNIT	NOTES
Voltage to any pad except V <sub>CC</sub> relative to V <sub>SS</sub>	V <sub>T</sub>	-0.3 to V <sub>CC</sub> +0.3	V	
Voltage on V <sub>CC</sub> supply relative to V <sub>SS</sub>	V <sub>CC</sub>	-0.2 to +4.2	V	
Storage Temperature	T <sub>STG</sub>	-55 to +150	°C	1

Note: 1. Storage temperature refers to the case surface temperature on the center/top side of the PSRAM.

\* Exposing the device to stress above those listed in Absolute Maximum Ratings could cause permanent damage. The device is not meant to be operated under conditions outside the limits described in the operational section of this specification. Exposure to Absolute Maximum Rating conditions for extended periods may affect device reliability.

### 16.2 Pin Capacitance

Table 6: Package Pin Capacitance

PARAMETER	SYMBOL	MIN.	MAX.	UNIT	NOTES
Input Pin Capacitance	C <sub>IN</sub>	-	6	pF	V <sub>IN</sub> =0V
Output Pin Capacitance	C <sub>OUT</sub>	-	8	pF	V <sub>OUT</sub> =0V

Note: 1. Spec'd at 25°C.

### 16.3 Operating Conditions

Table 7: Operating Characteristics

PARAMETER	MIN.	MAX.	UNIT
Operating Temperature	-40	85	°C

## 16.4 DC Electrical Characteristics

**Table 8: DC Characteristics**

SYMBOL	PARAMETER	MIN.	MAX.	UNIT	NOTES
V <sub>CC</sub>	Supply Voltage	2.7	3.6	V	
V <sub>IH</sub>	Input high voltage	V <sub>CC</sub> -0.4	V <sub>CC</sub> +0.2	V	
V <sub>IL</sub>	Input low voltage	-0.2	0.4	V	
V <sub>OH</sub>	Output high voltage (I <sub>OH</sub> =-0.2mA)	0.8 V <sub>CC</sub>	-	V	
V <sub>OL</sub>	Output low voltage (I <sub>OL</sub> =+0.2mA)	-	0.2 V <sub>CC</sub>	V	
I <sub>LI</sub>	Input leakage current	-	1	μA	
I <sub>LO</sub>	Output leakage current	-	1	μA	
I <sub>CC</sub>	Read/Write	-	40	mA	
I <sub>SB</sub>	Standby current	-	400	μA	1

Note: 1. Standby current is measured when CLK is in DC low state.

## 16.5 AC Electrical Characteristics

**Table 9: READ/WRITE Timing**

SYMBOL	PARAMETER	MIN.	MAX.	UNIT	NOTES
t <sub>CLK</sub>	CLK period - SPI Read ('h03)	30.3	-	ns	33MHz
	CLK period – all other operations	7	-		144MHz <sup>*1,2</sup>
t <sub>CH</sub> / t <sub>CL</sub>	Clock high/low width	0.45	0.55	t <sub>CLK</sub> (min)	
t <sub>KHKL</sub>	CLK rise or fall time	-	1.5	ns	
t <sub>CPH</sub>	CE# HIGH between subsequent burst operations	50	-	ns	
t <sub>GEM</sub>	CE# low pulse width	-	8	μs	
t <sub>CSP</sub>	CE# setup time to CLK rising edge	2.5	-	ns	
t <sub>CHD</sub>	CE# hold time from CLK rising edge	20	-	ns	
t <sub>SP</sub>	Setup time to active CLK edge	2	-	ns	
t <sub>HD</sub>	Hold time from active CLK edge	2	-	ns	
t <sub>HZ</sub>	Chip disable to DQ output high-Z	-	6	ns	
t <sub>ACLK</sub>	CLK to output delay	2	6	ns	
t <sub>KOH</sub>	Data hold time from clock falling edge	1.5	-	ns	

Note: 1. Only Linear Burst allows page boundary crossing. Frequency limits are therefore 144MHz MAX. without crossing page boundary, and 84MHz MAX. when burst commands cross page boundary.

2. For operating frequencies > 84MHz, refer to JEDEC JESD84-B50 for data sampling training.



THIS PAGE IS LEFT BLANK INTENTIONALLY.

Lyontek Confidential

## X-ON Electronics

Largest Supplier of Electrical and Electronic Components

*Click to view similar products for [SRAM](#) category:*

*Click to view products by [Lyontek](#) manufacturer:*

Other Similar products are found below :

[CY6116A-35DMB](#) [CY7C1049GN-10VXI](#) [CY7C1461KV33-133AXI](#) [GS8161Z36DD-200I](#) [GS88237CB-200I](#) [RMLV0408EGSB-4S2#AA0](#)  
[IS64WV3216BLL-15CTLA3](#) [IS66WVE4M16ECLL-70BLI](#) [PCF8570P](#) [K6F2008V2E-LF70000](#) [K6T4008C1B-GB70](#) [CY7C1353S-100AXC](#)  
[AS6C8016-55BIN](#) [AS7C164A-15PCN](#) [515712X](#) [IS62WV51216EBLL-45BLI](#) [IS63WV1288DBLL-10HLI](#) [IS66WVE2M16ECLL-70BLI](#)  
[70V639S10BCG](#) [IS66WVE4M16EALL-70BLI](#) [IS61WV102416DBLL-10TLI](#) [CY7C1381KV33-100AXC](#) [CY7C1460KV25-200BZI](#)  
[CY7C1373KV33-100AXC](#) [CY7C1381KVE33-133AXI](#) [CY7C4121KV13-600FCXC](#) [GS882Z18CD-150I](#) [IS61WV102416DBLL-10BLI](#)  
[IS66WVC2M16ECLL-7010BLI](#) [7140LA35PDG](#) [CY7C1380KV33-250AXC](#) [AS6C8016-55BINTR](#) [CY7C1370KV33-250AXC](#)  
[CY7C1370KVE33-167AXI](#) [AS7C34096B-10TIN](#) [AS6C8016-55TIN](#) [IS62WV25616EALL-55TLI](#) [GS8128418B-167IV](#) [CY7C1460KV25-](#)  
[200BZXI](#) [CY7C1460KV25-167BZXI](#) [CY7C1315KV18-333BZXC](#) [CY7C1370KV25-200AXC](#) [71421LA55JI8](#) [CY62158G30-45ZSXI](#)  
[CY62157G30-45ZSXI](#) [RMLV3216AGSD-5S2#AA0](#) [CY62187G30-55BAXI](#) [CY62157G30-45ZXI](#) [71V016SA20YGI](#) [71V124SA15YGI8](#)