

Core2 v1.1

SKU:K010-V11



Description

Core2 V1.1 is an iterative version of Core, with upgraded power IC and a continuation of the classic design of Core2. It is a powerful and user-friendly development board. Core2 V1.1 is equipped with ESP32-D0WDQ6-V3, featuring two independent Xtensa® 32-bit LX6 processors with a clock frequency of up to 240MHz. It supports WiFi functionality and has onboard 16MB Flash and 8MB PSRAM, and supports program downloading via the TYPE-C interface. Its strong configuration can meet the requirements of complex applications.

Core2 V1.1 is equipped with a 2.0-inch integrated capacitive touch screen. The three dots on the front of the screen are part of the touch screen. Users can set the hot zone mapping as three virtual buttons through programming, enabling diverse human-machine interaction experiences. Additionally, Core2 V1.1 has a built-in vibration motor for haptic feedback and vibration alert functionality.

Core2 V1.1 has an integrated RTC module and a dedicated battery for RTC power supply, providing accurate timing functionality. Furthermore, the AXP2101 power management chip effectively controls the power consumption of the device. Core2 V1.1 also has a built-in blue power indicator light, which can be used to implement specific functions or status indications according to the user's application needs. Core2 V1.1 is also equipped with a MicroSD card slot, speaker, and a high-quality I2S digital audio interface power

amplifier chip. The expansion board on the back of the device integrates a 6-axis IMU sensor and a microphone, providing additional functionality and possibilities.

The differences between Core2 and Core2 v1.1 are as follows:

- 1.The power management scheme is iterated from Core2(AXP192) to Core2 v1.1(AXP2101+INA3221). The ID of AXP192 and AXP2101 is different, and the program uses this as a sign to distinguish the versions;
- 2.The power indicator is changed from green to blue;
- 3.Add RTC chip power supply battery to ensure accurate timing when power is off.

Power Management

Operations:

Power on: One click the power button on the left

Power off: Long press the left power button for 6 seconds

Reset: Click the RST button on the bottom side

USB drive

Before using, please go to [download page](#) to download the USB driver that matches your operating system, and install it.

Note: **Core2** currently has two CH9102F A USB chip version, users can install the drivers (**CH9102**) that are compatible with two ICs at the same time to ensure that the device drivers work normally.

Extensions

To stack Core2 V1.1 with M5 modules, you need to remove/eliminate the battery bottom of Core2 V1.1; If you wish to keep I2S Mic, IMU and Battery functions, a [M5GO Bottom2](#) is required.

The vibration sensor of Core2 V1.1 and M5 Base series are incompatible in mechanical design. Please do not stack them together.

Some of the screen edges will have touch non-linearity problem, you can try to use [M5Tool](#) to upgrade the screen firmware to solve this problem.

This product contains batteries that are non-replaceable.

Tutorial

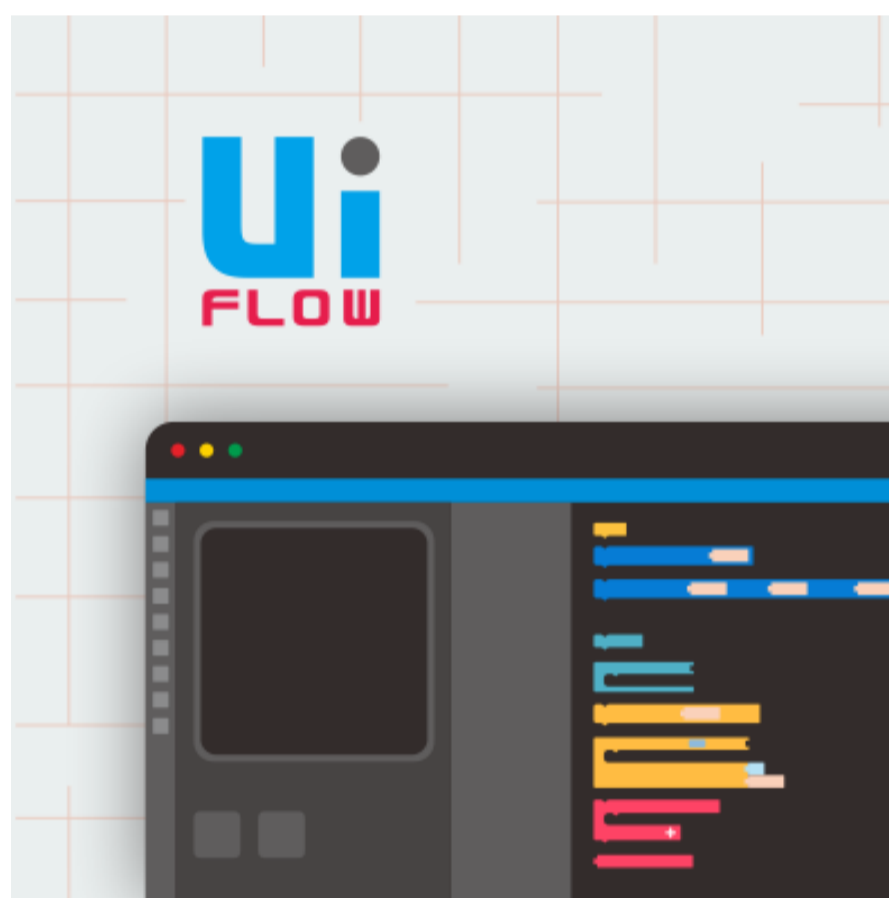

UIFlow

This tutorial will show you how to control Core2 v1.1 devices through the UIFlow graphical programming platform



Arduino IDE

This tutorial will show you how to program and control Core2 v1.1 devices through Arduino IDE

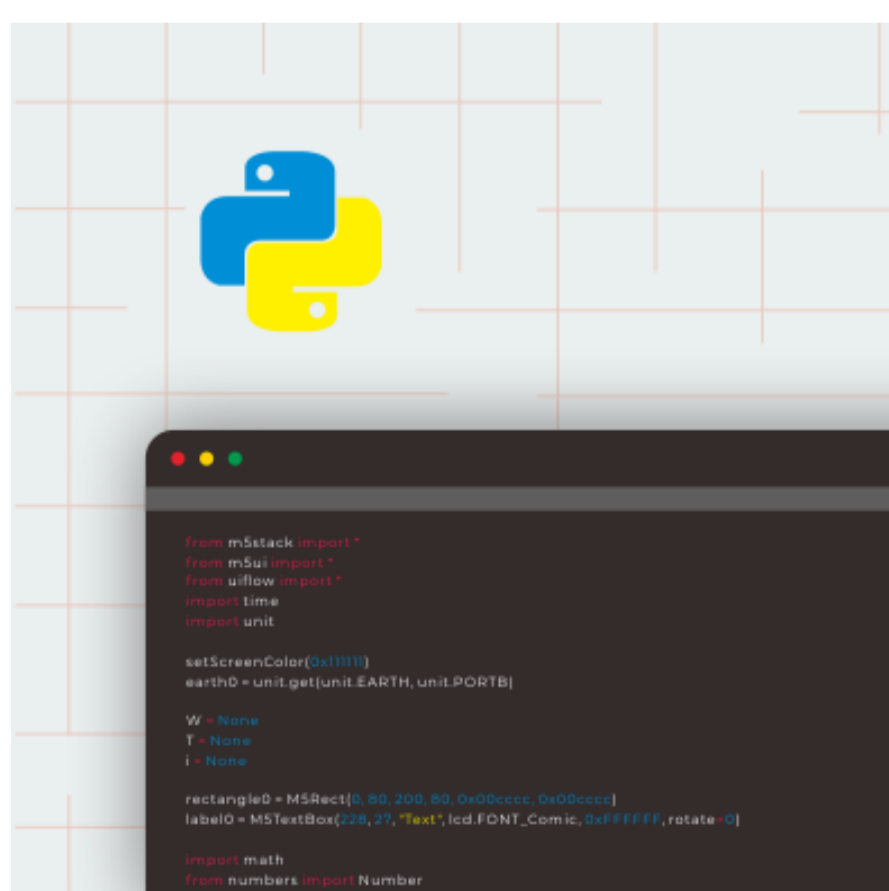

Micropython

This tutorial will show you how to control Core2 v1.1 devices through Micropython programming

Features

- ESP32-based, built-in Wi-Fi
- 16M Flash, 8M PSRAM

- Built-in speaker, power indicator, vibration motor, RTC, I2S amplifier, capacitive touch screen, power button, reset button
- TF card slot (16G Maximum size)
- Built-in lithium battery, equipped with power management chip
- Independent small board built-in 6-axis IMU, PDM microphone
- M-Bus Socket & Pins
- Compatible with multi-platform development:
 - UIFlow
 - MicroPython
 - Arduino
 - .NET nanoFramework
 - Operating System (RTOS):zephyr

| Includes

- 1x Core2 V1.1
- 1x Type-C USB(20cm)
- 1x HEX KEY

| Applications

- Internet of things terminal controller
- Stem education product
- DIY creation
- Smart home equipment

| Specification

Resources	Parameters
ESP32-D0WDQ6-V3	240MHz dual core, 600 DMIPS, 520KB SRAM, Wi-Fi
Flash	16MB
PSRAM	8MB
Input Voltage	5V @ 500mA

Interface	TypeC x 1, GROVE(I2C+I/O+UART) x 1
IPS LCD Screen	2.0"@320*240 ILI9342C
Touch Screen	FT6336U
Speaker	1W(SIZE:0928)
LED	Green power indicator light
Button	Power button, RST button, Virtual screen button*3
Vibration reminder	Vibration motor
MIC	SPM1423
I2S Power Amplifier	NS4168
6-axis IMU	MPU6886
RTC	BM8563
PMU	AXP2101
Current Meter	INA3221
USB Chip	CH9102F
DC-DC Boost	SY7088
TF card slot	16G Max
Lithium Battery	500mAh @ 3.7V
Antenna	2.4G 3D antenna
Operating temperature	0°C to 60°C
Base screw specifications	Hexagon socket countersunk head M3
Internal PCB board reserved interface	Battery interface (specification: 1.25mm-2P) USB line interface (specification: 1.25mm-4P)
Case Material	Plastic (PC)
Product Size	54 x 54 x 16.5mm

Package Size	75 x 60 x 20mm
Product Weight	54.8g
Package Weight	83.9g

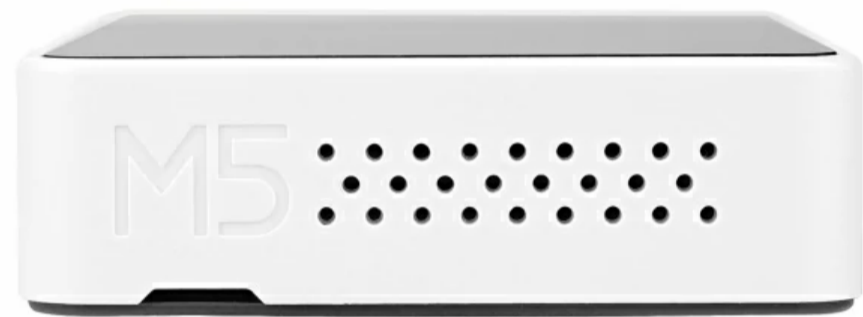

Products related to this item

[CORE2 \(K010\)](#)

[BASIC-V27 \(K001-V27\)](#)

[CoreS3 \(K128\)](#)

[Steptomotor Driver Module13.2 v1.1 \(M039-V11\)](#)

[TOF \(U010\)](#)

Related Link

- [ESP32](#)
- [FT6336U](#)
- [NS4168](#)
- [MPU6886](#)
- [ILI9342C](#)
- [SPM1423](#)
- [BM8563](#)

- SY7088
- AXP2101
- 1027DC Motor
- INA3221

Schematic

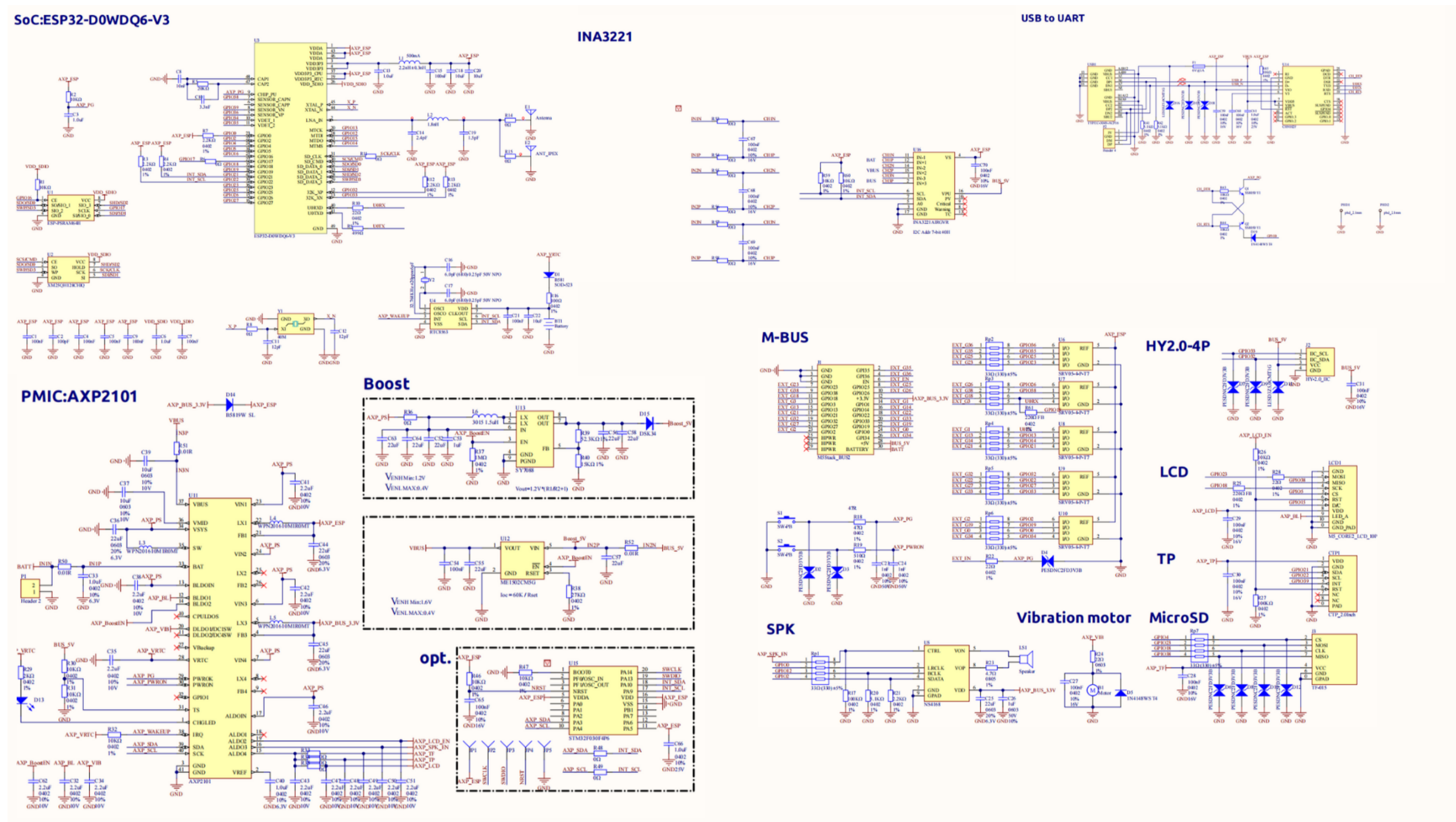

- [Complete schematic pdf](#)

EasyLoader

- **Windows**
 - [EasyLoader_Core2_v1.1_FactoryTest](#)

PinMap

LCD & TF card(LCD :320x240 TF card Maximum size 16GB)

ESP32	GPIO3	GPIO2	GPIO1	GPIO5	GPIO1	
Chip	8	3	8	5		
AXP210						AXP_AL
1 Chip						DO2

ILI9342	MISO	MOSI	SCK	CS	DC	RST
ESP32 Chip	GPIO38	GPIO23	GPIO18	GPIO4		
TF Card	MISO	MOSI	SCK	CS		

CAP.TOUCH (I2C Addr: 0x38)

ESP32 chip	GPIO21	GPIO22	GPIO39	
AXP2101				AXP_ALDO2
FT6336U	SDA	SCL	INT	RST

Mic & NS4168(Speaker)

ESP32 Chip	GPIO12	GPIO0	GPIO2	AXP_ALDO3	GPIO34
NS4168	BCLK	LRCK	DATA	SPK_EN	
Mic		CLK			DATA

AXP Power Indicator Light

AXP2101	VRTC	DLDO1
Bule LED	Vcc	
Vibration motor		Vcc

RTC

ESP32 Chip	GPIO21	GPIO22	
AXP2101			AXP_IRQ
BM8563	SDA	SCL	INT

IMU(3-axis gyroscope & 3-axis accelerometer)

ESP32 Chip	GPIO21	GPIO22
MPU6886	SDA	SCL

USB to serial chip

ESP32 Chip	GPIO1	GPIO3
CH9102F	RXD	TXD

Internal I2C connection

ESP32 Chip	GPIO21	GPIO22
MPU6886	SDA	SCL
AXP2101	SDA	SCL
BM8563	SDA	SCL
FT6336U	SDA	SCL
INA3221	SDA	SCL

M5PORT DEFINE

PORT	PIN	NOTE:
PORT-A(Red)	G32/33	I2C
PORT-B(Black)	G26/36	DAC/ADC
PORT-C(Bule)	G13/14	UART

ESP32 ADC/DAC(For more information about Pin assignment and Pin Remapping, Please refer to [ESP32 Datasheet](#))

ADC1	ADC2	DAC1	DAC2
8 Channels	10 Channels	2 Channels	2 Channels
G32-39	G0/2/4/12-15/25-27	G25	G26

Core2 v1.1 M-BUS Schematic diagram

	GND	ADC	G35
	GND	ADC	G36
	GND	RST	EN
G23	MOSI	DAC	G25
G38	MISO	DAC	G26
G18	SCK	3.3V	
G3	RXD0	TXD0	G1
G13	RXD2	TXD2	G14
G21	intSDA	intSCL	G22
G32	PA_SDA	PA_SCL	G33
G27	GPIO	GPIO	G19
G2	I2S_DOUT	I2S_LRCK PDM_CLK	G0
	NC	PDM_DAT	G34
	NC	5V	
	NC	BAT	

Core2 v1.1 BUS(compared to M5Stack)

| Module Size

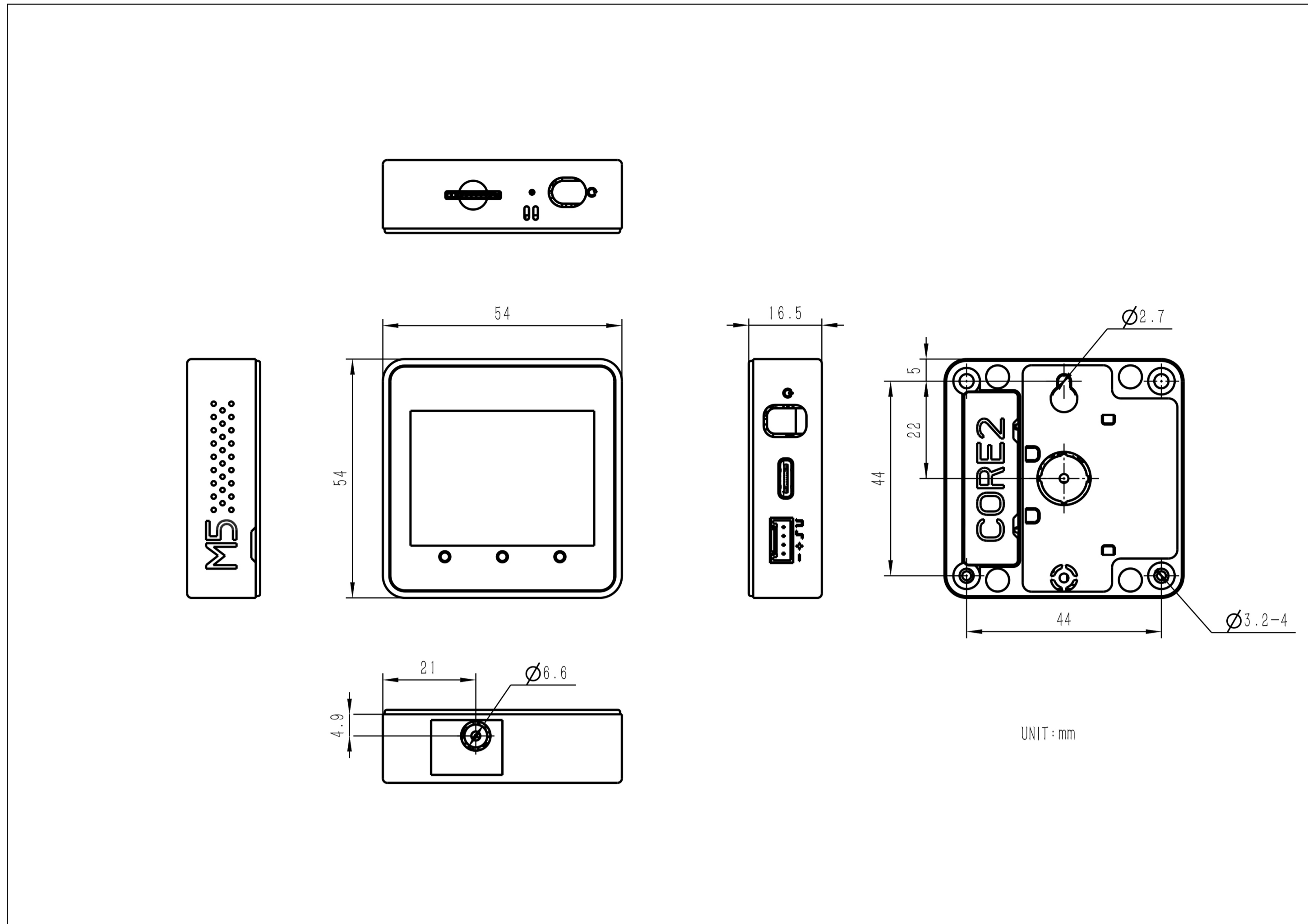

Examples

Arduino

- [Arduino API](#)
- [Graphics driver library file](#)
- [Peripheral driver file](#)

Video

- This case will perform hardware running tests for speakers, wifi, buttons, accelerometer, TF-card(microSD), screen, etc.

Version Change

Release Date	Product Changes	Notes
/	First ReleaseCor	/

Release Date	Product Changes	Notes
	e2	
2023.11	Core2 v1.1	Change PMU power management chip to AXP2101+INA3221/ Add RTC power battery/The power indicator changes to blue

Comparison of AXP2101(Core2 v1.1) and AXP192(Core2) parameters

Peculiarity	AXP2101 (Core2 v1.1)	AXP192 (Core2)
Battery voltage	0.7V - 4.2V	0.7V - 4.2V
Battery charging current	100mA	500mA
Battery charging efficiency	94%	90%
Battery charging termination current	10mA	50mA
Battery discharge efficiency	96%	95%
Supply output current	300mA	500mA
Power output efficiency	95%	90%

FAQ

Q: If the memory card fails to read, you can add the following code in the initialization to increase the host memory card reading ability.

A:

```
for (auto gpio : (const uint8_t[]){18, 19, 23}) {
    *(volatile uint32_t*)(GPIO_PIN_MUX_REG[gpio]) |= FUN_DRV_M;
    gpio_pulldown_dis((gpio_num_t)gpio);
    gpio_pullup_en((gpio_num_t)gpio);
}
```

```
1 #include <SPI.h>
2 #include <SD.h>
3
4 #include <soc/gpio_reg.h>
5 #include <soc/io_mux_reg.h>
6
7 void setup() {
8     SPI.begin(18, 19, 23);
9
10    // // 对策代码从这里开始
11    for (auto gpio : (const uint8_t[]){18, 19, 23}) {
12        *(volatile uint32_t*)(GPIO_PIN_MUX_REG[gpio]) |= FUN_DRV_M;
13        gpio_pullup_dis((gpio_num_t)gpio);
14        gpio_pullup_en((gpio_num_t)gpio);
15    }
16    // // 对策代码到此结束
17
18    Serial.begin(115200);
19    Serial.println("SD begin.\n");
20
21    while (!SD.begin(4, SPI, 1000)) {
22        delay(1024);
23        Serial.println(".\n");
24    }
25
26    Serial.println("SD done.\n");
27 }
28
29 void loop() {
30     delay(1);
31 }
```

Learn



Health monitor - Waylay IO

Health monitoring using the M5Stack Mini Heart Rate Unit and Non-Contact Infrared Thermometer Unit and the Waylay IO IoT platform.

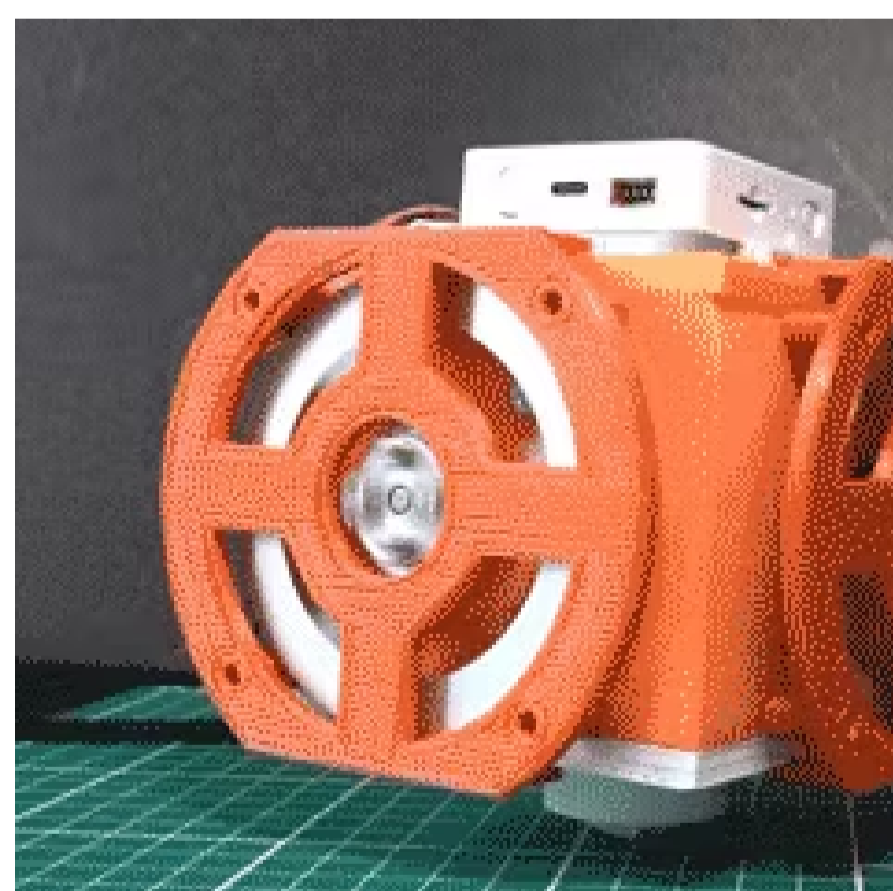

One-Wheel Balancing Robot Using Reaction Wheels

I made one-wheel balancing robot. This robot can be operated remotely from a smartphone using Blynk.



M5Stack Christmas Snow Globe

Modern times make modern solutions possible. Therefore, the step to a digital snow globe is not that far.



Simple remote for home automatization with Core 2 (wip)

Developing a simple remote for my openhub, I have got the app but do not want to unlock my phone, open the app to do stuff

X-ON Electronics

Largest Supplier of Electrical and Electronic Components

Click to view similar products for [Development Boards & Kits - Other Processors](#) category:

Click to view products by [M5Stack](#) manufacturer:

Other Similar products are found below :

[KIT_AURIX_TC233LP_TRB](#) [STM8S/32-D/RAIS](#) [QB-R5F110PJ-TB](#) [ST7MDT1-EMU2](#) [KITA2GTC3975VTRBSTOBO1](#)
[RTK5572TKCS00000BE](#) [ST623X-KIT/220](#) [STEVAL-ISV014V1](#) [KIT_XC836_EK_V1](#) [XIAO STARTER KIT](#) [SIBRAIN FOR](#)
[AVR128DA64](#) [CLICKER 4 FOR TMPM3H](#) [ACRYLIC CASE FOR XIAO EXPANSION BOARD](#) [RSSDEMO50F-AA-13# DEMO KIT](#) [VS](#)
[1000 DEMO BOARD](#) [SIBRAIN FOR AVR64DA64](#) [XIAO RP2040](#) [GSM CLICK](#) [CODEGRIP ADAPT V6](#) [DUAL SMART USB CHARGER](#)
[WIZFI360-EVB-PICO](#) [EDGE CONTROL ENCLOSURE KIT](#) [DK-SOC-10AS066S-E](#) [902-0183-000](#) [Y-ASK-RL78F13-V2](#) [Y-ASK-](#)
[RL78F14-V2](#) [Y-ASK-RL78F15-V2](#) [KITA2GTC3895VTRBTOBO1](#) [KITA2GTC3995VTRBTOBO1](#) [CONNECTEVE](#) [R0K521380S000BE](#)
[R0K578L1CD000BR](#) [LV-24-33 V6 44-PIN TQFP MCU CARD EMPTY](#) [LV-24-33 V6 64-PIN TQFP MCU CARD EMPTY](#) [LV-24-33 V6 80-](#)
[PIN TQFP 1 MCU CARD EMPTY](#) [32X32 RGB LED MATRIX PANEL - 6MM PITCH](#) [READY FOR XMEGA CASING \(WHITE\)](#) [RELAY4](#)
[BOARD](#) [ETHERNET CONNECTOR](#) [RFID CARD 125KHZ - TAG](#) [RFM12B-DEMO](#) [MAROON](#) [MAX232](#) [MAX3232 BOARD](#) [THREE-](#)
[AXIS ACCELEROMETER BOARD](#) [TINKERKIT HALL SENSOR](#) [TOUCHPANEL CONTROLLER](#) [MIKROBOARD FOR AVR WITH](#)
[ATMEGA128](#) [MIKROBUS CAPE](#) [MIKROETH 100 BOARD](#)