

Features

- Attenuation: 16.0 dB Steps to 32 dB
- Low DC Power Consumption
- Hermetic Surface Mount Package
- Integral TTL Driver
- 50 ohm Impedance
- Temperature Stability: ± 0.18 dB from -55°C to $+85^{\circ}\text{C}$ Typ.
- Tape and Reel Packaging Available
- Lead-Free CR-11 Package
- 260°C Reflow Compatible
- RoHS* Compliant

Description

M/A-COM's AT-273-PIN is a GaAs FET digital attenuator with a 16.0 dB minimum step size and a 32 dB total attenuation range. This attenuator and integral TTL driver is in a hermetically sealed ceramic 16-lead surface mount package. The AT-273-PIN is ideally suited for use where accuracy, fast switching, very low power consumption and low intermodulation products are required. Typical applications include dynamic range setting in precision receiver circuits and other gain/leveling control circuits. Environmental screening is available. Contact the factory for information.

Functional Schematic¹

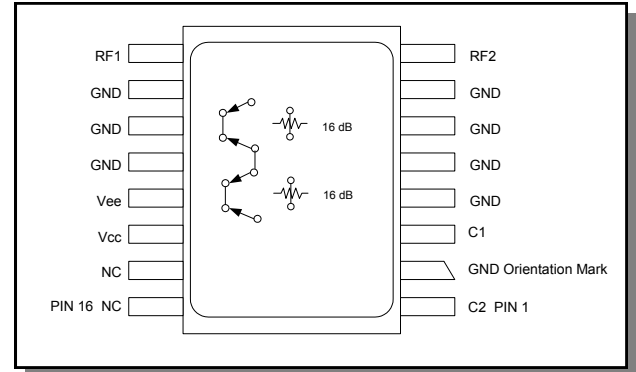

1. Use the C1 control for a single 16-dB bit.

Pin Configuration

Pin No.	Function	Pin No.	Function
1	C2	9	RF1
2	GND	10	GND
3	C1	11	GND
4	GND	12	GND
5	GND	13	Vee
6	GND	14	Vcc
7	GND	15	NC
8	RF2	16	NC

The metal bottom of the case must be connected to RF and DC ground.

Ordering Information

Part Number	Package
AT-273-PIN	Bulk Packaging

Note: Reference Application Note M513 for reel size information.

¹ * Restrictions on Hazardous Substances, European Union Directive 2002/95/EC.

Digital Attenuator 32.0 dB, 2-Bit, TTL Driver, DC-2.0 GHz

Rev. V9

Electrical Specifications: $T_A = 25^\circ\text{C}^{1,2}$

Parameter	Test Conditions	Frequency	Units	Min	Typ	Max
Insertion Loss	—	DC - 0.5 GHz	dB	—	—	1.6
		DC - 1.0 GHz	dB	—	—	1.7
		DC - 2.0 GHz	dB	—	—	1.9
Attenuation Accuracy	C1 Bit Full Attenuation (32 dB) Full Attenuation (32 dB) Full Attenuation (32 dB)	DC - 2.0 GHz DC - 0.5 GHz DC - 1.0 GHz DC - 2.0 GHz	$\pm 3\%$ of attenuation setting in dB $\pm 3\%$ of attenuation setting in dB $\pm 3\%$ of attenuation setting in dB, -1 dB $\pm 3\%$ of attenuation setting in dB, -3 dB			
VSWR	Full Range	DC - 2.0 GHz	Ratio	—	—	1.6:1
Trise, Tfall	10% to 90%	—	ns	—	7	—
Ton, Toff	50% Cntl to 90% / 10% RF	—	ns	—	28	—
Transients	In-Band (peak-to-peak)	—	mV	—	30	—
1 dB Compression	Input Power Input Power	0.05 GHz	dBm	—	+20	—
		0.5 - 2.0 GHz	dBm	—	+28	—
Input IP3	Two-tone inputs up to +5 dBm	0.05 GHz	dBm	—	+38	—
		0.5 - 2.0 GHz	dBm	—	+48	—
Input IP2	Two-tone inputs up to +5 dBm	0.05 GHz	dBm	—	+44	—
		0.5 - 2.0 GHz	dBm	—	+68	—
Vcc	—	—	V	4.5	5.0	5.5
-Vee	—	—	V	-8.0	—	-5.0
Vctl	Logic (0) TTL	—	V	0.0	—	0.8
Vctl	Logic (1) TTL	—	V	2.0	—	5.0
Input Leakage Current (Low) Input Leakage Current (High)	0 to 0.8V	—	μA	—	—	1.0
	2.0 to 5.0V	—	μA	—	—	1.0
Icc	Vcc = 4.5 to 5.5V Vctl = 0 to 0.8V, or Vcc -2.1V to Vcc	—	mA	—	—	2.0
-lee	Vee = -5.0 to -8.0V	—	mA	—	—	-1

1. All specifications apply when operated with bias voltages of +5V for Vcc and -5.0V for Vee.
2. This attenuator is guaranteed monotonic.

Absolute Maximum Ratings ^{3,4}

Parameter	Absolute Maximum
Max. Input Power 0.05 GHz 0.5 - 2.0 GHz	+27 dBm +34 dBm
V_{CC}	$-0.5V \leq V_{CC} \leq +7.0V$
V_{EE}	$-8.5V \leq V_{EE} \leq +0.5V$
$V_{CC} - V_{EE}$	$-0.5V \leq V_{CC} - V_{EE} \leq 14.5V$
V_{in}^5	$-0.5V \leq V_{in} \leq V_{CC} + 0.5V$
Operating Temperature	-55°C to +125°C
Storage Temperature	-65°C to +150°C

- Exceeding any one or combination of these limits may cause permanent damage to this device.
- M/A-COM does not recommend sustained operation near these survivability limits.
- Standard CMOS TTL interface, latch-up will occur if logic signal is applied prior to power supply.

Handling Procedures

Please observe the following precautions to avoid damage:

Static Sensitivity

Gallium Arsenide Integrated Circuits are sensitive to electrostatic discharge (ESD) and can be damaged by static electricity. Proper ESD control techniques should be used when handling these devices.

Truth Table (Digital Attenuator)

C1	C2	Attenuation
0	0	Loss, Reference
0	1	16.0 dB
1	1	32.0 dB

0 = TTL Low; 1 = TTL High

Typical Performance Curves

Ref. Insertion Loss vs. Frequency

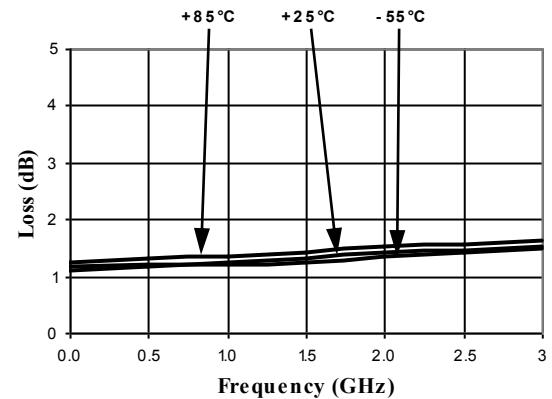

Attenuation Accuracy vs. Frequency

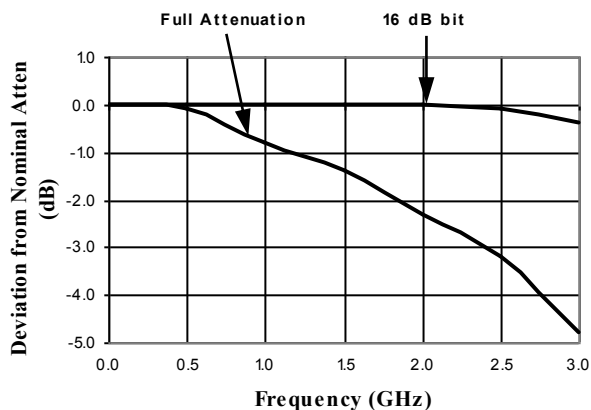

VSWR vs. Frequency

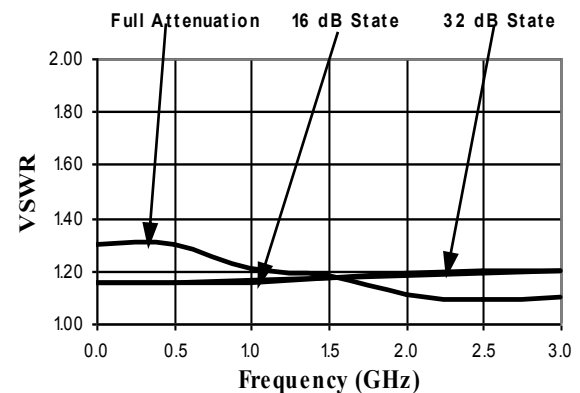

AT-273-PIN



Digital Attenuator
32.0 dB, 2-Bit, TTL Driver, DC-2.0 GHz

Rev. V9

Lead-Free, CR-11 Ceramic Package[†]

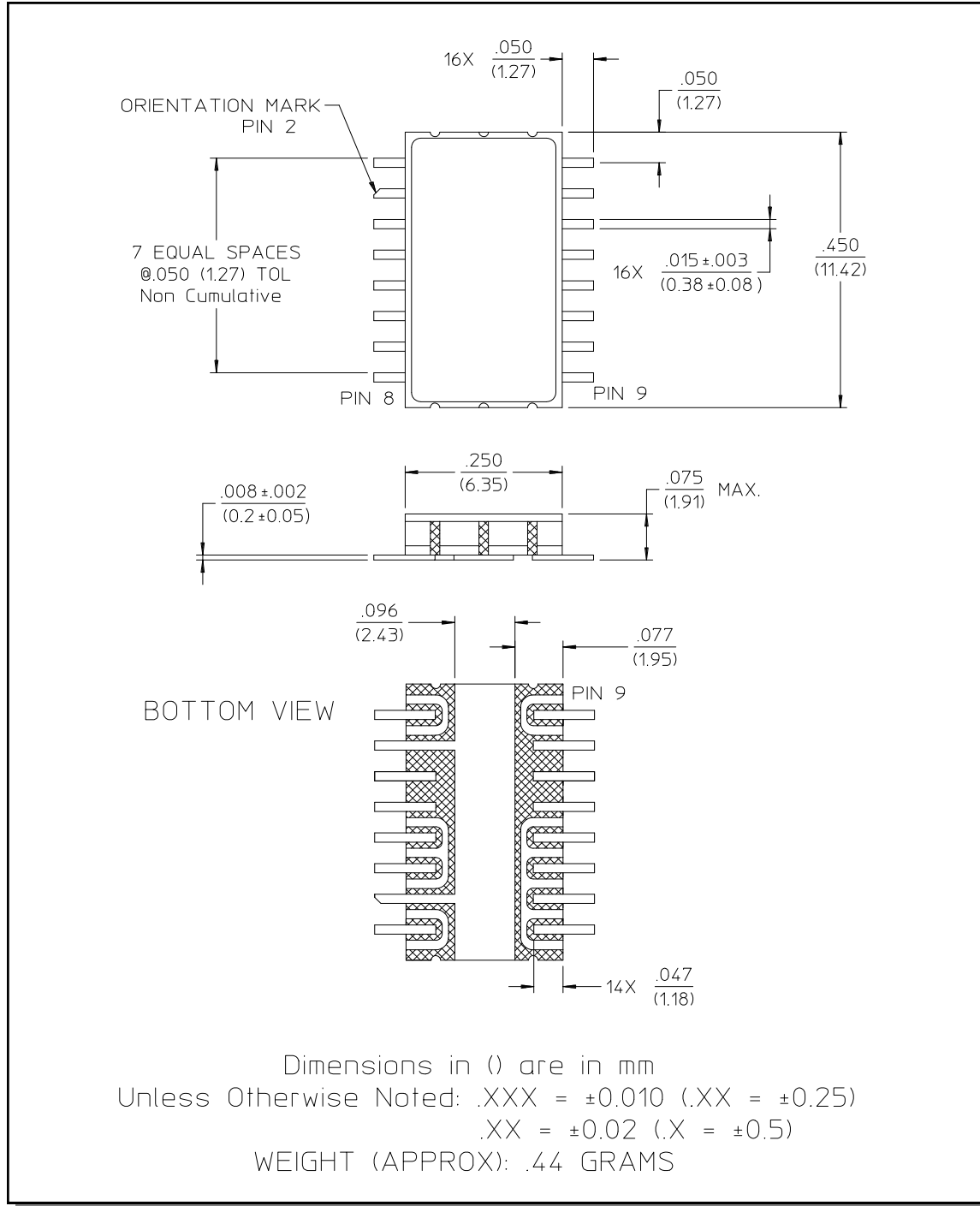

[†] Reference Application Note M538 for lead-free solder reflow recommendations.

M/A-COM Technology Solutions Inc. All rights reserved.

Information in this document is provided in connection with M/A-COM Technology Solutions Inc ("MACOM") products. These materials are provided by MACOM as a service to its customers and may be used for informational purposes only. Except as provided in MACOM's Terms and Conditions of Sale for such products or in any separate agreement related to this document, MACOM assumes no liability whatsoever. MACOM assumes no responsibility for errors or omissions in these materials. MACOM may make changes to specifications and product descriptions at any time, without notice. MACOM makes no commitment to update the information and shall have no responsibility whatsoever for conflicts or incompatibilities arising from future changes to its specifications and product descriptions. No license, express or implied, by estoppel or otherwise, to any intellectual property rights is granted by this document.

THESE MATERIALS ARE PROVIDED "AS IS" WITHOUT WARRANTY OF ANY KIND, EITHER EXPRESS OR IMPLIED, RELATING TO SALE AND/OR USE OF MACOM PRODUCTS INCLUDING LIABILITY OR WARRANTIES RELATING TO FITNESS FOR A PARTICULAR PURPOSE, CONSEQUENTIAL OR INCIDENTAL DAMAGES, MERCHANTABILITY, OR INFRINGEMENT OF ANY PATENT, COPYRIGHT OR OTHER INTELLECTUAL PROPERTY RIGHT. MACOM FURTHER DOES NOT WARRANT THE ACCURACY OR COMPLETENESS OF THE INFORMATION, TEXT, GRAPHICS OR OTHER ITEMS CONTAINED WITHIN THESE MATERIALS. MACOM SHALL NOT BE LIABLE FOR ANY SPECIAL, INDIRECT, INCIDENTAL, OR CONSEQUENTIAL DAMAGES, INCLUDING WITHOUT LIMITATION, LOST REVENUES OR LOST PROFITS, WHICH MAY RESULT FROM THE USE OF THESE MATERIALS.

MACOM products are not intended for use in medical, lifesaving or life sustaining applications. MACOM customers using or selling MACOM products for use in such applications do so at their own risk and agree to fully indemnify MACOM for any damages resulting from such improper use or sale.

X-ON Electronics

Largest Supplier of Electrical and Electronic Components

Click to view similar products for [Attenuators](#) category:

Click to view products by [MACOM](#) manufacturer:

Other Similar products are found below :

[HMC305SLP4ETR](#) [MAAD-009195-000100](#) [TGL4201-00](#) [TGL4201-02](#) [TGL4201-03](#) [TGL4201-06](#) [TGL4201-10](#) [ATN3590-15](#) [20-50TPC](#)
[D10AA5Z4](#) [18AH-01](#) [18AH-08](#) [ATN3590-09](#) [20-50RP](#) [PCAF-10](#) [EXB-24AT9AR5X](#) [ATN3580-06](#) [ATN3580-10](#) [HMC539ALP3ETR](#)
[ATN3580-02](#) [WA04P006XCTL](#) [SKY12408-321LF](#) [ATN3580-03](#) [WA04P005XBTL](#) [HMC-VVD104-SX](#) [WA04P007XCTL](#) [SKY12236-11](#)
[MAATSS0018TR-3000](#) [HMC656-SX](#) [WA04P001XBTL](#) [MAAV-007941-TR3000](#) [WA04P004XBTL](#) [WA04P002XBTL](#) [EXB-24N182JX](#)
[EXB-24N181JX](#) [EXB-24N183JX](#) [C3A50Z4](#) [HMC941A](#) [PAT0816-C-0DB-T5](#) [PAT0816-C-8DB-T5](#) [PAT1632-C-3DB-T1](#) [PAT1632-C-6DB-](#)
[T1](#) [PAT1632-C-10DB-T1](#) [PAT1632-C-1DB-T1](#) [PAT0816-C-2DB-T5](#) [PAT0816-C-4DB-T5](#) [DHM510-0100-006](#) [CMD172](#) [MAT10300](#)
[MAT10180](#)