

Features

- Low I_R (<100nA @ 1V, <500nA @ 3V)
- Designed for High Volume, Low Cost Detector and Mixer Applications
- High Detector Sensitivity: -55 dBm TSS
- Low Capacitance: 0.30 pF
- Low 1/F Noise
- Single, Series Pair, and Unconnected Pair Configurations
- Lead Free (RoHS Compliant) Equivalents Available With 260 Deg. C Reflow Capability
- Tape and Reel

Description and Applications

The MA4E2054 series are low barrier n-type silicon Schottky diodes assembled in low cost surface mount plastic packages. They are designed for use as high performance mixer and detector diodes.

These parts are offered with Sn/Pb plating, as well as with 100 % matte Sn plating on the RoHS compliant part numbers.

The MA4E2054 -1141T (SOD-323), MA4E20541 -1279 (SC-79) and the MA4E2054A and MA4E2054C (available in both the SOT-23 and SOT-323 packages) are single element Schottky diodes characterized for use as single ended mixers and detectors. The MA4E2054B and MA4E2054D (available in both the SOT-23 and SOT-323 packages) incorporate two Schottky chips in series pair configurations. The MA4E2054E-1068T consists of two Schottky chips in the SOT-143 package in an unconnected pair configuration. These diodes are useful for balanced mixer and detector voltage doubler circuits. Applications for the MA4E2054 series include VSAT and DBS mixers. The small diode package size and low cost make them attractive for use in RF tag applications for identification and toll collection.

The part number consists of the base chip (MA4E2054), followed by the wiring configuration (A, B, C, D, E, omit for SOD-323), the package style (287, 1068, 1141, 1146) and a "T" for tape and reel.

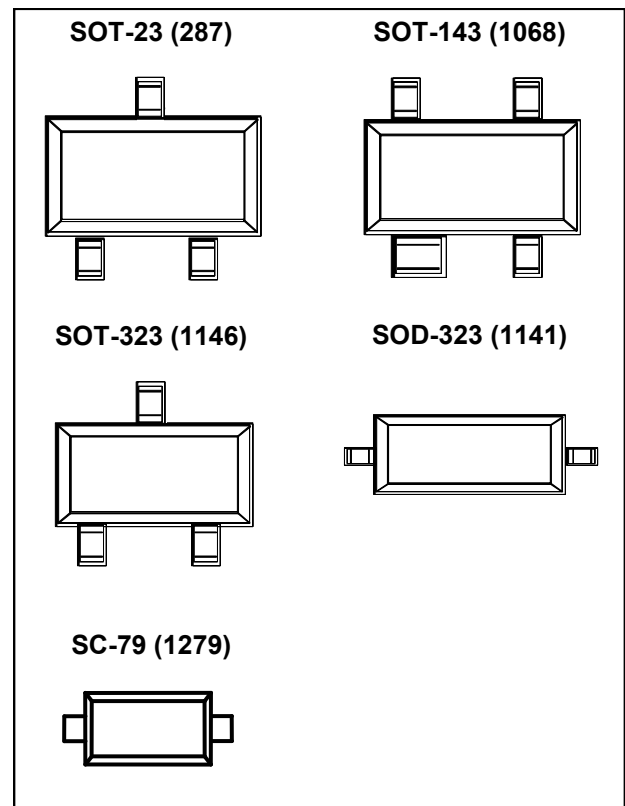

Configurations (Topviews)

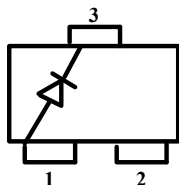

SINGLE
MA4E2054A-287T
MA4E2054A-1146T

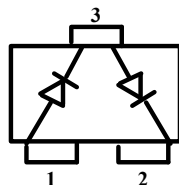

SERIES PAIR
MA4E2054B-287T
MA4E2054B-1146T

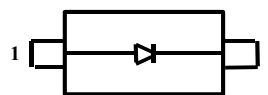

Single
MA4E2054-1141T
MA4E20541-1279T

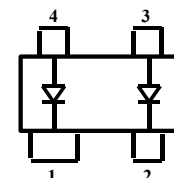

Unconnected Pair
MA4E2054E-1068T

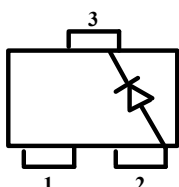

SINGLE
MA4E2054C-287T
MA4E2054C-1146T

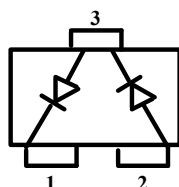

SERIES PAIR
MA4E2054D-287T
MA4E2054D-1146T

Spice Model Parameters

$IS = 3 \times 10^{-8} \text{ A}$	$M = 0.50$
$RS = 11\Omega$	$EG = 0.69 \text{ eV}$
$N = 1.05$	$BV = 5.0 \text{ V}$
$TT = 0 \text{ S}$	$IBV = 1 \times 10^{-5} \text{ A}$
$Cj(0) = 0.13 \times 10^{-12} \text{ pF}$	
$Cpar = 0.14 \times 10^{-12} \text{ pF}$	
$VJ = 0.40 \text{ V}$	

Standard Part Numbers and RoHS Equivalents

Standard Part Number	RoHS Compliant Part Number	Package Style
MA4E2054A-287T	MA4E2054A1-287T	SOT-23
MA4E2054A-1146T	MA4E2054A1-1146T	SOT-323
MA4E2054B-287T	MA4E2054B1-287T	SOT-23
MA4E2054B-1146T	MA4E2054B1-1146T	SOT-323
MA4E2054C-287T	MA4E2054C1-287T	SOT-23
MA4E2054C-1146T	MADS-002054-1146CT	SOT-323
MA4E2054D-287T	MA4E2054D1-287T	SOT-23
MA4E2054D-1146T	MADS-002054-1146DT	SOT-323
MA4E2054-1141T	MA4E20541-1141T	SOD-323
MA4E2054E-1068T	MA4E2054E1-1068T	SOT-143
N/A	MA4E20541-1279T	SC-79

Maximum Ratings

Parameter	Unit	Maximum Ratings
Operating Temperature	°C	-65 to +125
Storage Temperature	°C	-65 to +125
Incident RF Power (CW)	mW	75*
Reverse Voltage @ 25 °C	V	3
Forward Current	mA	20
Soldering Temperature (Standard Part #)	°C	+235 for 5 sec.
Soldering Temperature (Lead Free Part #)	°C	+260 for 5 sec.

* At 125 °C case temperature. Derate linearly to zero watts at 125 °C case temperature.

Electrical Specifications @ +25 °C

Parameter	Condition	Symbol	Specification
Breakdown Voltage	$I_R = 10 \mu\text{A}$	V_B	3.0 V min.
Reverse Leakage Current	$V_R = 1 \text{ V}$	I_R	100 nA max.
Reverse Leakage Current	$V_R = 3 \text{ V}$	I_R	500 nA max.
Total Capacitance	$V_R = 0 \text{ V}$ $f = 1 \text{ MHz}$	C_T	0.30 pF max.
Dynamic Resistance ²	$I_F = 10 \text{ mA}$	R_D	17 Ohms max.
Forward Voltage	$I_F = 1 \text{ mA}$	V_F	250 mV min. 350 mV min.
Forward Voltage Difference ¹	$I_F = 1 \text{ mA}$	V_F	20 mV max.

1. Applies to MA4E2054B, MA4E2054D and MA4E2054E configurations.

2. $R_D = R_S + R_J$ where $R_J = \frac{26}{I_F}$ (in mA)

Typical RF Performance @ +25 °C in Chip Form, Mounted on a Microstrip Fixture

Parameter	Conditions	Typical Value
Mixer Noise Figure ¹	$f = 9.375 \text{ GHz}$ $LO = 0 \text{ dBm}$	5.7 dB (SSB)
IF Impedance	$I_F = 30 \text{ MHz}$	200 ohms
Tangential Signal Sensitivity ²	$I_F = 20 \text{ mA}$ $BW = 2 \text{ MHz}$ Video NF = 1.5 dB	-55 dBm
Detector Output, Voltage at -30 dBm ²	$R_L = 100\text{K Ohms}$ $I_F = 20 \mu\text{A}$	20 mV
Detector Output, Voltage at -30 dBm ²	$R_L = 1\text{M Ohm}$	20 mV

1. Fixture tuned to 9.375 GHz.

2. Fixture tuned to 2.5 GHz. See figures on page 3 for untuned fixture performance.

3

Circuit Models

SOT-23

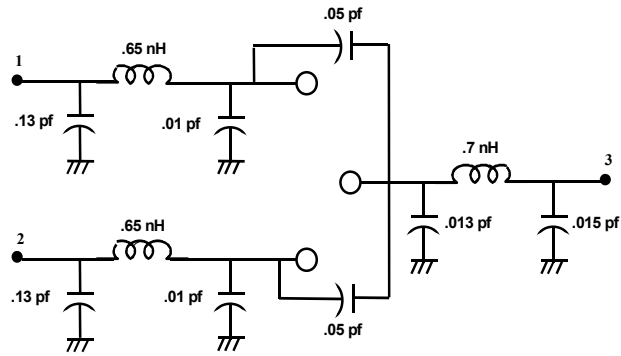

SOT-143

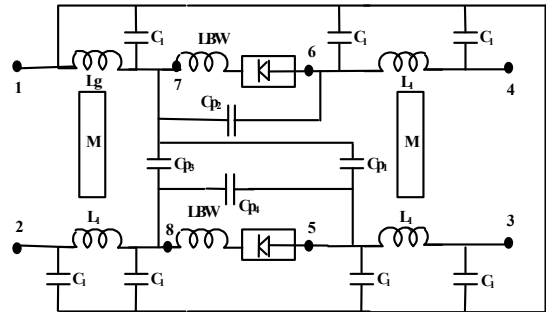

LBW = 0.08nH, Lg = 0.36nH, L1 = 0.31nH, M = 0.12nH, C1 = 0.01pF, Cp1 = 0.05pF, CP2 = 0.10pF, Cp3 = 0.05pF, Cp4 = 0.03pF

SOT-323

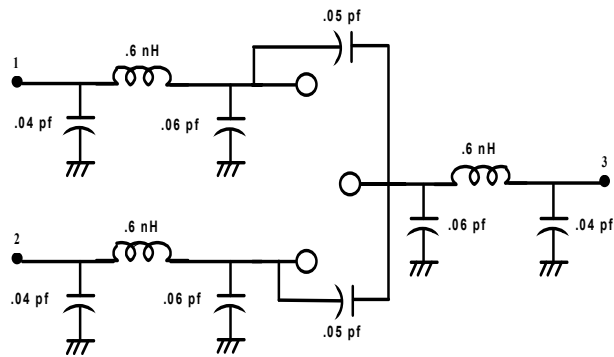

SOD-323

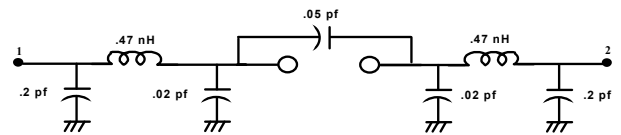

Typical Performance Curves @ 25°C in Chip Form, Mounted on a Microstrip Fixture

Detector Output Voltage vs Frequency and Load Resistance at -30 dBm. Diode Forward Biased at 20μA. Untuned Fixture (50Ω)

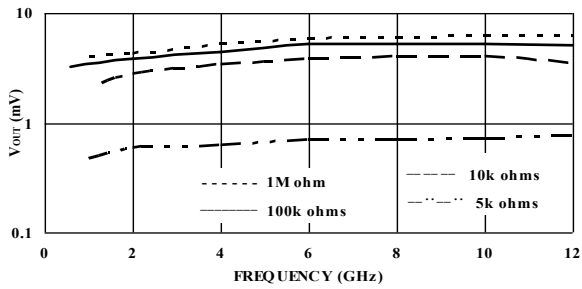

Forward Current vs Forward Voltage and Temperature

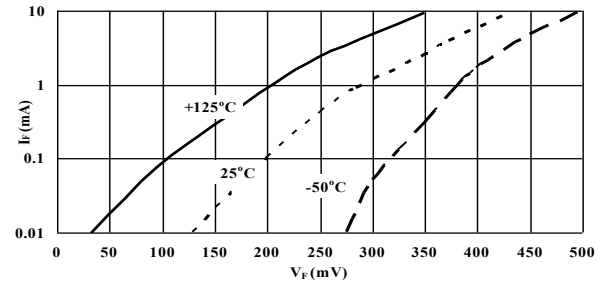

Detector Output Voltage vs Input Power and Load Resistance. Diode Forward Biased at 20μA. Untuned Fixture at 9.375 GHz.

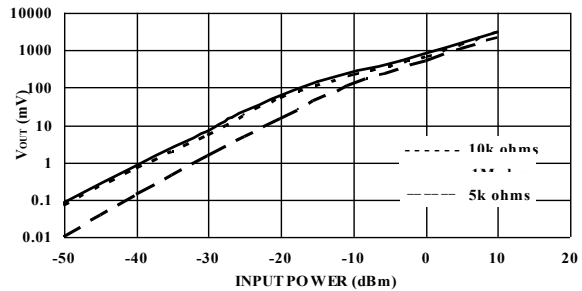

Detector Output Voltage vs Input Power and Load Resistance. Diode at Zero Bias. Untuned Fixture at 9.375 GHz (50Ω)

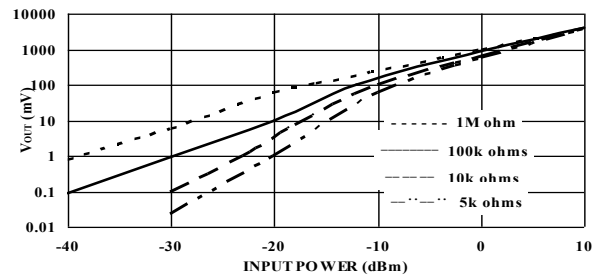

Detector Output Voltage vs Frequency and Load Resistance at -30 dBm. Diode at Zero Bias. Untuned Fixture.

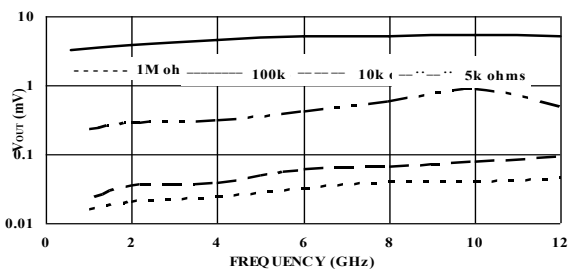

Tuned Fixture Noise Figure vs LO Power at 9.375 GHz

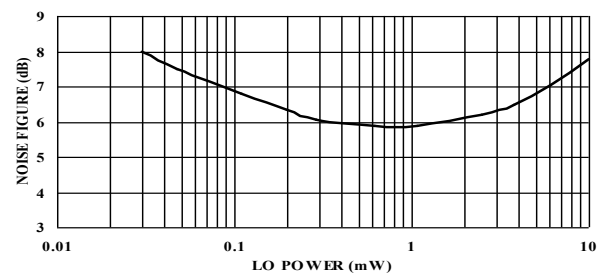

Typical Scattering Parameters (S11)

MA4E2054A Chip Form, Mounted on a Microstrip Fixture (no DC bias)

Freq. GHz	-30 dBm		-3 dBm		0 dBm		3 dBm	
	MAG	PHASE	MAG	PHASE	MAG	PHASE	MAG	PHASE
0.50	0.993	-7.6	0.812	-7.0	0.597	-4.6	0.387	-0.9
1.00	0.994	-15.1	0.843	-14.7	0.632	-13.9	0.411	-11.3
1.50	0.993	-21.4	0.807	-21.7	0.596	-22.3	0.386	-22.4
2.00	0.997	-27.1	0.791	-26.0	0.580	-23.1	0.383	-16.4
2.50	0.994	-33.2	0.795	-31.5	0.579	-27.6	0.378	-18.5
3.00	0.994	-41.3	0.755	-42.7	0.548	-45.2	0.342	-48.6
3.50	0.992	-48.6	0.727	-52.2	0.524	-55.8	0.318	-60.8
4.00	0.997	-56.5	0.713	-58.9	0.502	-59.5	0.296	-56.3
4.50	0.987	-66.4	0.696	-67.1	0.464	-67.7	0.235	-62.6
5.00	0.971	-74.7	0.634	-79.8	0.386	-86.2	0.167	-94.9
5.50	0.965	-83.1	0.614	-88.6	0.354	-91.4	0.131	-98.7
6.00	0.980	-96.0	0.547	-103.5	0.292	-107.0	0.072	-117.2
6.50	0.974	-110.3	0.514	-120.1	0.248	-129.5	0.041	163.9
7.00	0.941	-123.7	0.450	-137.4	0.235	-150.8	0.070	145.2
7.50	0.957	-138.9	0.430	-158.1	0.247	178.0	0.152	120.6
8.00	0.969	-155.6	0.404	-178.8	0.260	150.1	0.218	102.5
8.50	0.933	-171.5	0.405	162.2	0.294	129.9	0.278	92.0
9.00	0.932	170.9	0.391	143.1	0.310	110.8	0.344	84.4
9.50	0.943	152.8	0.410	128.2	0.318	97.9	0.343	68.7
10.00	0.931	132.2	0.504	108.9	0.394	83.3	0.399	56.9

Case Styles

SOT-23

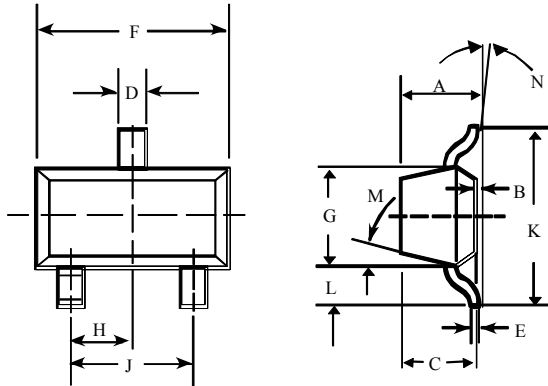

Package Parasitics

$L_s = 1.4 \text{ nH}$
 $C_p = .12 \text{ pF}$

SOT-23 (Case Style 287)

DIM.	INCHES		MILLIMETERS	
	MIN.	MAX.	MIN.	MAX.
A	-	0.048	-	1.22
B	-	0.008	-	0.20
C	-	0.040	-	1.00
D	0.013	0.020	0.35	0.50
E	0.003	0.006	0.08	0.15
F	0.110	0.119	2.80	3.00
G	0.047	0.056	1.20	1.40
H	0.037 typical		0.95 typical	
J	0.075 typical		1.90 typical	
K	-	0.103	-	2.60
L	-	0.024	-	0.60
DIM.	GRADIENT			
M	10° max. ¹			
N	2° ... 30°			

Note: 1. Applicable on all sides

SOT-143

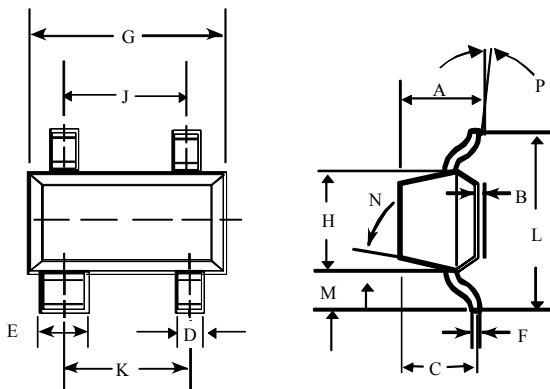

Package Parasitics

$L_s = 1.2 \text{ nH}$
 $C_p = .14 \text{ pF}$

SOT-143 (Case Style 1068)

DIM.	INCHES		MILLIMETERS	
	MIN.	MAX.	MIN.	MAX.
A	-	0.044	-	1.10
B	-	0.044	-	1.10
C	-	0.040	-	1.00
D	0.013	0.020	0.35	0.50
E	0.030	0.035	0.75	0.90
F	0.003	0.006	0.08	0.15
G	0.110	0.119	2.80	3.00
H	0.047	0.056	1.20	1.40
J	0.075 typical		1.90 typical	
K	0.075 typical		1.90 typical	
L	-	0.103	-	2.6
M	-	0.024	-	0.6
DIM.	GRADIENT			
N	10° max. ¹			
P	2° ... 30°			

Note: 1. Applicable on all sides

Case Styles (Cont'd)

SOT-323

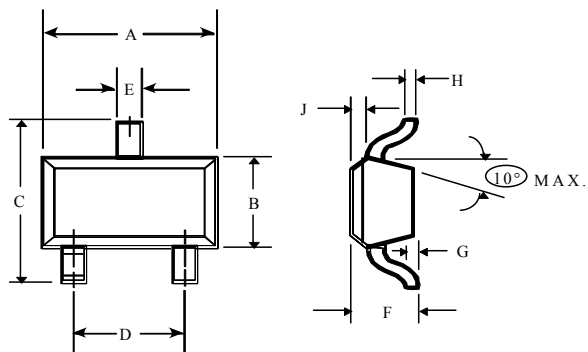

Package Parasitics

$L_s = 1.2 \text{ nH}$

$C_p = .11 \text{ pF}$

SOT-323 (Case Style 1146)

DIM.	INCHES		MILLIMETERS	
	MIN.	MAX.	MIN.	MAX.
A	0.063	0.087	1.6	2.2
B	0.045	0.053	1.15	1.35
C	0.079	0.087	2.0	2.2
D	0.047	0.055	1.2	1.4
E	0.008	0.016	0.2	0.4
F	0.031	0.039	0.8	1.0
G	-	0.004	-	0.1
H	0.003	0.006	0.08 typical	0.15
J	0.004	0.010	0.1	0.25

SOD-323

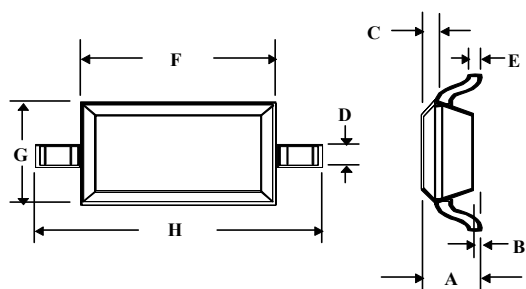

Package Parasitics

$L_s = 1.2 \text{ nH}$

$C_p = .11 \text{ pF}$

SOD-323 (Case Style 1141)

DIM.	INCHES		MILLIMETERS	
	MIN.	MAX.	MIN.	MAX.
A	-	0.043	-	1.1
B	-	0.004	-	0.1
C	-	0.008	-	0.2
D	0.010	0.016	0.25	0.4
E	0.003	0.006	0.08	0.15
F	0.063	0.075	1.6	1.9
G	0.045	0.057	1.15	1.45
H	0.091	0.106	2.3	2.7

Case Styles (Cont'd)

ODS-1279

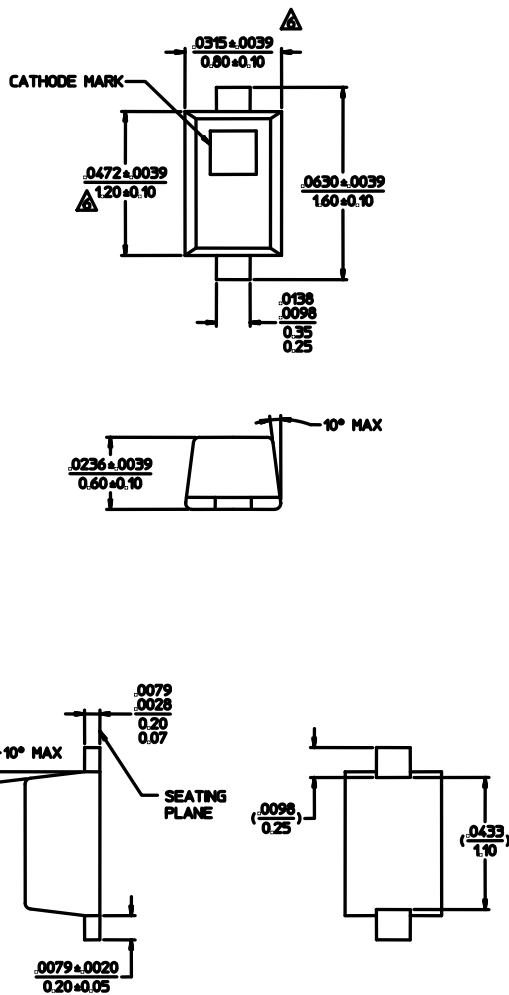

Package Parasitics

$L_s = .6 \text{ nH}$
 $C_p = .10 \text{ pF}$

M/A-COM Technology Solutions Inc. All rights reserved.

Information in this document is provided in connection with M/A-COM Technology Solutions Inc ("MACOM") products. These materials are provided by MACOM as a service to its customers and may be used for informational purposes only. Except as provided in MACOM's Terms and Conditions of Sale for such products or in any separate agreement related to this document, MACOM assumes no liability whatsoever. MACOM assumes no responsibility for errors or omissions in these materials. MACOM may make changes to specifications and product descriptions at any time, without notice. MACOM makes no commitment to update the information and shall have no responsibility whatsoever for conflicts or incompatibilities arising from future changes to its specifications and product descriptions. No license, express or implied, by estoppel or otherwise, to any intellectual property rights is granted by this document.

THESE MATERIALS ARE PROVIDED "AS IS" WITHOUT WARRANTY OF ANY KIND, EITHER EXPRESS OR IMPLIED, RELATING TO SALE AND/OR USE OF MACOM PRODUCTS INCLUDING LIABILITY OR WARRANTIES RELATING TO FITNESS FOR A PARTICULAR PURPOSE, CONSEQUENTIAL OR INCIDENTAL DAMAGES, MERCHANTABILITY, OR INFRINGEMENT OF ANY PATENT, COPYRIGHT OR OTHER INTELLECTUAL PROPERTY RIGHT. MACOM FURTHER DOES NOT WARRANT THE ACCURACY OR COMPLETENESS OF THE INFORMATION, TEXT, GRAPHICS OR OTHER ITEMS CONTAINED WITHIN THESE MATERIALS. MACOM SHALL NOT BE LIABLE FOR ANY SPECIAL, INDIRECT, INCIDENTAL, OR CONSEQUENTIAL DAMAGES, INCLUDING WITHOUT LIMITATION, LOST REVENUES OR LOST PROFITS, WHICH MAY RESULT FROM THE USE OF THESE MATERIALS.

MACOM products are not intended for use in medical, lifesaving or life sustaining applications. MACOM customers using or selling MACOM products for use in such applications do so at their own risk and agree to fully indemnify MACOM for any damages resulting from such improper use or sale.

10

M/A-COM Technology Solutions Inc. (MACOM) and its affiliates reserve the right to make changes to the product(s) or information contained herein without notice.
Visit www.macom.com for additional data sheets and product information.

X-ON Electronics

Largest Supplier of Electrical and Electronic Components

Click to view similar products for [Rectifiers](#) category:

Click to view products by [MACOM](#) manufacturer:

Other Similar products are found below :

[D91A](#) [DA24F4100L](#) [DD89N1600K-A](#) [DD89N16K-K](#) [RL252-TP](#) [DLA11C-TR-E](#) [DSA17G](#) [DSEI2X30-06C](#) [1N4005-TR](#) [BAV199-TP](#)
[UFS120Je3/TR13](#) [JANS1N6640US](#) [VS-80-1293](#) [DD89N16K](#) [DD89N16K-A](#) [481235F](#) [DSP10G-TR-E](#) [067907F](#) [MS306](#) [ND104N08K](#)
[SPA2003-B-D-A01](#) [VS-80-6193](#) [VS-66-9903](#) [VGF0136AB](#) [US2JFL-TP](#) [UFS105Je3/TR13](#) [A1N5404G-G](#) [ACGRA4007-HF](#) [ACGRB207-HF](#)
[RF301B2STL](#) [RF501B2STL](#) [UES1306](#) [UES1302](#) [BAV199E6433HTMA1](#) [ACGRC307-HF](#) [ACEFC304-HF](#) [JANTXV1N5660A](#) [UES1106](#)
[GS2K-LTP](#) [D126A45C](#) [D251N08B](#) [SCHJ22.5K](#) [SM100](#) [SCPA2](#) [SCH10000](#) [SDHD5K](#) [STTH20P035FP](#) [VS-8EWS12S-M3](#) [VS-](#)
[12FL100S10](#) [ACGRA4001-HF](#)