

## High Dynamic Range IF Amplifier 50 - 1000 MHz

Rev. V2

### Features

- Single +5 V Supply Voltage
- 18 dB Gain
- +22 dBm P1dB
- +40 dBm OIP3
- 2.4 dB Noise Figure
- Lead-Free SOT-89 Package
- Halogen-Free “Green” Mold Compound
- RoHS\* Compliant and 260°C Re-flow Compatible

### Description

The MAAM-009116 is a high dynamic range amplifier in a lead-free SOT-89 surface mount plastic package. It can be operated from a single 5 volt supply.

The MAAM-009116 offers a combination of low noise figure, high gain, and high output IP3 making this an ideal IF amplifier for receiver and transmitter applications.

The MAAM-009116 is fabricated using M/A-COM Technology Solutions MESFET process to realize low noise and high dynamic range. The process features full passivation for performance and reliability.

### Ordering Information <sup>1,2</sup>

Part Number	Package
MAAM-009116-000000	Bulk Packaging
MAAM-009116-TR3000	3000 piece reel
MAAM-009116-001SMB	500 MHz Configuration

1. Reference Application Note M513 for reel size information.
2. All sample boards include 5 loose parts.

### Functional Block Diagram

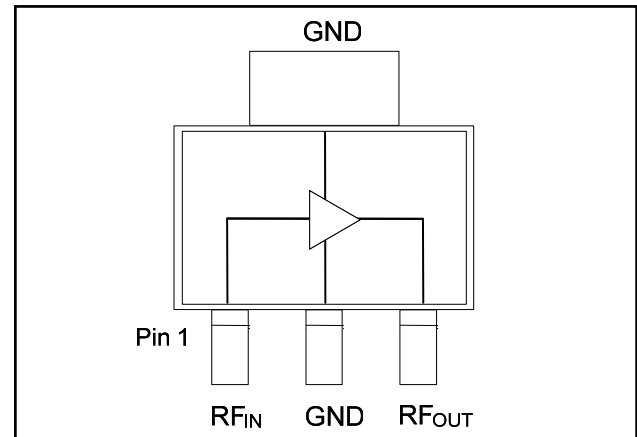

### Pin Configuration

Pin No.	Function	Pin No.	Function
1	RF Input	3	RF Output/Bias
2	Ground	4	Ground

### Maximum Operating Conditions<sup>3</sup>

Parameter	Maximum Operating Conditions
Junction Temperature <sup>4</sup>	150°C
RF Output Power	22 dBm
Operating Temperature	-40°C to +85°C

3. These operating conditions will ensure MTTF > 1 x 10<sup>6</sup> hours.

4. Junction Temperature ( $T_J$ ) =  $T_C + \Theta_{jc} * ((V * I) - (P_{OUT} - P_{IN}))$   
Typical thermal resistance ( $\Theta_{jc}$ ) = 70° C/W.

a) For  $T_C = 25^\circ\text{C}$ ,

$T_J = 88^\circ\text{C}$  @ 5 V, 180 mA,  $P_{OUT} = 5$  dBm,  $P_{IN} = -13$  dBm

b) For  $T_C = 85^\circ\text{C}$ ,

$T_J = 143^\circ\text{C}$  @ 5 V, 165 mA,  $P_{OUT} = 4.7$  dBm,  $P_{IN} = -13$  dBm

### Absolute Maximum Ratings<sup>5,6</sup>

Parameter	Absolute Maximum
RF Input Power	20 dBm
Voltage	6 volts
Storage Temperature	-55°C to +150°C
Junction Temperature	175°C

5. Exceeding any one or combination of these limits may cause permanent damage to this device.
6. M/A-COM Tech does not recommend sustained operation near these survivability limits.

\* Restrictions on Hazardous Substances, European Union Directive 2002/95/EC.

**ADVANCED:** Data Sheets contain information regarding a product M/A-COM Technology Solutions is considering for development. Performance is based on target specifications, simulated results, and/or prototype measurements. Commitment to develop is not guaranteed.

**PRELIMINARY:** Data Sheets contain information regarding a product M/A-COM Technology Solutions has under development. Performance is based on engineering tests. Specifications are typical. Mechanical outline has been fixed. Engineering samples and/or test data may be available. Commitment to produce in volume is not guaranteed.

• **North America** Tel: 800.366.2266 • **Europe** Tel: +353.21.244.6400  
• **India** Tel: +91.80.43537383 • **China** Tel: +86.21.2407.1588

Visit [www.macomtech.com](http://www.macomtech.com) for additional data sheets and product information.

M/A-COM Technology Solutions Inc. and its affiliates reserve the right to make changes to the product(s) or information contained herein without notice.

## High Dynamic Range IF Amplifier 50 - 1000 MHz

Rev. V2

### Electrical Specifications for Single Ended Performance: $Z_0 = 50 \Omega$ , $T_A = 25^\circ\text{C}$ , $V_{DD} = +5\text{V}$

Parameter	Test Conditions	Units	Min.	Typ.	Max.
Gain	500 MHz	dB	15	18	—
Noise Figure	500 MHz	dB	—	2.4	—
Input Return Loss	500 MHz	dB	—	13	—
Output Return Loss	500 MHz	dB	—	12	—
Output P1dB	500 MHz	dBm	—	22	—
Output IP <sub>3</sub>	500 MHz	dBm	37	40	—
Current	$V_{DD} = +5\text{V}$	mA	—	180	200

### PCB Layout

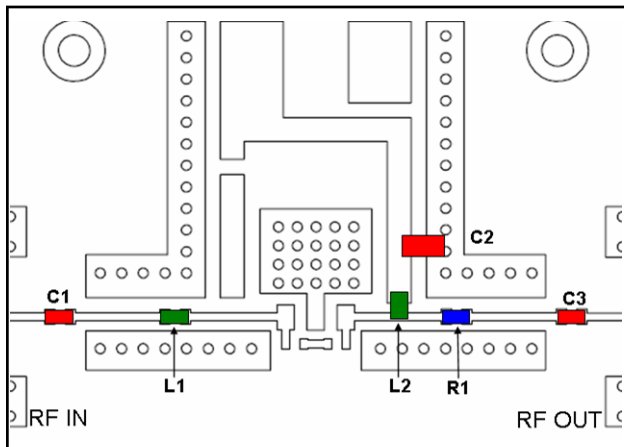

### Parts List

Part	Value	Case Style	Manufacturer
C1,C3	1000 pF	0402	Murata
C2	0.018 $\mu\text{F}$	0805	Murata
L1	22 nH	0402	Coilcraft
L2	150 nH	0603	Coilcraft
R1	8.2 $\Omega$	0402	Panasonic

### Application Schematic

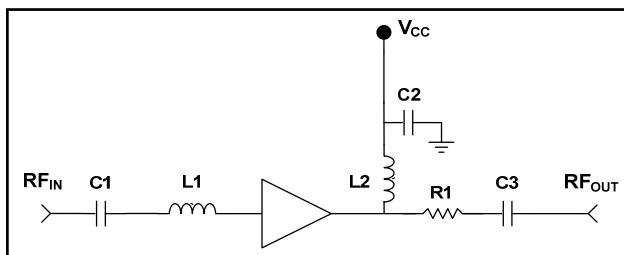

### Typical Performance Curves

**Gain**

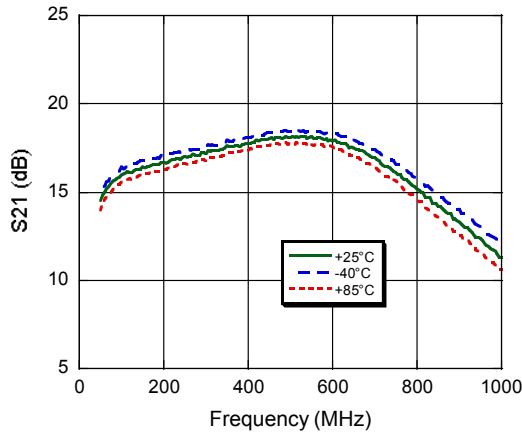

**Input Return Loss**

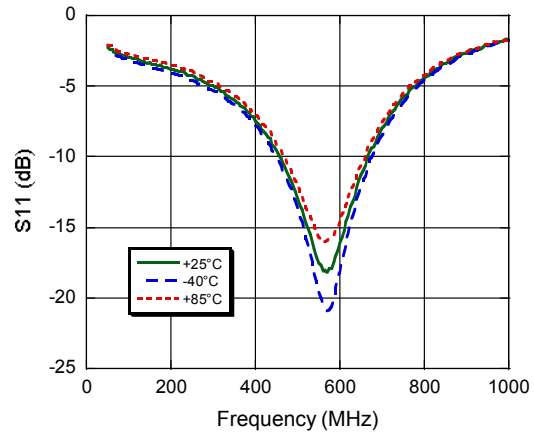

**Output Return Loss**

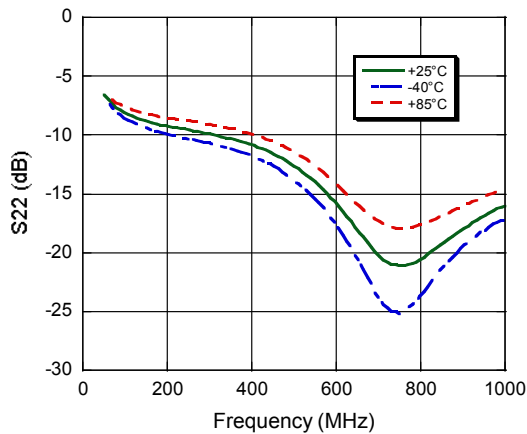

**Noise Figure**

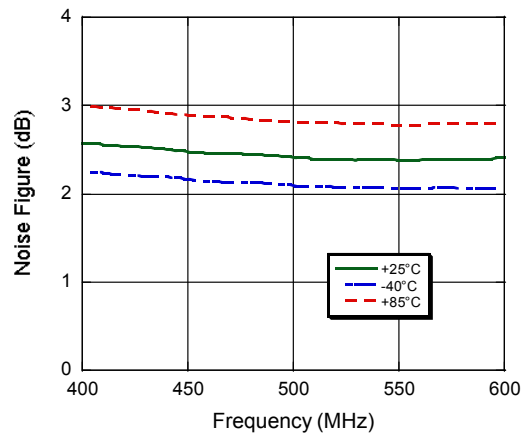

**IP3**

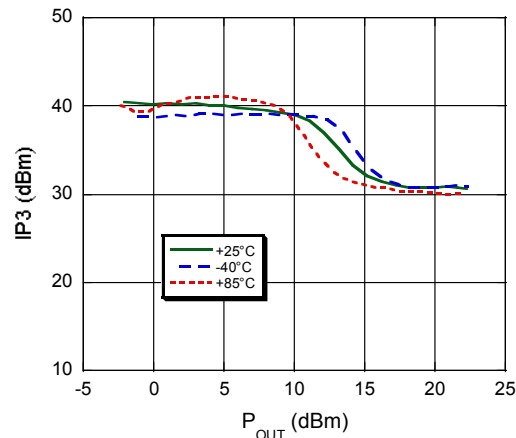

**Gain**

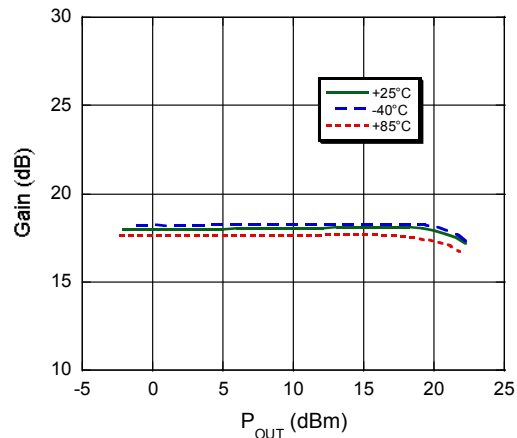

### Typical Performance Curves

#### Current

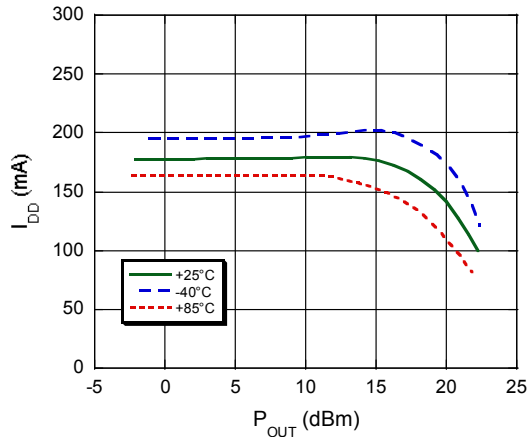

### Handling Procedures

Please observe the following precautions to avoid damage:

### Static Sensitivity

Gallium Arsenide Integrated Circuits are sensitive to electrostatic discharge (ESD) and can be damaged by static electricity. Proper ESD control techniques should be used when handling these devices.

### Lead Free SOT-89 Plastic Package<sup>†</sup>

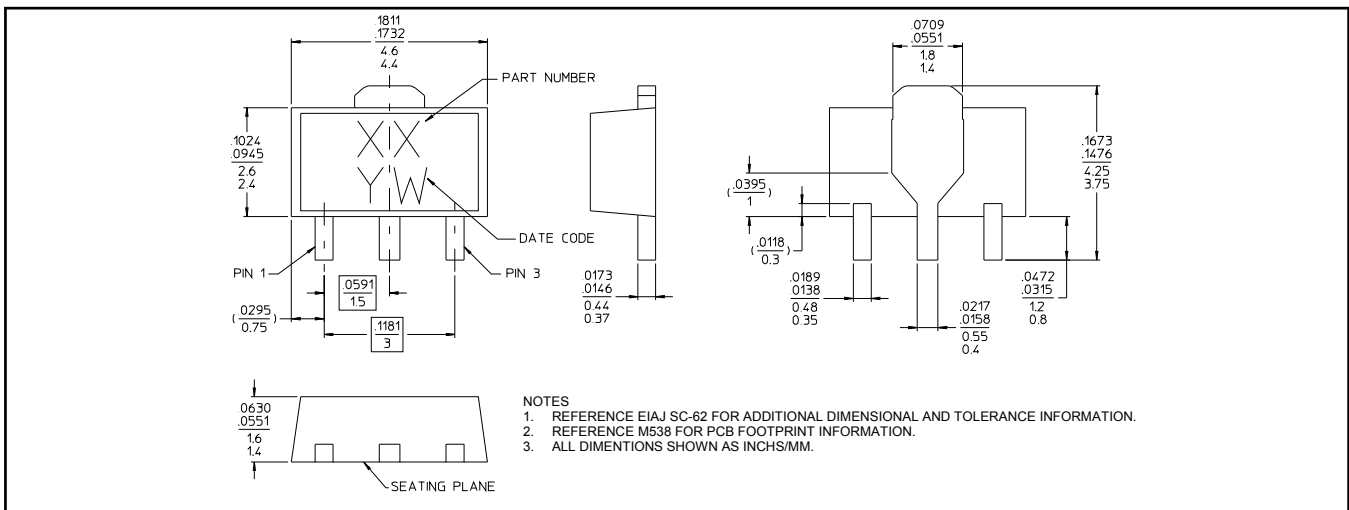

<sup>†</sup> Reference Application Note M538 for lead-free solder reflow recommendations.  
Meets JEDEC moisture sensitivity level 1 requirements.  
Plating is 100% matte tin over copper.

## X-ON Electronics

Largest Supplier of Electrical and Electronic Components

*Click to view similar products for [RF Amplifier](#) category:*

*Click to view products by [MACOM](#) manufacturer:*

Other Similar products are found below :

[ADPA7006AEHZ](#) [CXE2089ZSR](#) [MGA-43828-BLKG](#) [A82-1](#) [RF2878TR7](#) [BGA 728L7 E6327](#) [BGB719N7ESDE6327XTMA1](#) [HMC1126-SX](#) [HMC342](#) [HMC561-SX](#) [HMC598-SX](#) [HMC-ALH382-SX](#) [HMC-ALH476-SX](#) [SE2433T-R](#) [SE2622L-R](#) [SMA3101-TL-E](#) [SMA39](#) [SMA70-1](#) [A66-1](#) [A66-3](#) [A67-1](#) [LX5535LQ](#) [LX5540LL](#) [RF2373TR7](#) [HMC3653LP3BETR](#) [HMC395](#) [HMC549MS8GETR](#) [HMC576-SX](#) [HMC754S8GETR](#) [HMC-ALH435-SX](#) [SMA101](#) [SMA1031](#) [SMA181](#) [SMA32](#) [SMA411](#) [SMA531](#) [SST12LP17E-XX8E](#) [SST12LP19E-QX6E](#) [TGA2598](#) [WPM0510A](#) [HMC5929LS6TR](#) [HMC5879LS7TR](#) [HMC906A-SX](#) [HMC1127](#) [HMC544A](#) [HMC1126](#) [HMC1110-SX](#) [HMC1087F10](#) [HMC1086](#) [HMC1016](#)