

Push Pull CATV Amplifier 50 - 1000 MHz

Rev. V1

Features

- Low Distortion
- Low Noise Figure
- Push Pull Design
- Single Positive Supply
- Lead-Free 4 mm 20-Lead PQFN package
- Halogen-Free “Green” Mold Compound
- RoHS* Compliant and 260°C Reflow Compatible

Description

M/A-COM's MAAMSS0044 is a GaAs PHEMT MMIC amplifier in a lead-free 4 mm 20-lead PQFN package. The MMIC design is configured as a pair of cascode PHEMT amplifiers for broadband performance. It is designed for integration in a 75 Ω push-pull, low distortion, amplifier circuit. The device is ideally suited for use in CATV, FTTX, DBS, and HDTV applications where low noise figure and low distortion are required.

Ordering Information ^{1,2}

Part Number	Package
MAAMSS0044	Bulk Packaging
MAAMSS0044TR	1000 Piece Reel
MAAMSS0044TR-3000	3000 Piece Reel
MAAMSS0044SMB	Sample Board 50 - 1000 MHz Tuning

1. Reference Application Note M513 for reel size information.
2. All sample boards include 5 loose parts.

Functional Schematic

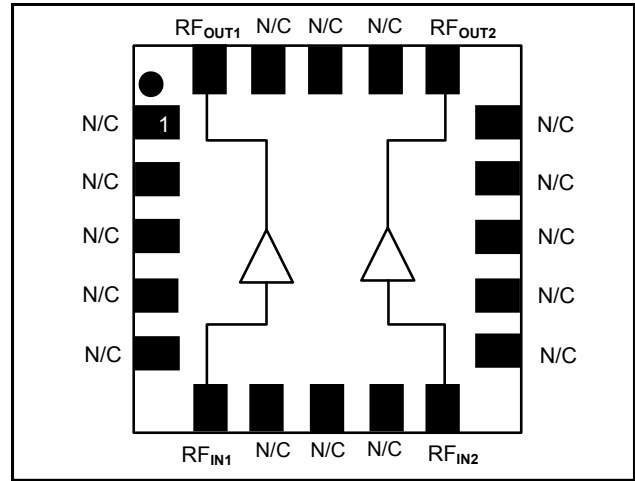

Pin Configuration ³

Pin No.	Pin Name	Description
1	N/C ⁴	No Connection
2	N/C	No Connection
3	N/C	No Connection
4	N/C	No Connection
5	N/C	No Connection
6	RF _{IN1}	RF Input 1
7	N/C	No Connection
8	N/C	No Connection
9	N/C	No Connection
10	RF _{IN2}	RF Input 2
11	N/C	No Connection
12	N/C	No Connection
13	N/C	No Connection
14	N/C	No Connection
15	N/C	No Connection
16	RF _{OUT2}	RF Output 2
17	N/C	No Connection
18	N/C	No Connection
19	N/C	No Connection
20	RF _{OUT1}	RF Output 1

3. The exposed pad centered on the package bottom must be connected to RF and DC ground.
4. It is recommended, but not absolutely compulsory, that all No Connections (N/C) within the IC are connected to the ground on the printed circuit board.

* Restrictions on Hazardous Substances, European Union Directive 2002/95/EC.

Push Pull CATV Amplifier 50 - 1000 MHz

Rev. V1

Electrical Specifications: $T_A = 25^\circ\text{C}$, Freq: 50 - 1000 MHz, $V_{DD} = +5$ Volts, $Z_0 = 75 \Omega$, Test Circuit with M/A-COM Balun MABACT0069

Parameter	Test Conditions	Units	Min.	Typ.	Max.
Gain	—	dB	11	12.5	13.5
Gain Flatness	—	dB	—	0.8	1.3
Noise Figure	—	dB	—	3.7	5
Input Return Loss	—	dB	—	15	—
Output Return Loss	—	dB	—	15	—
Output IP2	400 MHz, +4 dBm output	dBm	—	75	—
Output IP3	Two tones at 397 & 403 MHz, +8 dBm output/tone	dBm	—	42	—
Composite Triple Beat, CTB	79 Channels, +34 dBmV / Channel at the output	dBc	—	-75	-70
	77 Channels, +39 dBmV / Channel at the output	dBc	—	-65	—
Composite Second Order, CSO	79 Channels, +34 dBmV / Channel at the output	dBc	—	-85	-80
	77 Channels, +39 dBmV / Channel at the output	dBc	—	-75	—
Cross modulation	79 Channels, +34 dBmV / Channel at the output	dBc	—	-75	—
	77 Channels, +39 dBmV / Channel at the output	dBc	—	-65	—
P1dB	400 MHz	dBm	—	24	—
I_{DD}	+5 Volts	mA	—	225	280

Absolute Maximum Ratings^{5,6,7}

Parameter	Absolute Maximum
Input Power	+20 dBm
Operating Voltage	+10 volts
Operating Temperature	-40°C to +85°C
Junction Temperature ⁸	150°C
Storage Temperature	-65°C to +150°C

5. Exceeding any one or combination of these limits may cause permanent damage to this device.
6. M/A-COM does not recommend sustained operation near these survivability limits.
7. These operating conditions will ensure MTTF > 1 x 10⁶ hours.
8. Junction Temperature (T_J) = $T_C + \theta_{jc} * ((V * I) - (P_{OUT} - P_{IN}))$
Typical thermal resistance (θ_{jc}) = 39° C/W.
 - a) For $T_C = 25^\circ\text{C}$,
 $T_J = 69^\circ\text{C} @ 5 \text{ V}, 225 \text{ mA}$
 - b) For $T_C = 85^\circ\text{C}$,
 $T_J = 129^\circ\text{C} @ 5 \text{ V}, 225 \text{ mA}$

Handling Procedures

Please observe the following precautions to avoid damage:

Static Sensitivity

Gallium Arsenide Integrated Circuits are sensitive to electrostatic discharge (ESD) and can be damaged by static electricity. Proper ESD control techniques should be used when handling these devices.

Push Pull CATV Amplifier 50 - 1000 MHz

Rev. V1

PCB Land Pattern

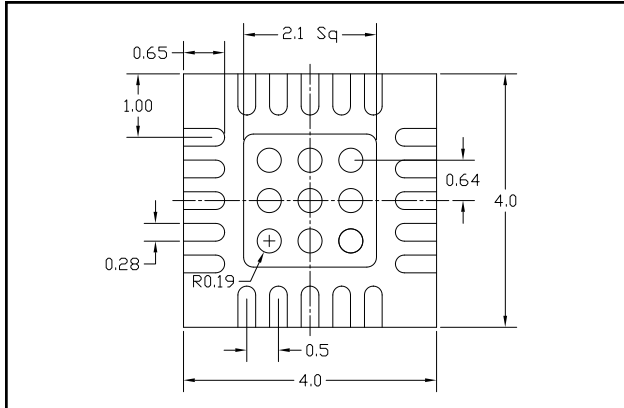

Parts List⁹

Component	Value	Package
C1 - C4	0.01 μ F	0402
C5	0.8 pF	0402
C6	1 pF	0402
C7 - C10	0.01 μ F	0402
L1	5.6 nH	0402
L2	6.8 nH	0402
L3, L4	470 nH	1008
R1, R2	300 Ω	0402

9. The 1:1 Baluns, T1 & T2 are M/A-COM part number MABACT0069

Application Schematic

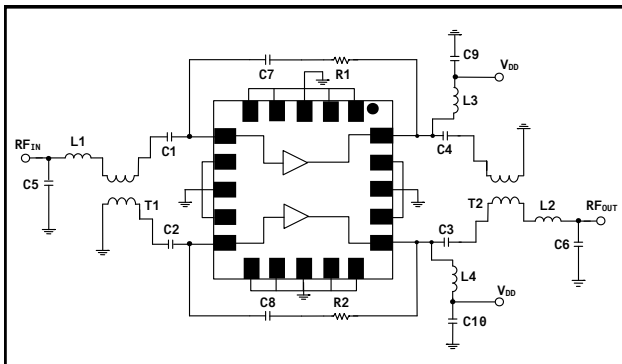

Sample Board

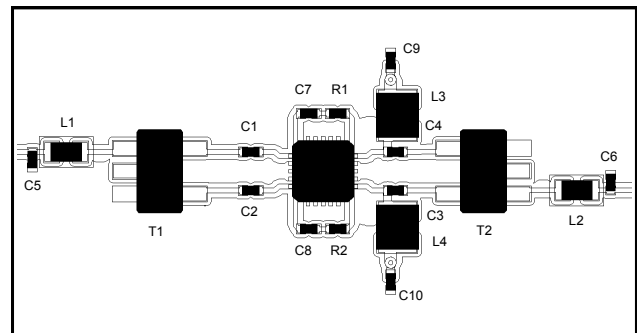

Lead Free 4 mm 20-lead PQFN[†]

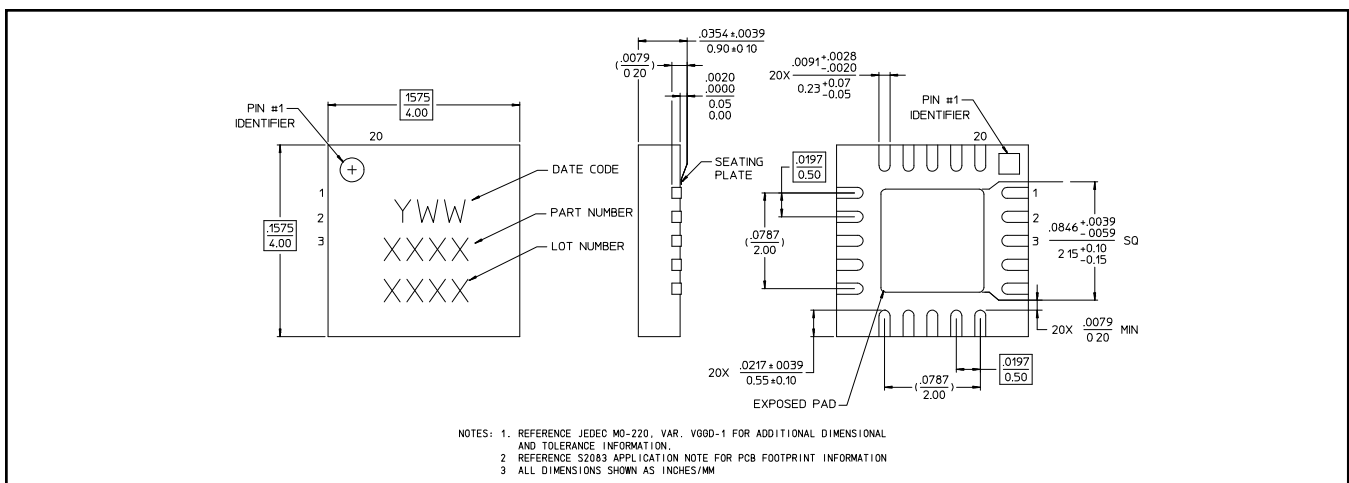

[†] Reference Application Note M538 for lead-free solder reflow recommendations.
Meets JEDEC moisture sensitivity level 1 requirements.
Plating is 100% matte tin over copper.

Push Pull CATV Amplifier 50 - 1000 MHz

Rev. V1

Typical Performance Curves

Gain vs. Frequency

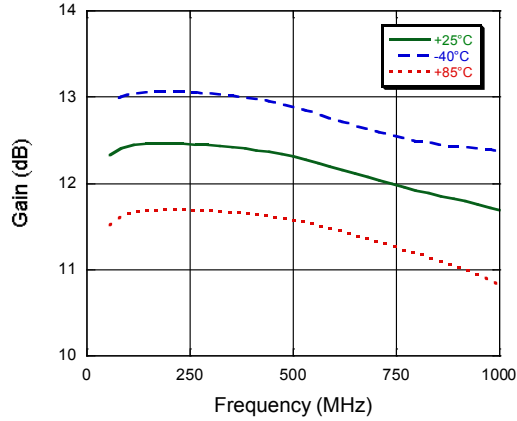

Gain vs. Frequency to 3 GHz

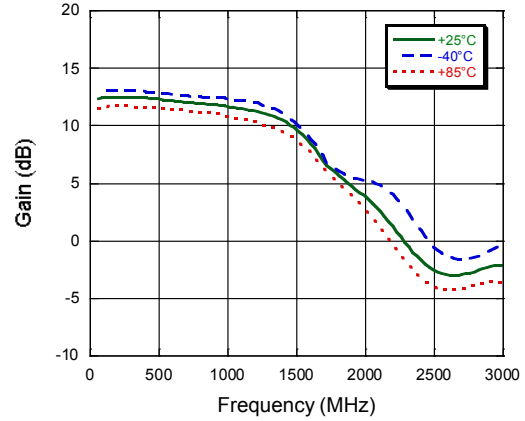

Input Return Loss vs. Frequency

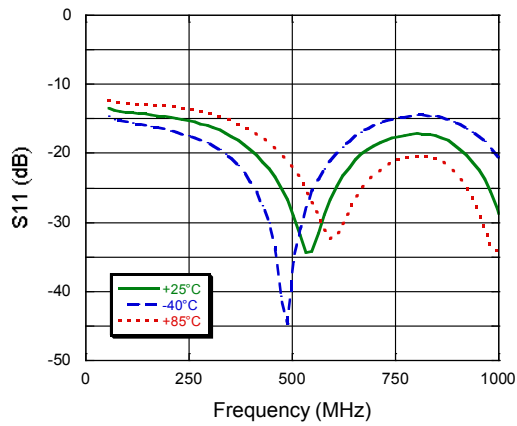

Output Return Loss vs. Frequency

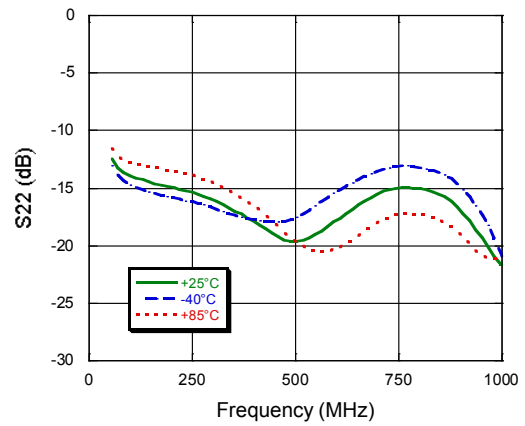

Noise Figure vs. Frequency

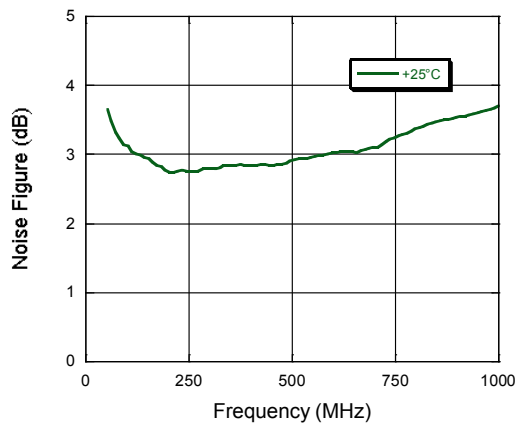

Typical Performance Curves

**Composite Triple Beat,
 79 Channels +34 dBm/channel Output**

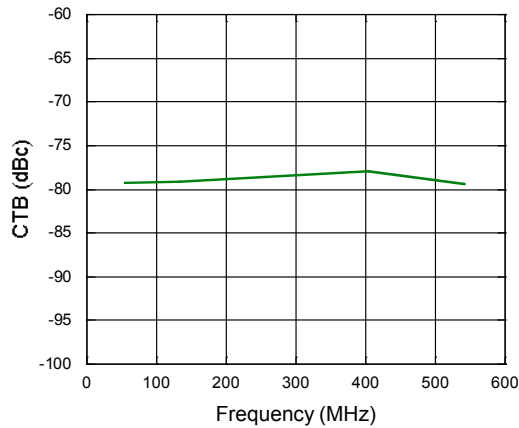

**Composite Triple Beat,
 77 Channels +39 dBm/channel Output**

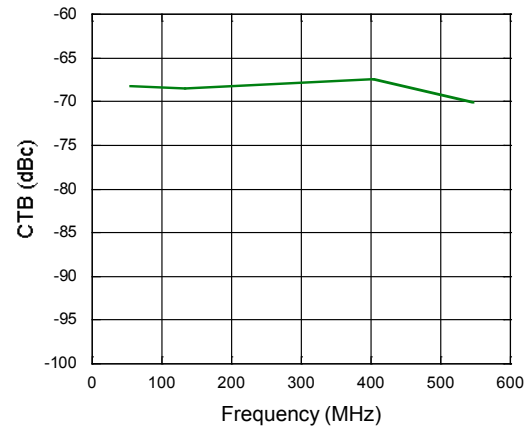

**Composite Second Order Low and High,
 79 Channels +34 dBm/channel Output**

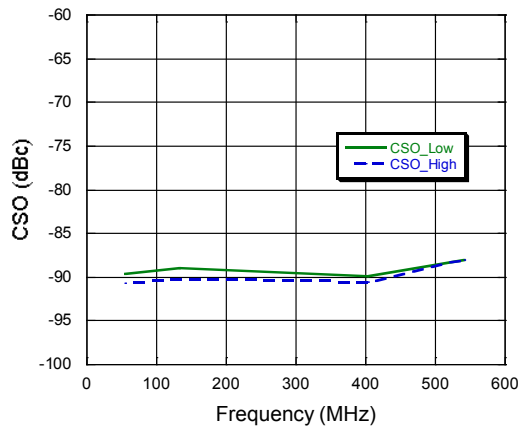

**Composite Second Order Low and High,
 77 Channels +39 dBm/channel Output**

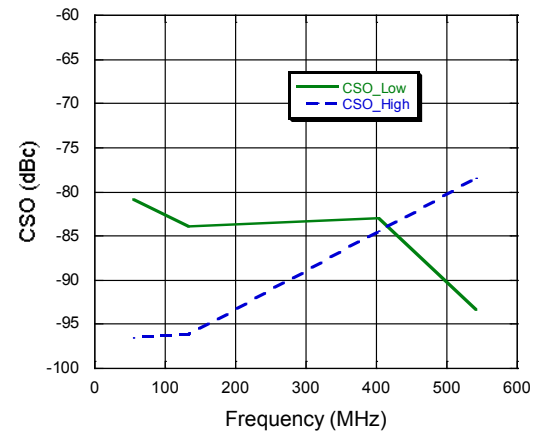

M/A-COM Technology Solutions Inc. All rights reserved.

Information in this document is provided in connection with M/A-COM Technology Solutions Inc ("MACOM") products. These materials are provided by MACOM as a service to its customers and may be used for informational purposes only. Except as provided in MACOM's Terms and Conditions of Sale for such products or in any separate agreement related to this document, MACOM assumes no liability whatsoever. MACOM assumes no responsibility for errors or omissions in these materials. MACOM may make changes to specifications and product descriptions at any time, without notice. MACOM makes no commitment to update the information and shall have no responsibility whatsoever for conflicts or incompatibilities arising from future changes to its specifications and product descriptions. No license, express or implied, by estoppel or otherwise, to any intellectual property rights is granted by this document.

THESE MATERIALS ARE PROVIDED "AS IS" WITHOUT WARRANTY OF ANY KIND, EITHER EXPRESS OR IMPLIED, RELATING TO SALE AND/OR USE OF MACOM PRODUCTS INCLUDING LIABILITY OR WARRANTIES RELATING TO FITNESS FOR A PARTICULAR PURPOSE, CONSEQUENTIAL OR INCIDENTAL DAMAGES, MERCHANTABILITY, OR INFRINGEMENT OF ANY PATENT, COPYRIGHT OR OTHER INTELLECTUAL PROPERTY RIGHT. MACOM FURTHER DOES NOT WARRANT THE ACCURACY OR COMPLETENESS OF THE INFORMATION, TEXT, GRAPHICS OR OTHER ITEMS CONTAINED WITHIN THESE MATERIALS. MACOM SHALL NOT BE LIABLE FOR ANY SPECIAL, INDIRECT, INCIDENTAL, OR CONSEQUENTIAL DAMAGES, INCLUDING WITHOUT LIMITATION, LOST REVENUES OR LOST PROFITS, WHICH MAY RESULT FROM THE USE OF THESE MATERIALS.

MACOM products are not intended for use in medical, lifesaving or life sustaining applications. MACOM customers using or selling MACOM products for use in such applications do so at their own risk and agree to fully indemnify MACOM for any damages resulting from such improper use or sale.

6

M/A-COM Technology Solutions Inc. (MACOM) and its affiliates reserve the right to make changes to the product(s) or information contained herein without notice.
Visit www.macom.com for additional data sheets and product information.

X-ON Electronics

Largest Supplier of Electrical and Electronic Components

Click to view similar products for [RF Amplifier](#) category:

Click to view products by [MACOM](#) manufacturer:

Other Similar products are found below :

[A82-1](#) [BGA622H6820XTSA1](#) [BGA 728L7 E6327](#) [BGB719N7ESDE6327XTMA1](#) [HMC397-SX](#) [HMC405](#) [HMC561-SX](#) [HMC8120-SX](#)
[HMC8121-SX](#) [HMC-ALH382-SX](#) [HMC-ALH476-SX](#) [SE2433T-R](#) [SMA3101-TL-E](#) [SMA39](#) [A66-1](#) [A66-3](#) [A67-1](#) [LX5535LQ](#) [LX5540LL](#)
[MAAM02350](#) [HMC3653LP3BETR](#) [HMC549MS8GETR](#) [HMC-ALH435-SX](#) [SMA101](#) [SMA32](#) [SMA411](#) [SMA531](#) [SST12LP17E-XX8E](#)
[SST12LP19E-QX6E](#) [WPM0510A](#) [HMC5929LS6TR](#) [HMC5879LS7TR](#) [HMC1126](#) [HMC1087F10](#) [HMC1086](#) [HMC1016](#) [SMA1212](#)
[MAX2689EWS+T](#) [MAAMSS0041TR](#) [MAAM37000-A1G](#) [LTC6430AIUF-15#PBF](#) [CHA5115-QDG](#) [SMA70-2](#) [SMA4011](#) [A231](#) [HMC-](#)
[AUH232](#) [LX5511LQ](#) [LX5511LQ-TR](#) [HMC7441-SX](#) [HMC-ALH310](#)