

Features

- Specified over Broad Bandwidth: 2 - 18 GHz
- Surface Mount
- Extremely Low Insertion Loss: < 0.3 dB
- High RF-DC Isolation: > 34 dB
- Rugged, Fully Monolithic Glass Encapsulation
- RoHS* Compliant and 260°C Reflow Compatible

Description

The MABT-011000 is a fully monolithic broadband surface mount bias network utilizing MACOM's patented HMIC process. This process allows the formation of silicon vias by imbedding them in low loss, low dispersion glass along with high Q spiral inductors and MIM capacitors. The close proximity of elements and the combination of silicon and glass give this HMIC device low loss and high performance with exceptional repeatability through millimeter frequencies.

Large vias reduce inductance and allow part to be more easily soldered, while the gold backside metallization provides the RF and DC ground. This allows for manual or automatic die attach via electrically conductive silver epoxy or RoHS compliant solders.

The MABT-011000 bias network is suitable for the DC biasing of PIN diode control circuits. It functions as an RF-DC de-coupling network as well as the DC return and contains a series DC blocking capacitor. DC currents up to 60 mA and DC voltages up to 50 V may be used.

Functional Schematic

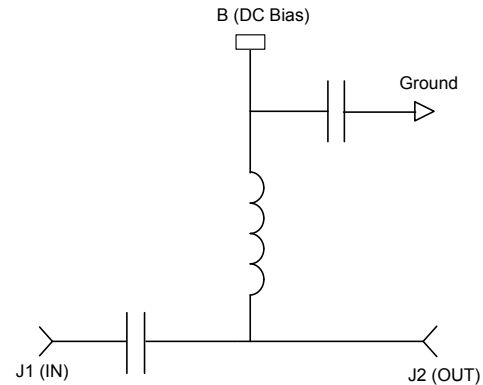

Pin Configuration

Pin	Function
J1	RF Input
J2	RF Output
B	DC Bias

Ordering Information¹

Part Number	Package
MABT-011000-14230G	Gel pack
MABT-011000-14230W	Wafer Frame
MABT-011000-14230P	3000 piece reel
MABT-011000-14235P	500 piece reel

1. Die quantity varies.

* Restrictions on Hazardous Substances, European Union Directive 2011/65/EU.

Electrical Specifications: T_A = 25°C

Parameter	Test Conditions	Units	Min.	Typ.	Max.
Insertion Loss (J1-J2)	2 GHz	dB	—	0.25	0.50
	6 GHz			0.10	0.30
	12 GHz			0.15	0.40
	18 GHz			0.25	0.50
RF - DC Isolation (J1-B, J2-B)	2 GHz	dB	30	34	—
	6 GHz		50	60	
	12 GHz		50	60	
	18 GHz		40	47	
Input Return Loss (J1)	2 GHz	dB	17	23	—
	6 GHz		17	35	
	12 GHz		17	34	
	18 GHz		17	26	
Output Return Loss (J2)	2 GHz	dB	17	22	—
	6 GHz		17	44	
	12 GHz		17	37	
	18 GHz		17	26	

Absolute Maximum Ratings^{2,3}

Parameter	Absolute Maximum
DC Bias Voltage	±50 V
DC Bias Current	±60 mA
Operating Temperature	-65°C to +125°C
Storage Temperature	-65°C to +150°C

- Exceeding any one or combination of these limits may cause permanent damage to this device.
- MACOM does not recommend sustained operation near these survivability limits.

Maximum RF Input De-Rating Curve⁴

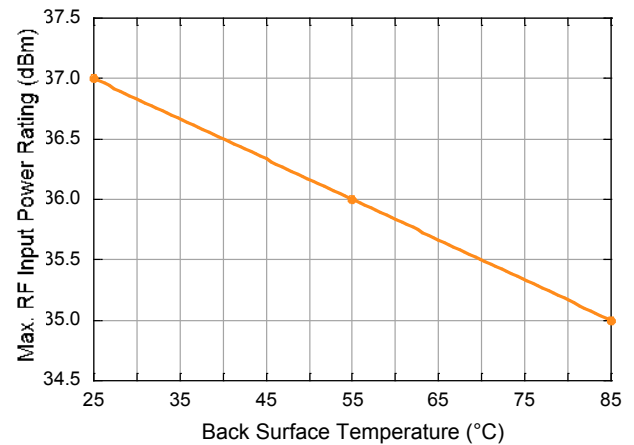

- Based on testing done at 2.2 GHz.

Handling Procedures

Please observe the following precautions to avoid damage:

Static Sensitivity

Integrated Circuits are sensitive to electrostatic discharge (ESD) and can be damaged by static electricity. Proper ESD control techniques should be used when handling these HBM class 1B devices.

Typical RF Performance

Insertion Loss



Isolation (RF to DC)



Input Return Loss

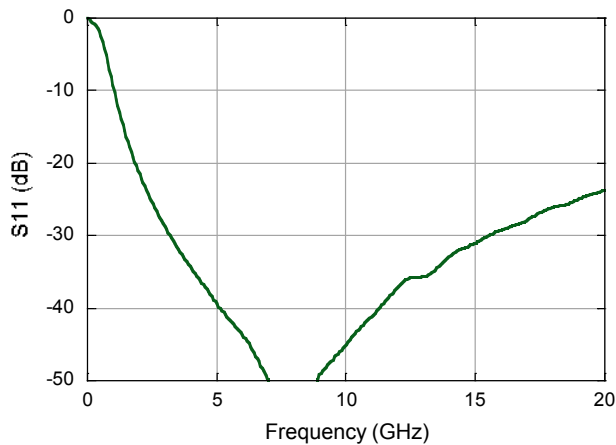

Output Return Loss

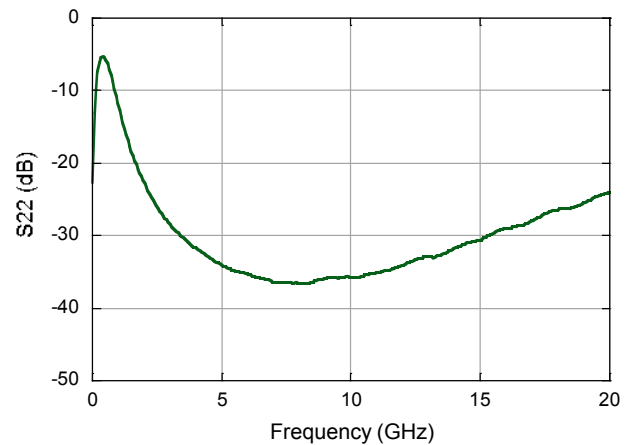

Operation

Operation of the MABT-011000 bias network is accomplished by applying DC bias to the DC port on the die. Port J2 provides the DC bias to the corresponding, connected, microwave device. Port J1 has a DC blocking capacitor, allowing current to only RF port J2, such as in a bias tee configuration. The MABT-011000 can also be used as a ground return when the DC Bias Port is attached to the RF and DC ground. The small DC resistance ($\approx 7 \Omega$) of the DC Bias Port allows up to $\pm 60 \text{ mA}$ @ $\pm 50 \text{ V}$ to be delivered while still maintaining $>35 \text{ dB}$ RF-to-DC isolation.

Handling Procedures

A vacuum pick up tool with a soft tip is recommended while placing the die. Attachment to a circuit board is made simple through the use of standard surface mount technology. Mounting pads are located on the back surface of the die. Position the die so that its mounting pads are aligned with the circuit board land pads. Since the HMIC glass is transparent, the edges of the mounting pads can be visually inspected through the die after attachment is completed.

Connections may be made onto hard or soft substrates using 80Au20Sn or other solder. When soldering these devices to a hard substrate, a solder re-flow method is preferred. When soldering to soft substrates, such as Duroid, it is recommended to choose a solder that minimizes stress due to any TCE mismatches.

Typical re-flow profiles are provided in Application Note M538, Surface Mounting Instructions, available in the Technical Resources section of the MACOM website at www.macom.com. Solder reflow should not be performed by causing heat to flow through the top surface of the die to the back surface of the die.

For applications where the average power is $\leq 1 \text{ W}$, a thermally-conductive silver epoxy may be used. Cure per manufacturers recommended time and temperature, typically 1 hour at 150°C .

Bias Circuit for PIN Diode Switch

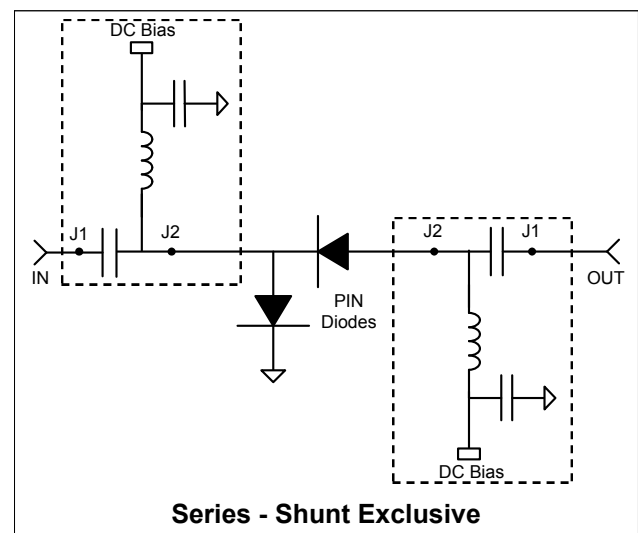
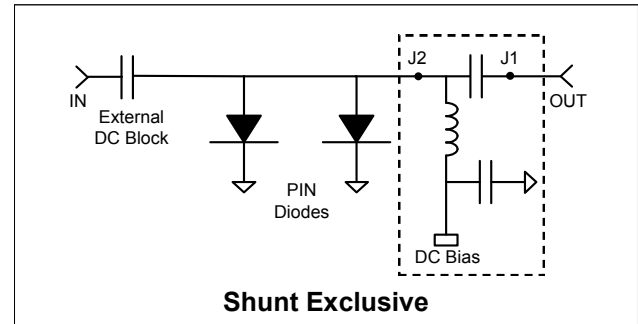

Die Outline Drawing



X-ON Electronics

Largest Supplier of Electrical and Electronic Components

Click to view similar products for [RF Wireless Misc](#) category:

Click to view products by [MACOM](#) manufacturer:

Other Similar products are found below :

[R415720000](#) [HMC598-SX](#) [RX98-4](#) [MABT-011000-14235P](#) [W2SW0001-SHLD](#) [HMC1110-SX](#) [HMC579-SX](#) [R417703118](#) [MA4BN1840-1](#)
[HMC443LP4ETR](#) [HMC561LP3ETR](#) [ADL5390ACPZ-REEL7](#) [ADA4304-2ACPZ-R2](#) [ADA4304-2ACPZ-R7](#) [ADA4304-3ACPZ-R2](#)
[ADA4304-4ACPZ-R2](#) [ADA4304-4ACPZ-R7](#) [ADA4304-3ACPZ-R7](#) [HMC760LC4B](#) [HMC577LC4B](#) [HMC370LP4E](#) [HMC443LP4E](#)
[HMC444LP4E](#) [HMC445LP4E](#) [HMC448](#) [HMC448LC3B](#) [HMC1096LP3ETR](#) [HMC573LC3BTR](#) [HMC575LP4](#) [HMC576](#) [HMC576LC3BTR](#)
[HMC578](#) [HMC578LC3B](#) [HMC578-SX](#) [HMC598](#) [HMC814](#) [HMC814LC3B](#) [HMC814LC3BTR](#) [SML1](#) [MADRCC0004](#) [MADRCC0007](#)
[MAX2045ETJ+](#) [CMX881E1](#) [SA606DK/01,118](#) [MAX1005CEE+](#) [MAX9990ETP+](#) [MADRCC0005](#) [MADRCC0006](#) [HMC448LC3BTR](#)
[CMX885Q3](#)