

GaN Amplifier 28 V, 4 W DC - 6 GHz



MAGX-011086

Rev. V4

Features

- GaN on Si HEMT D-Mode Amplifier
- Suitable for Linear & Saturated Applications
- Tunable from DC - 6 GHz
- 28 V Operation
- 9 dB Gain @ 5.8 GHz
- 45% Drain Efficiency @ 5.8 GHz
- 100% RF Tested
- Thermally-Enhanced 4 mm 24-Lead QFN
- RoHS* Compliant



Description

The MAGX-011086 is a GaN on silicon HEMT amplifier optimized for DC - 6 GHz operation in a user friendly package ideal for high bandwidth applications. The device has been designed for saturated and linear operation with output power levels of 4 W (36 dBm) in an industry standard, low inductance, surface mount QFN package. The pads of the package form a coplanar launch that naturally absorbs lead parasitics and features a small PCB outline for space constrained applications.

The MAGX-011086 is ideally suited for Wireless LAN, High Dynamic Range LNA's, broadband general purpose, land mobile radio, defense communications, wireless infrastructure, and ISM applications.

Built using the SIGANTIC® process - a proprietary GaN-on-Silicon technology.

Functional Schematic

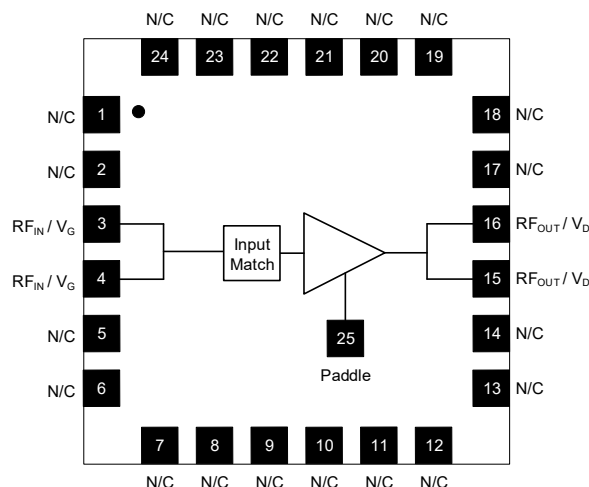

Pin Configuration²

Pin #	Pin Name	Function
1 - 2	N/C	No Connection
3 - 4	RF _{IN} / V _G	RF Input / Gate
5 - 14	N/C	No Connection
15 - 16	RF _{OUT} / V _D	RF Output / Drain
17 - 24	N/C	No Connection
25	Paddle ³	Ground / Source

Ordering Information¹

Part Number	Package
MAGX-011086	Bulk Quantity
MAGX-011086-TR0500	500 piece reel
MAGX-011086-SMB2	Sample Board

1. Reference Application Note M513 for reel size information.

2. All no connection pins may be left floating or grounded.

3. The exposed pad centered on the package bottom must be connected to RF and DC ground and provide a low thermal resistance heat path.

* Restrictions on Hazardous Substances, compliant to current RoHS EU directive.

GaN Amplifier 28 V, 4 W DC - 6 GHz



MAGX-011086

Rev. V4

RF Electrical Specifications: $T_A = 25^\circ\text{C}$, $V_{DS} = 28\text{ V}$, $I_{DQ} = 50\text{ mA}$

Parameter	Test Conditions	Symbol	Min.	Typ.	Max.	Units
Small Signal Gain	CW, 5.8 GHz	G_{SS}	-	11	-	dB
Saturated Output Power	CW, 5.8 GHz	P_{SAT}	-	37	-	dBm
Drain Efficiency at Saturation	CW, 5.8 GHz	h_{SAT}	-	50	-	%
Power Gain	5.8 GHz, $P_{OUT} = 4\text{ W}$	G_P	8	9	-	dB
Drain Efficiency	5.8 GHz, $P_{OUT} = 4\text{ W}$	h	40	45	-	%
Ruggedness: Output Mismatch	All phase angles	Y	VSWR = 10:1, No Device Damage			

DC Electrical Characteristics: $T_A = 25^\circ\text{C}$

Parameter	Test Conditions	Symbol	Min.	Typ.	Max.	Units
Drain-Source Leakage Current	$V_{GS} = -8\text{ V}$, $V_{DS} = 100\text{ V}$	I_{DLK}	-	-	2	mA
Gate-Source Leakage Current	$V_{GS} = -8\text{ V}$, $V_{DS} = 0\text{ V}$	I_{GLK}	-	-	1	mA
Gate Threshold Voltage	$V_{DS} = +28\text{ V}$, $I_D = 2\text{ mA}$	V_T	-2.5	-1.5	-0.5	V
Gate Quiescent Voltage	$V_{DS} = +28\text{ V}$, $I_D = 50\text{ mA}$	V_{GSQ}	-2.1	-1.2	-0.3	V
On Resistance	$V_{DS} = +2\text{ V}$, $I_D = 15\text{ mA}$	R_{ON}	-	2.0	-	W
Saturated Drain Current	$V_{DS} = 7\text{ V}$, Pulse Width 300 μs	$I_{D(SAT)}$	-	1.4	-	A

GaN Amplifier 28 V, 4 W DC - 6 GHz



MAGX-011086

Rev. V4

Absolute Maximum Ratings^{4,5,6}

Parameter	Absolute Max.
Drain-Source Voltage, V_{DS}	100 V
Gate-Source Voltage, V_{GS}	-10 V to 3 V
Gate Current, I_G	4 mA
Junction Temperature, T_J	+200°C
Operating Temperature	-40°C to +85°C
Storage Temperature	-65°C to +150°C

4. Exceeding any one or combination of these limits may cause permanent damage to this device.
5. MACOM does not recommend sustained operation near these survivability limits.
6. Operating at nominal conditions with $T_J \leq 200^\circ\text{C}$ will ensure $\text{MTTF} > 1 \times 10^6$ hours.

Thermal Characteristics^{7,8}

Parameter	Test Conditions	Symbol	Typ.	Units
Thermal Resistance	$V_{DS} = 28 \text{ V}, T_J = 200^\circ\text{C}$	Θ_{JC}	12.5	°C/W

7. Junction temperature (T_J) measured using IR Microscopy. Case temperature measured using thermocouple embedded in heat-sink.
8. The thermal resistance of the mounting configuration must be added to the device Θ_{JC} , for proper T_J calculation during operation. The recommended via pattern, shown on page 6, on a 20 mil thick, 1 oz. plated copper, PCB contributes an additional 6.6°C/W to the typical value.

Handling Procedures

Please observe the following precautions to avoid damage:

Static Sensitivity

Gallium Nitride Integrated Circuits are sensitive to electrostatic discharge (ESD) and can be damaged by static electricity. Proper ESD control techniques should be used when handling these class 1A devices.

GaN Amplifier 28 V, 4 W DC - 6 GHz



MAGX-011086

Rev. V4

Load-Pull Performance: $V_{DS} = 28\text{ V}$, $I_{DQ} = 50\text{ mA}$, $T_A = 25^\circ\text{C}$

Reference Plane at Device Leads, CW Drain Efficiency and Output Power Tradeoff Impedance

Frequency (MHz)	Z_S (W)	Z_L (W)	P_{SAT} (W)	G_{SS} (dB)	Drain Efficiency @ P_{SAT} (%)
900	$4.0 + j8.4$	$31.9 + j41.2$	5.8	24.6	65
2500	$4.0 - j13.1$	$12.5 + j18.0$	5.1	19.5	63
3500	$6.8 - j26.8$	$10.1 + j9.3$	5.0	57	
4000	$13.4 - j37.8$	$9.5 + j4.7$	5.0	15.3	56
5000	$67.4 - j33.2$	$8.2 + j1.2$	5.0	13.8	55
5800	$19.4 + j0.5$	$7.7 - j8.4$	5.0	12.0	55

Impedance Reference

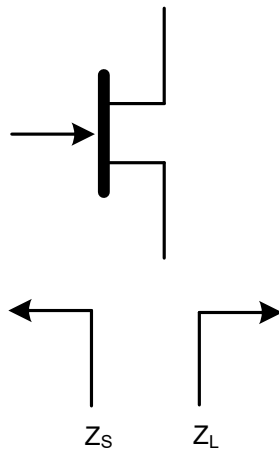

Z_S and Z_L vs. Frequency

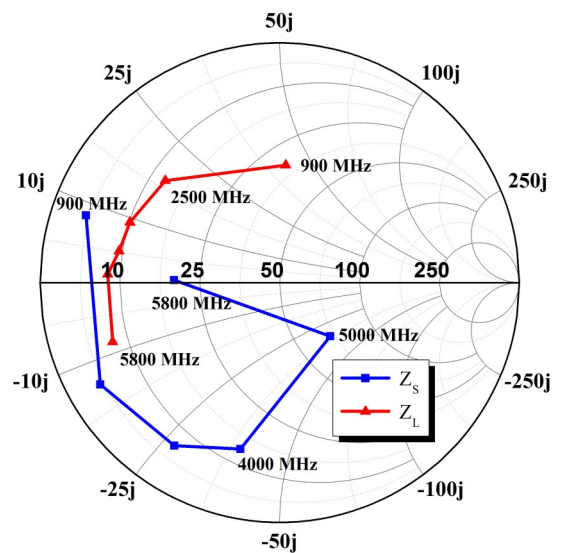

GaN Amplifier 28 V, 4 W DC - 6 GHz



MAGX-011086

Rev. V4

Load-Pull Performance: $V_{DS} = 28\text{ V}$, $I_{DQ} = 50\text{ mA}$, $T_A = 25^\circ\text{C}$
Reference Plane at Device Leads, CW Drain Efficiency and Output Power Tradeoff Impedance

Gain vs. Output Power

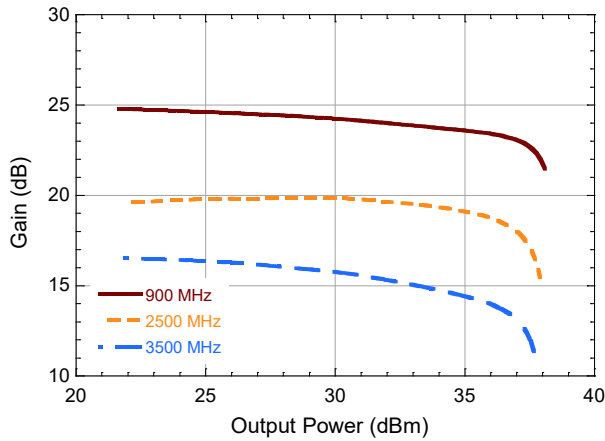

Drain Efficiency vs. Output Power

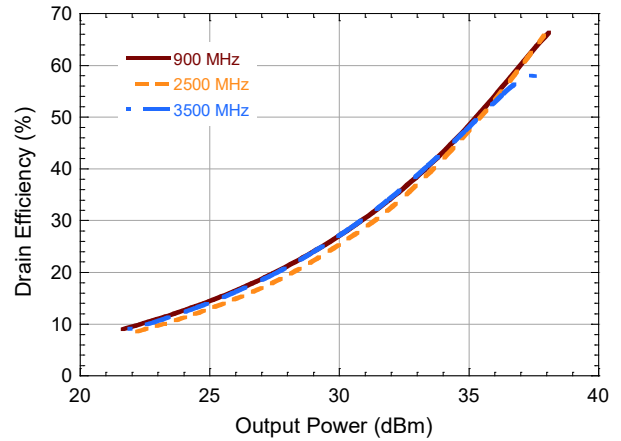

Gain vs. Output Power

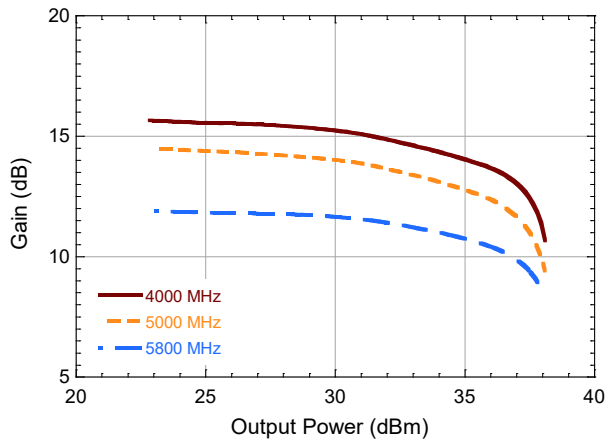

Drain Efficiency vs. Output Power

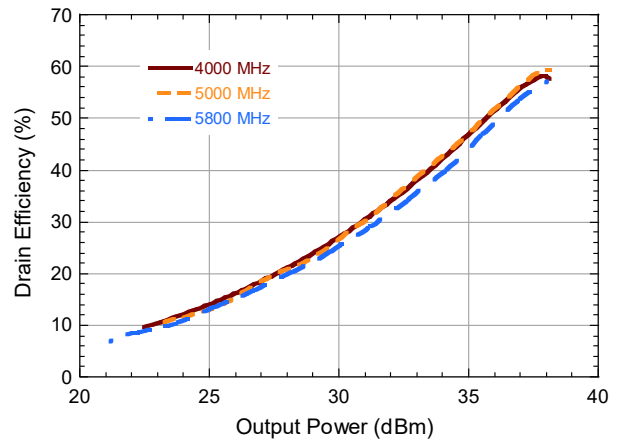

GaN Amplifier 28 V, 4 W DC - 6 GHz



MAGX-011086

Rev. V4

Evaluation Board and Recommended Tuning Solution 5.8 GHz Narrowband Circuit

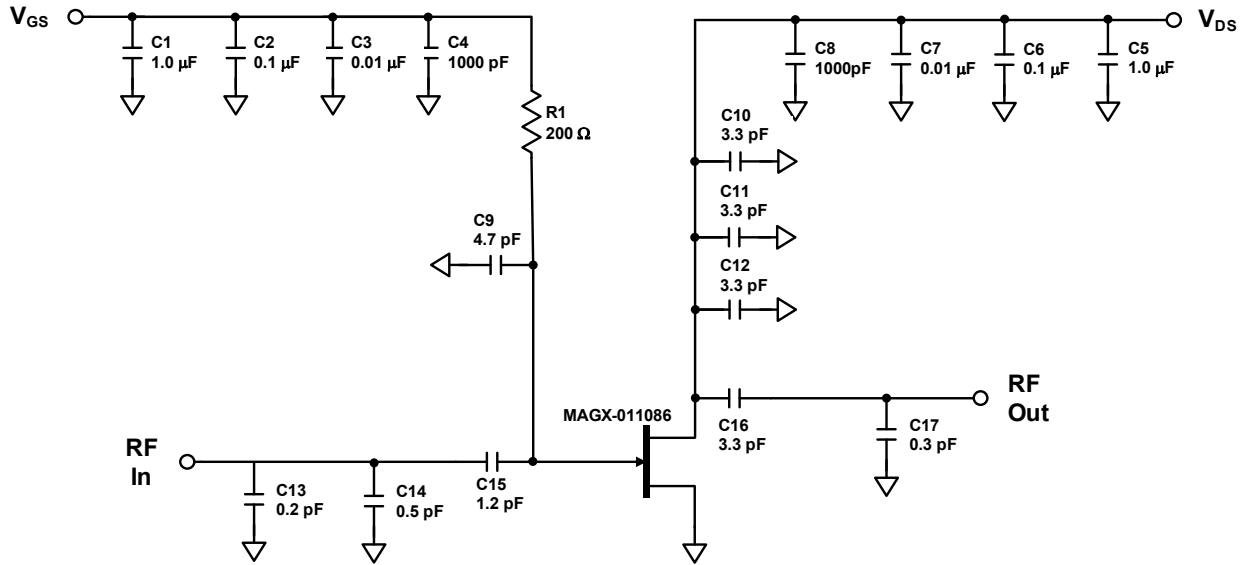

Description

Parts measured on evaluation board (20-mil thick RO4350). The PCB's electrical and thermal ground is provided using a standard-plated densely packed via hole array (see recommended via pattern).

Matching is provided using a combination of lumped elements and transmission lines as shown in the simplified schematic above. Recommended tuning solution component placement, transmission lines, and details are shown on the next page.

Bias Sequencing

Turning the device ON

1. Set V_{GS} beyond pinch-off (V_P), typically -5 V.
2. Turn on V_{DS} to nominal voltage (28 V).
3. Increase V_{GS} until the I_{DS} current is reached.
4. Apply RF power to desired level.

Turning the device OFF

1. Turn the RF power off.
2. Decrease V_{GS} down to V_P .
3. Decrease V_{DS} down to 0 V.
4. Turn off V_{GS} .

Recommended Via Pattern (All dimensions shown as inches)

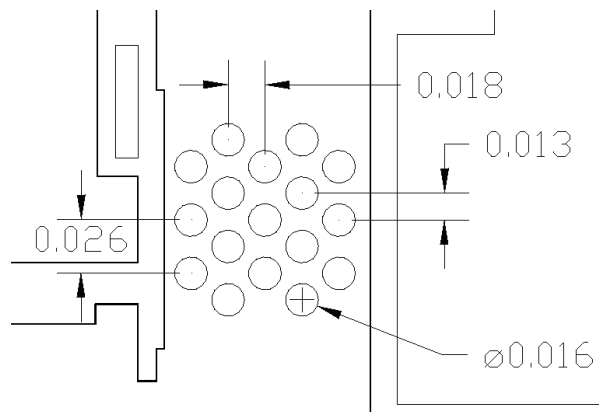

GaN Amplifier 28 V, 4 W DC - 6 GHz



MAGX-011086

Rev. V4

Evaluation Board and Recommended Tuning Solution 5.8 GHz Narrowband Circuit

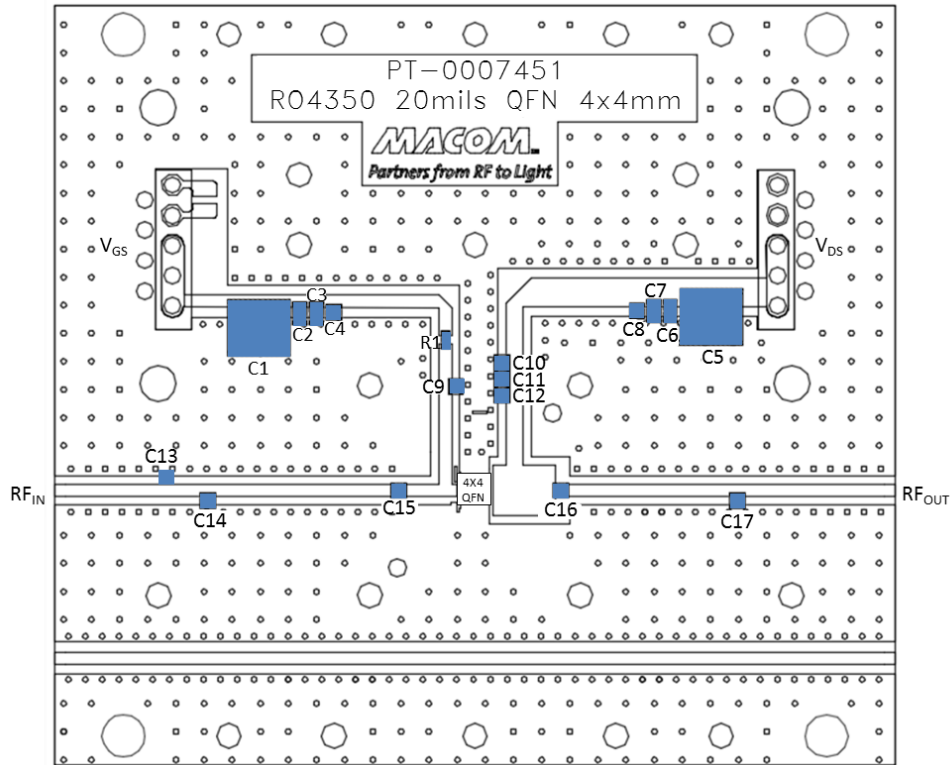

Parts list

Reference	Value	Tolerance	Manufacturer	Part Number
C1, C5	1.0 μ F	10%	AVX	12101C105KAT2A
C2, C6	0.1 μ F	10%	Kemet	C1206C104K1RACTU
C3, C7	0.01 μ F	10%	AVX	12061C103KAT2A
C4, C8	1000 pF	10%	Kemet	C0805C102K1RACTU
C9	4.7 pF	0.1 pF	ATC	ATC800A4R7B250
C10, C11, C12, C16	3.3 pF	0.1 pF	ATC	ATC800A3R3B250
C13	0.2 pF	0.1 pF	ATC	ATC800A0R2B250
C14	0.5 pF	0.1 pF	ATC	ATC800A0R5B250
C15	1.2 pF	0.1 pF	ATC	ATC800A1R2B250
C17	0.3 pF	0.1 pF	ATC	ATC800A0R3B250
R1	200 Ω	1%	Panasonic	ERJ-6ENF2000V
RF Connector	SMA	—	Amphenol-Connex	132150
DC Connector	D-Subminiature	—	ERNI	284525
PCB	RO4350	—	Rogers Corp	—

GaN Amplifier 28 V, 4 W DC - 6 GHz



MAGX-011086

Rev. V4

Typical Performance as measured in the 5.8 GHz evaluation board:
CW, $V_{DS} = 28\text{ V}$, $I_{DQ} = 50\text{ mA}$ (unless noted)

Gain vs. Output Power over Temperature

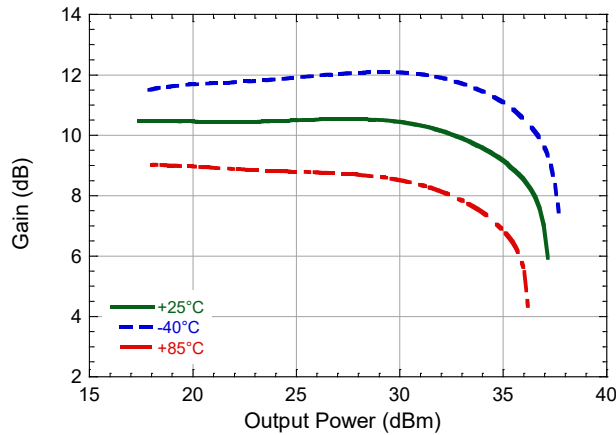

Drain Efficiency vs. Output Power over Temperature

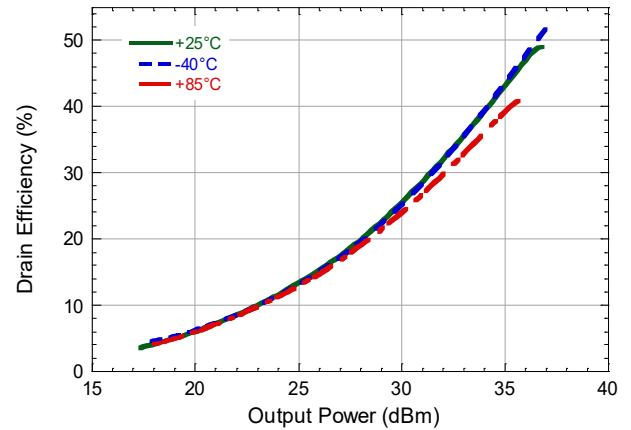

Quiescent V_{GS} vs. Temperature

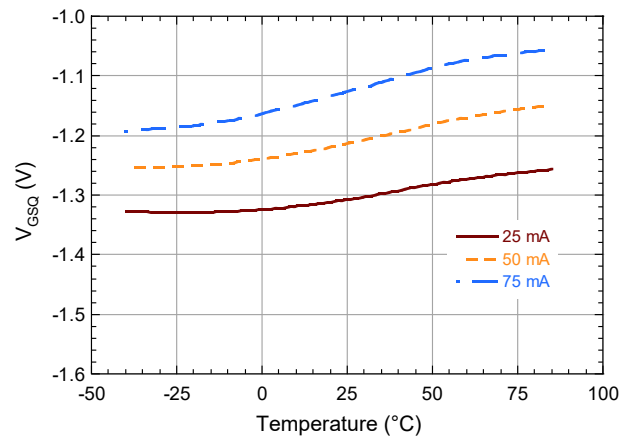

GaN Amplifier 28 V, 4 W DC - 6 GHz



MAGX-011086

Rev. V4

Typical 2-Tone Performance as measured in the 5.8 GHz evaluation board:
1 MHz Tone Spacing, $V_{DS} = 28\text{ V}$, $I_{DQ} = 50\text{ mA}$, $T_A = 25^\circ\text{C}$ (unless noted)

2-Tone IMD3 vs. Output Power vs. Quiescent Current

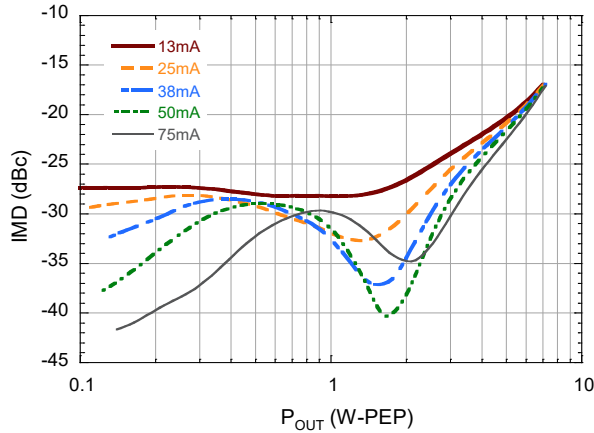

2-Tone Gain vs. Output Power vs. Quiescent Current

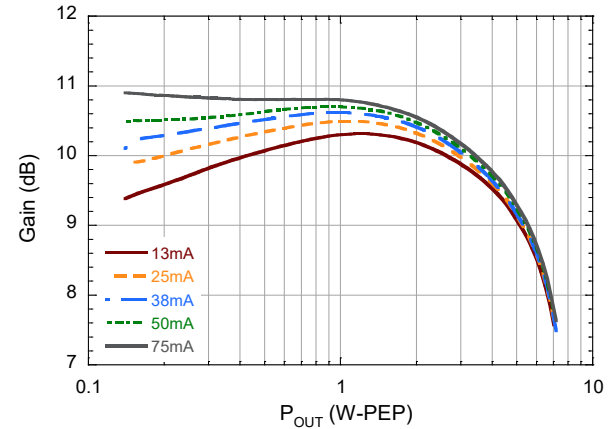

2-Tone IMD vs. Output Power

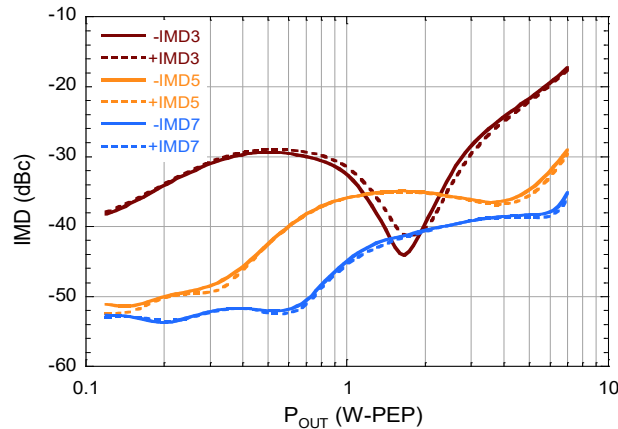

GaN Amplifier 28 V, 4 W DC - 6 GHz



MAGX-011086

Rev. V4

Lead Free 4 mm 24 Lead QFN Plastic Package[†]

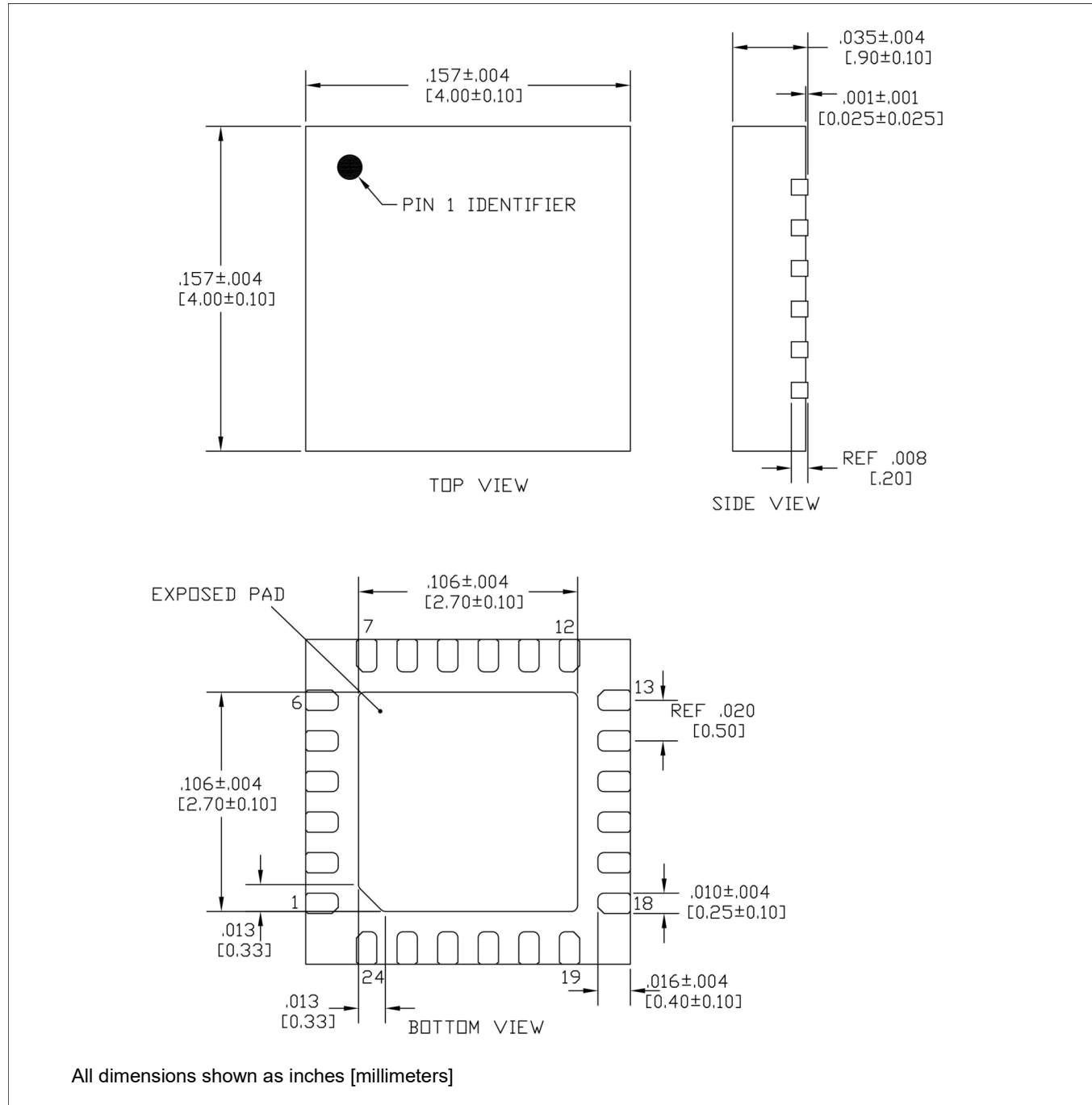

[†] Meets JEDEC moisture sensitivity level 3 requirements.
Plating is Matte Sn.

GaN Amplifier 28 V, 4 W DC - 6 GHz



MAGX-011086

Rev. V4

MACOM Technology Solutions Inc. ("MACOM"). All rights reserved.

These materials are provided in connection with MACOM's products as a service to its customers and may be used for informational purposes only. Except as provided in its Terms and Conditions of Sale or any separate agreement, MACOM assumes no liability or responsibility whatsoever, including for (i) errors or omissions in these materials; (ii) failure to update these materials; or (iii) conflicts or incompatibilities arising from future changes to specifications and product descriptions, which MACOM may make at any time, without notice. These materials grant no license, express or implied, to any intellectual property rights.

THESE MATERIALS ARE PROVIDED "AS IS" WITH NO WARRANTY OR LIABILITY, EXPRESS OR IMPLIED, RELATING TO SALE AND/OR USE OF MACOM PRODUCTS INCLUDING FITNESS FOR A PARTICULAR PURPOSE, MERCHANTABILITY, INFRINGEMENT OF INTELLECTUAL PROPERTY RIGHT, ACCURACY OR COMPLETENESS, OR SPECIAL, INDIRECT, INCIDENTAL, OR CONSEQUENTIAL DAMAGES WHICH MAY RESULT FROM USE OF THESE MATERIALS.

MACOM products are not intended for use in medical, lifesaving or life sustaining applications. MACOM customers using or selling MACOM products for use in such applications do so at their own risk and agree to fully indemnify MACOM for any damages resulting from such improper use or sale.

X-ON Electronics

Largest Supplier of Electrical and Electronic Components

Click to view similar products for [RF JFET Transistors](#) category:

Click to view products by [MACOM](#) manufacturer:

Other Similar products are found below :

[CE3514M4](#) [CE3514M4-C2](#) [CE3520K3-C1](#) [CE3521M4](#) [CE3521M4-C2](#) [CE3512K2-C1](#) [CE3520K3](#) [CG2H80030D-GP4](#) [TGF2023-2-02](#)
[NPT1004D](#) [MAGX-011086](#) [NPT25015D](#) [JANTXV2N4858](#) [CGHV27015S](#) [NPT2021](#) [NPTB00025B](#) [TGF2965-SM](#) [QPD1009](#) [QPD1010](#)
[2SK3557-6-TB-E](#) [J211_D74Z](#) [NPTB00004A](#) [MMBFJ211](#) [QPD0005TR13](#) [QPD0020](#) [QPD1006](#) [QPD1016](#) [QPD1025L](#) [QPD1029L](#)
[QPD1881L](#) [T2G6001528-Q3](#) [SKY65050-372LF](#) [J304](#) [CGH27015F](#) [CGH27060F](#) [CGH55015F1](#) [CMPA801B030F](#) [GTVA262711FA-V2-R0](#)
[GTVA262701FA-V2-R0](#) [CGH40006S](#) [CGH40010F](#) [CGH40025F](#) [CGH40045F](#) [CGH40120F](#) [CGH40180PP](#) [CGH55015F2](#) [CGH60008D](#)
[CGH60030D](#) [CGHV14500F](#) [CGHV1F006S](#)