

# GaN Amplifier 50 V, 50 W

## DC - 2700 MHz



MAGX-100027-050C0P

Rev. V3

### Features

- Optimized for a Multitude of Applications
- CW and Pulsed Operation: 50 W Output Power
- Internally Pre-matched
- 260°C Reflow Compatible
- 50 V Operation
- 100% RF Tested
- RoHS\* Compliant



TO-272S-2

### Description

The MAGX-100027-050C0P is a high power GaN on Silicon HEMT D-mode amplifier optimized for DC - 2700 MHz frequency operation. The device supports both CW and pulsed operation with peak output power levels to 50 W (47 dBm) in a plastic package.

The MAGX-100027-050C0P is ideally suited for a multitude of applications including military radio communications, digital cellular infrastructure, RF energy, avionics, test instrumentation and RADAR.

### Typical Performance:

- $V_{DS} = 50\text{ V}$ ,  $I_{DQ} = 100\text{ mA}$ ,  $T_C = 25^\circ\text{C}$ .  
Measured under pulsed load-pull at optimum efficiency load impedance, 2.0 dB Compression, 100µs pulse width, 1ms period, 10% duty cycle

Frequency (MHz)	Output Power (dBm)	Gain (dB)	$\eta_D$ (%)
650	47.6	27.1	79.1
950	45.6	24.5	79.5
1200	47.9	22.4	79.7
1600	48.3	19.8	76.3
2000	48.3	19.1	75.4
2400	47.6	18.5	76.5

### Functional Schematic

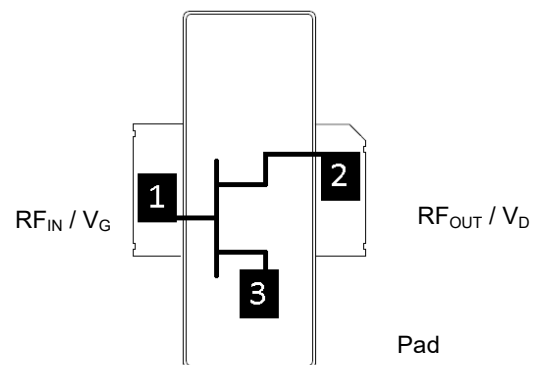

### Pin Configuration

Pin #	Pin Name	Function
1	RF <sub>IN</sub> / V <sub>G</sub>	RF Input / Gate
2	RF <sub>OUT</sub> / V <sub>D</sub>	RF Output / Drain
3	Pad <sup>1</sup>	Ground / Source

1. The exposed pad centered on the package bottom must be connected to RF, DC and thermal ground.

### Ordering Information

Part Number	Package
MAGX-100027-050C0P	Bulk Quantity
MAGX-100027-050CTP	Tape and Reel
MAGX-1A0027-050C0P	Sample Board

\* Restrictions on Hazardous Substances, compliant to current RoHS EU directive.

# GaN Amplifier 50 V, 50 W DC - 2700 MHz



MAGX-100027-050C0P

Rev. V3

## RF Electrical Characteristics: $T_C = 25^\circ\text{C}$ , $V_{DS} = 50\text{ V}$ , $I_{DQ} = 100\text{ mA}$

Note: Performance in MACOM Application Fixture (2400 - 2500 MHz), 50  $\Omega$  system

Parameter	Test Conditions	Symbol	Min.	Typ.	Max.	Units
Small Signal Gain	CW, 2500 MHz	$G_{SS}$	-	18.8	-	dB
Power Gain	CW, 2500 MHz, 2 dB Gain Compression	$G_{SAT}$	-	16.8	-	dB
Saturated Drain Efficiency	CW, 2500 MHz, 2 dB Gain Compression	$\eta_{SAT}$	-	72	-	%
Saturated Output Power	CW, 2500 MHz, 2 dB Gain Compression	$P_{SAT}$	-	48.4	-	dBm
Gain Variation (-25°C to +85°C)	Pulsed <sup>2</sup> , 2500 MHz	$\Delta G$	-	0.02	-	dB/°C
Power Variation (-25°C to +85°C)	Pulsed <sup>2</sup> , 2500 MHz	$\Delta P_{2dB}$	-	0.004	-	dB/°C
Gain	CW, 2500 MHz, $P_{IN} = 32\text{ dBm}$	$G_P$	-	16.8	-	dB
Drain Efficiency	CW, 2500 MHz, $P_{IN} = 32\text{ dBm}$	$\eta$	-	72	-	%
Ruggedness: Output Mismatch	All phase angles	$\Psi$	VSWR = 10:1, No Device Damage			

## RF Electrical Specifications: $T_A = 25^\circ\text{C}$ , $V_{DS} = 50\text{ V}$ , $I_{DQ} = 100\text{ mA}$

Note: Performance in MACOM Production Test Fixture, 50  $\Omega$  system

Parameter	Test Conditions	Symbol	Min.	Typ.	Max.	Units
Power Gain	CW, 2500 MHz, 2 dB Gain Compression	$G_{SAT}$	14	15.3	-	dB
Saturated Drain Efficiency	CW, 2500 MHz, 2 dB Gain Compression	$\eta_{SAT}$	60	67.5	-	%
Saturated Output Power	CW, 2500 MHz, 2 dB Gain Compression	$P_{SAT}$	48	49.4	-	dBm
Gain	CW, 2500 MHz, $P_{IN} = 33\text{ dBm}$	$G_P$	15	16	-	dB
Drain Efficiency	CW, 2500 MHz, $P_{IN} = 33\text{ dBm}$	$\eta$	58	65	-	%

2. Pulse details: 100  $\mu\text{s}$  pulse width, 1 ms period, 10% Duty Cycle

DC Electrical Characteristics  $T_A = 25^\circ\text{C}$

Parameter	Test Conditions	Symbol	Min.	Typ.	Max.	Units
Drain-Source Leakage Current	$V_{GS} = -8\text{ V}, V_{DS} = 130\text{ V}$	$I_{DLK}$	-	-	10.8	mA
Gate-Source Leakage Current	$V_{GS} = -8\text{ V}, V_{DS} = 0\text{ V}$	$I_{GLK}$	-	-	10.8	mA
Gate Threshold Voltage	$V_{DS} = 50\text{ V}, I_D = 10.8\text{ mA}$	$V_T$	-2.6	-2.0	-1.6	V
Gate Quiescent Voltage	$V_{DS} = 50\text{ V}, I_D = 250\text{ mA}$	$V_{GSQ}$	-2.4	-1.8	-1.4	V
On Resistance	$V_{GS} = 2\text{ V}, I_D = 80\text{ mA}$	$R_{ON}$	-	0.44	-	$\Omega$
Maximum Drain Current	$V_{DS} = 7\text{ V}$ pulsed, pulse width 300 $\mu\text{s}$	$I_{D, MAX}$	-	6.3	-	A

**Absolute Maximum Ratings**<sup>3,4,5,6,7</sup>

Parameter	Absolute Maximum
Drain Source Voltage, $V_{DS}$	130 V
Gate Source Voltage, $V_{GS}$	-10 to 3 V
Gate Current, $I_G$	10 mA
Storage Temperature Range	-65°C to +150°C
Case Operating Temperature Range	-40°C to +120°C
Channel Operating Temperature Range, $T_{CH}$	-40°C to +225°C
Absolute Maximum Channel Temperature	+250°C

3. Exceeding any one or combination of these limits may cause permanent damage to this device.
4. MACOM does not recommend sustained operation above maximum operating conditions.
5. Operating at drain source voltage  $V_{DS} < 55$  V will ensure  $MTTF > 1 \times 10^7$  hours.
6. Operating at nominal conditions with  $T_{CH} \leq 225^\circ\text{C}$  will ensure  $MTTF > 1 \times 10^7$  hours.
7.  $MTTF$  may be estimated by the expression  $MTTF \text{ (hours)} = A e^{[B + C/(T+273)]}$  where  $T$  is the channel temperature in degrees Celsius,  $A = 3.686$ ,  $B = -35.00$ , and  $C = 25,416$ .

**Thermal Characteristics**<sup>8</sup>

Parameter	Test Conditions	Symbol	Typical	Units
Thermal Resistance using Finite Element Analysis	$V_{DS} = 50$ V, $P_D = 30$ W, $T_C = 85^\circ\text{C}$ , $T_{CH} = 225^\circ\text{C}$	$R_{\theta}(\text{FEA})$	3.3	°C/W
Thermal Resistance using Infrared Measurement of Die Surface Temperature	$V_{DS} = 50$ V, $P_D = 30$ W, $T_C = 85^\circ\text{C}$ , $T_{CH} = 225^\circ\text{C}$	$R_{\theta}(\text{IR})$	2.76	°C/W

8. Case temperature measured using thermocouple embedded in heat-sink. Contact local applications support team for more details on this measurement.

**Handling Procedures**

Please observe the following precautions to avoid damage:

**Static Sensitivity**

Gallium Nitride Circuits are sensitive to electrostatic discharge (ESD) and can be damaged by static electricity. Proper ESD control techniques should be used when handling these HBM Class 1B, CDM Class C3 devices.

**Application Fixture 2400 - 2500 MHz**

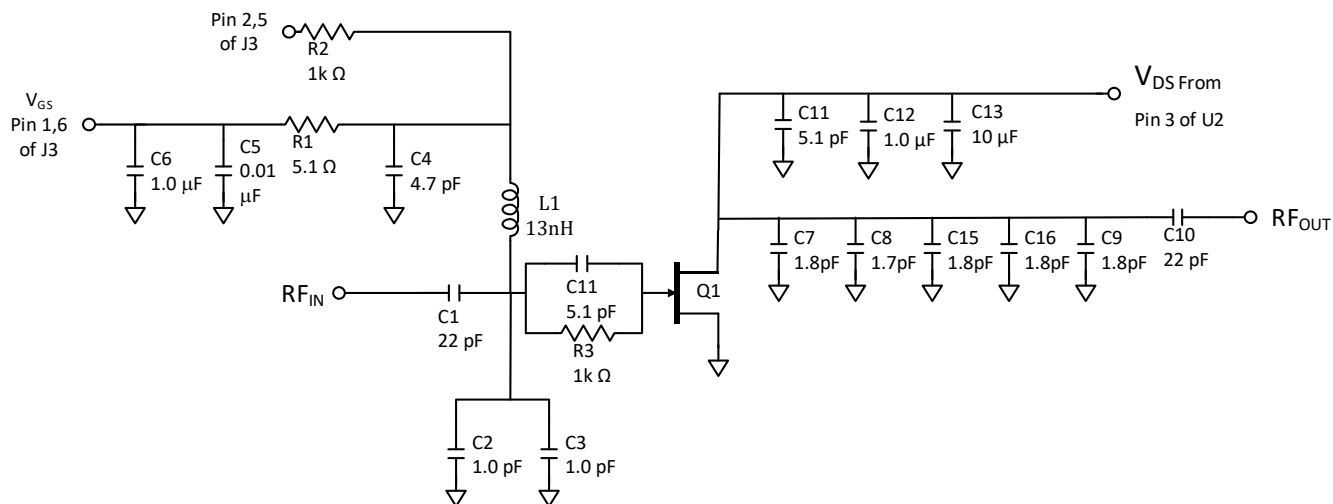

**Description**

Parts measured on application board (20-mil thick RF35A2). Matching is provided using a combination of lumped elements and transmission lines as shown in the simplified schematic above. Recommended tuning solution component placement, transmission lines, and details are shown on the next page.

**Bias Sequencing**

**Turning the device ON**

1. Set  $V_{GS}$  to pinch-off ( $V_P$ ).
2. Turn on  $V_{DS}$  to nominal voltage (50 V).
3. Increase  $V_{GS}$  until  $I_{DS}$  current is reached.
4. Apply RF power to desired level.

**Turning the device OFF**

1. Turn the RF power off.
2. Decrease  $V_{GS}$  down to  $V_P$  pinch-off.
3. Decrease  $V_{DS}$  down to 0 V.
4. Turn off  $V_{GS}$ .

Application Fixture 2400 - 2500 MHz

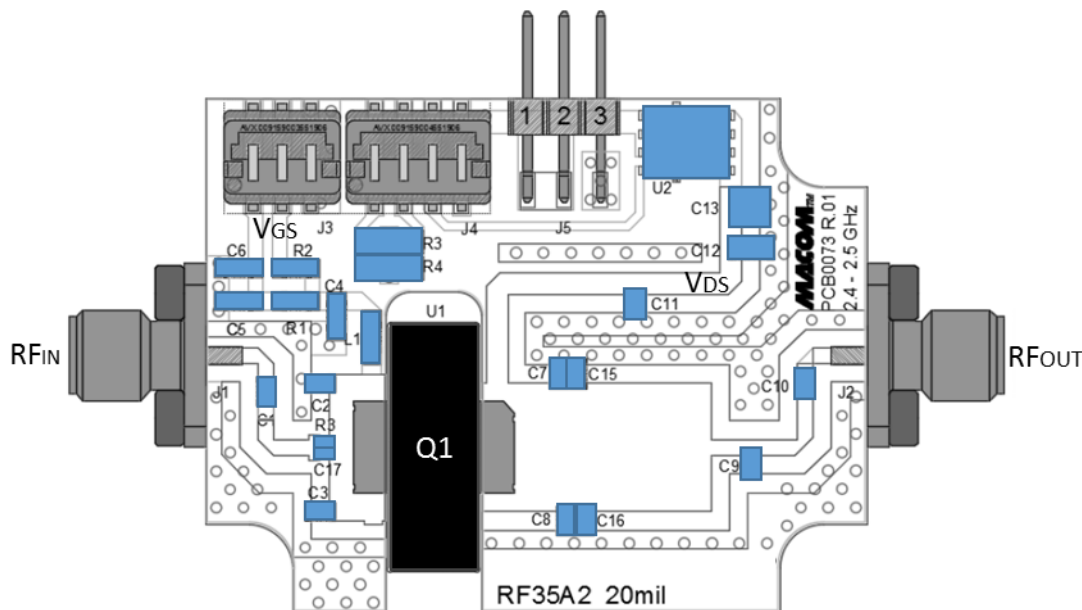

Parts List

Reference Designator	Value	Tolerance	Manufacturer	Part Number
C1, C10	22 pF	+/-5%	Passive Plus	0805N220JW251T
C2, C3	1.0 pF	+/-0.1 pF	Passive Plus	0805N1R0BW251T
C4	4.7 pF	+/-0.1 pF	Passive Plus	0805N4R7BW251T
C5	0.01 $\mu$ F	10%	Murata	GRM219R7YA103KA12D
C6	1 $\mu$ F	10%	Murata	GRM219R7YA105KA12D
C7, C15, C16	1.8 pF	+/-0.1 pF	Passive Plus	0805N1R8BW251T
C8	1.7 pF	+/-0.1 pF	Passive Plus	0805N1R7BW251T
C9	1.8 pF	+/-0.1 pF	Passive Plus	0805N1R8BW251T
C11	5.1 pF	+/-0.1 pF	Passive Plus	0805N5R1BW251T
C12	1 $\mu$ F	10%	Murata	GRM31CR72A105K
C13	10 $\mu$ F	20%	Murata	GRM32ER71J106MA12
C17	6.8 pF	+/-0.1 pF	Passive Plus	0603N6R8BW251T
L1	12 nH	5%	Coilcraft	0805HQ-12NXGLB
R1	5.1 $\Omega$	+/-1%	VIKING	CR-05FLF---5R1
R2	1 k $\Omega$	5%	VIKING	CR-05FLF----1K
R3	5.1 $\Omega$	+/-1%	VIKING	CR-03FLF---5R1
U2	80-V	-	MACOM	Si7469DP
Q1	50 W	-	MACOM	MAGX-100027-050C0P
PCB	Taconic RF35A2, 20 mil, 1 oz. Cu, Au Finish			

**Typical Performance Curves as Measured in the 2400 - 2500 MHz Application Fixture:**  
**CW, 2.45 GHz,  $V_{DS} = 50$  V,  $I_{DQ} = 100$  mA,  $T_C = 25^\circ\text{C}$**   
**Unless Otherwise Noted**

**Gain and Drain Efficiency vs. Output Power and Frequency**

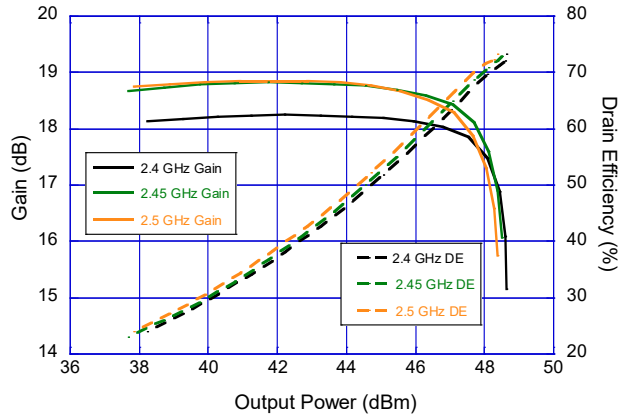

**Performance vs. Frequency at Fixed  $P_{IN} = 32$  dBm**

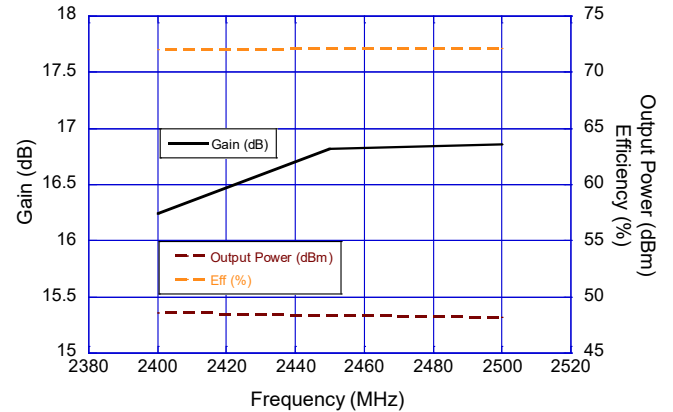

**Gain and Drain Efficiency vs. Output Power and  $T_C$**

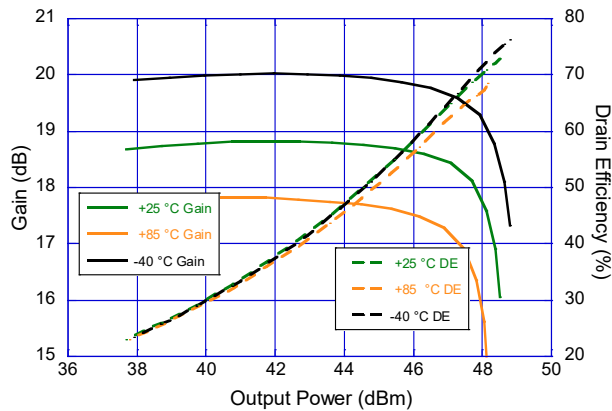

**Gain and Drain Efficiency vs. Output Power and  $I_{DQ}$**

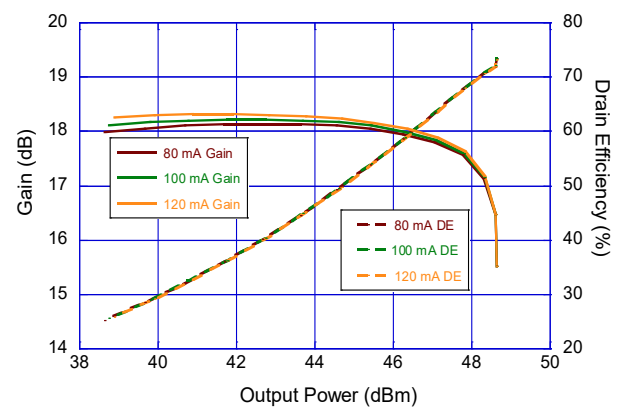

**Gain vs. Output Power and  $V_{DS}$**

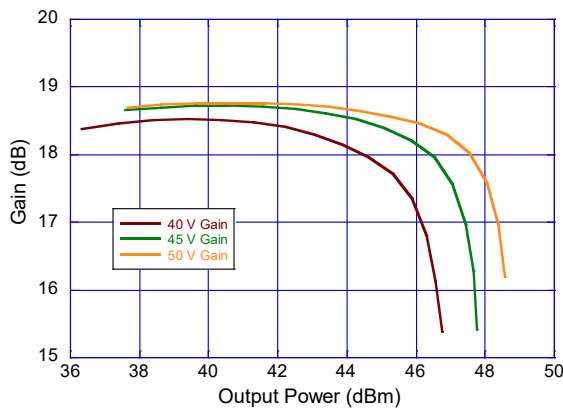

**Drain Efficiency vs. Output Power and  $V_{DS}$**

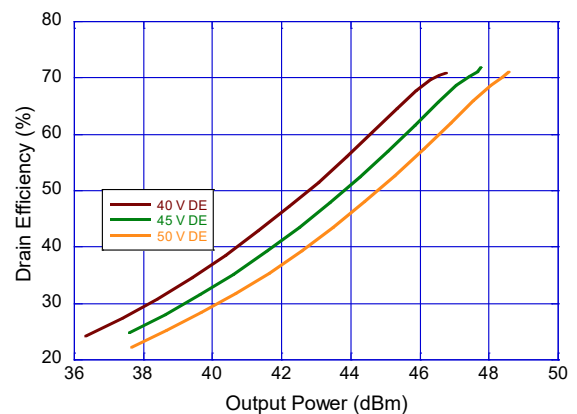

MAGX-1A0027-050C0P Sample Board 500 - 2500 MHz

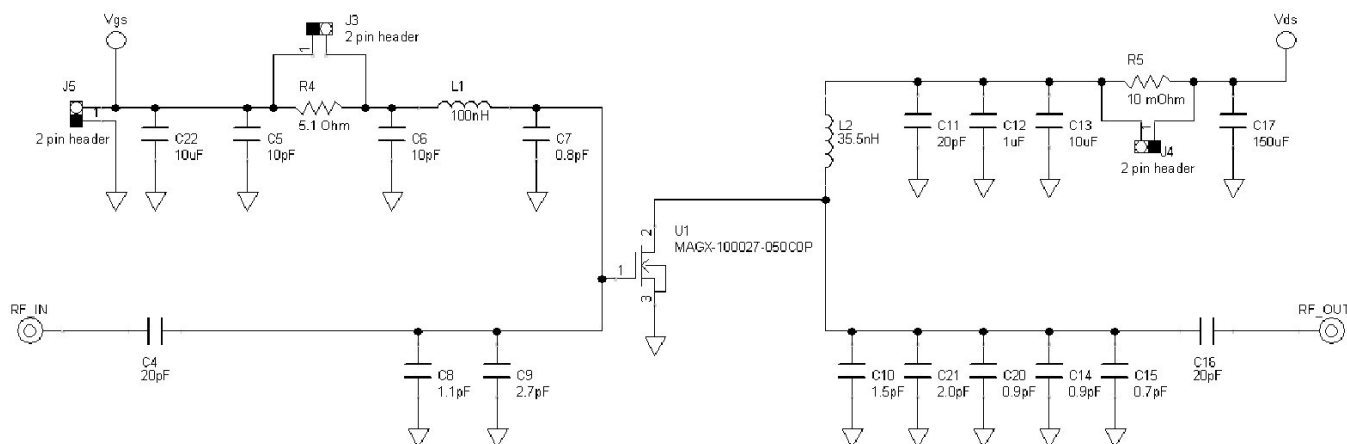

**Description**

Parts measured on sample board (RO4350, 20-mil thick input, 30-mil thick output). Matching is provided using a combination of lumped elements and transmission lines as shown in the simplified schematic above. Recommended tuning solution component placement, transmission lines, and details are shown on the next page.

**Bias Sequencing**

**Turning the device ON**

1. Set  $V_{GS}$  to pinch-off ( $V_P$ ).
2. Turn on  $V_{DS}$  to nominal voltage (50 V).
3. Increase  $V_{GS}$  until  $I_{DS}$  current is reached.
4. Apply RF power to desired level.

**Turning the device OFF**

1. Turn the RF power off.
2. Decrease  $V_{GS}$  down to  $V_P$  pinch-off.
3. Decrease  $V_{DS}$  down to 0 V.
4. Turn off  $V_{GS}$ .



MAGX-1A0027-050C0P Sample Board 500 - 2500 MHz

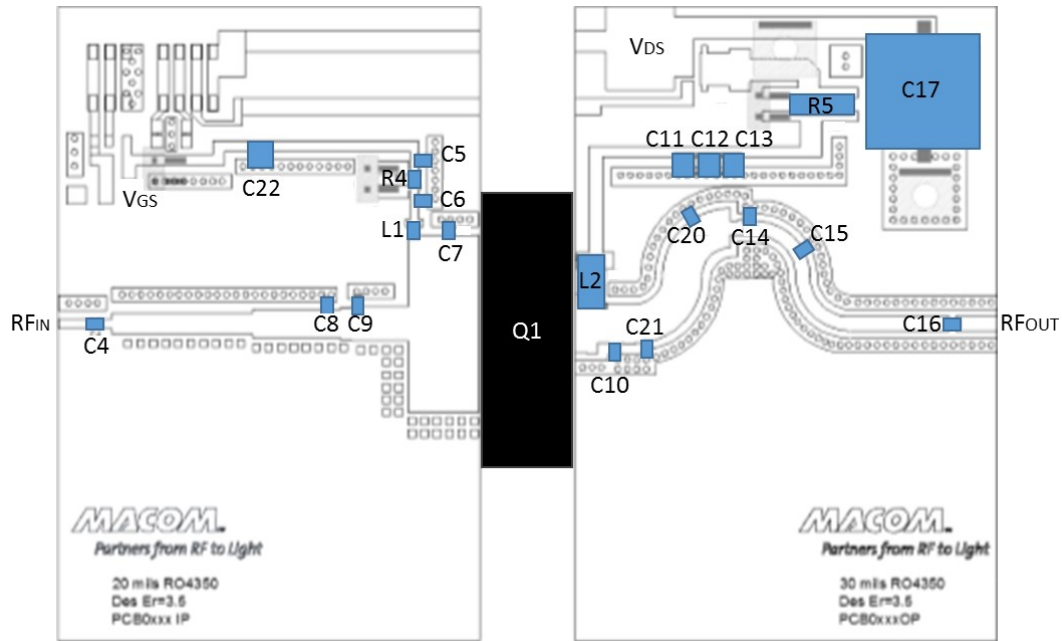

Parts List

Reference Designator	Value	Tolerance	Manufacturer	Part Number
C4, C16	20 pF	+/-0.1pF	Passive Plus	0805N200JW251T
C5, C6	10 pF	+5%	Passive Plus	0805N100JW251T
C7	0.8 pF	+/-0.1pF	Passive Plus	0805N0R8BW251T
C8	1.1 pF	+/-0.1pF	Passive Plus	0805N1R1BW251T
C9	2.7 pF	+/-0.1pF	Passive Plus	0805N2R7BW251T
C10	1.5 pF	+/-0.1pF	Passive Plus	0805N1R5BW251T
C11	20 pF	5%	Passive Plus	1111N200JW251T
C12	1 μF	10%	Murata	GRM32ER72A105K
C13, C22	10 μF	10%	Murata	GRM32DF51H106ZA01L
C14, C20	0.9 pF	+/-0.1pF	Passive Plus	0805N0R9BW251T
C15	0.7 pF	+/-0.1pF	Passive Plus	0805N0R7BW251T
C17	150 μF	20%	Panasonic	EEV-FK1K151Q
C21	2 pF	+/-0.1pF	Passive Plus	0805N2R0BW251T
L1	100 nH	5%	Coilcraft	0805CS-101
L2	35.5 nH	5%	Coilcraft	B09T
R4	5.1 Ω	+/-1%	VIKING	CR-05FL7---5R1
R5	10 mΩ	+/-1%	VIKING	CS75FTFR010
Q1	MACOM GaN Power Amplifier			MAGX-100027-050C0P
PCB	RO4350, 20mil, 1oz Cu, Au Finish (input) RO4350, 30mil, 1oz Cu Au Finish (output)			

**Typical Performance Curves as Measured in the 500 - 2500 MHz Application Fixture:  
Pulsed<sup>2</sup>, 2.4 GHz,  $V_{DS} = 50$  V,  $I_{DQ} = 100$  mA,  $T_C = 25^\circ\text{C}$   
Unless Otherwise Noted**

**Gain and Drain Efficiency vs. Output Power and Frequency**

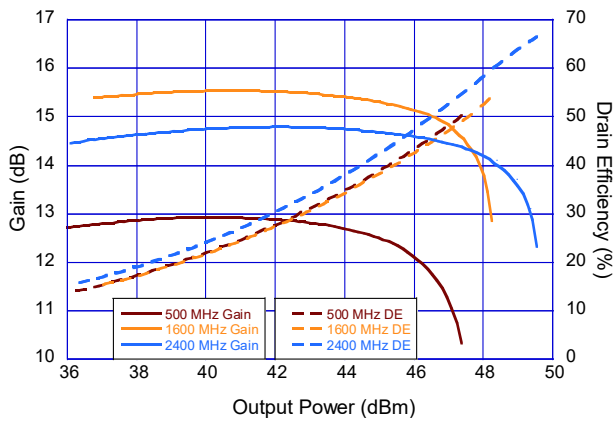

**Performance vs. Frequency at  $T_C = 25^\circ\text{C}$**

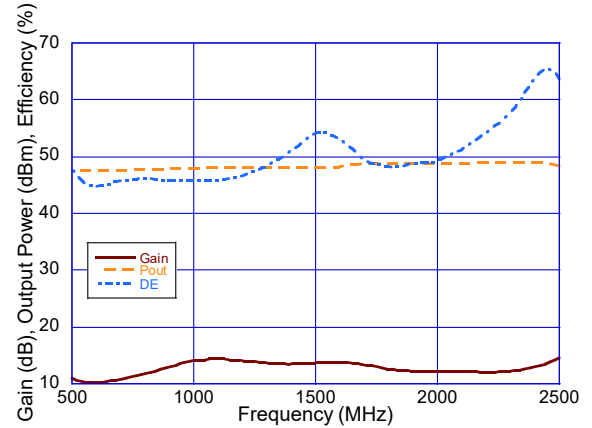

**Output Power vs. Frequency and  $T_C$**

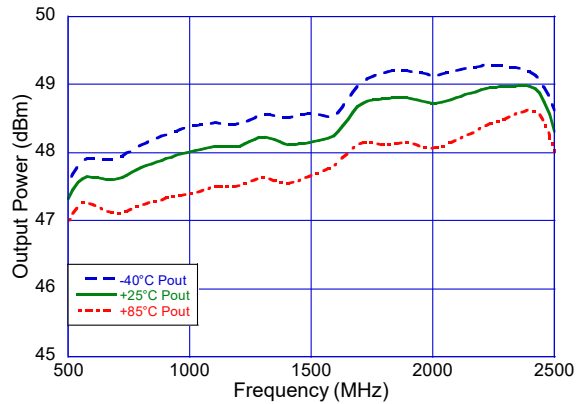

**Drain Efficiency vs. Frequency and  $T_C$**

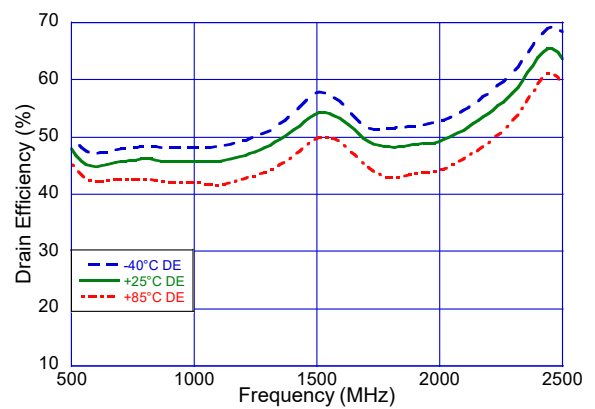

**Gain and Drain Efficiency vs. Output Power and  $T_C$**

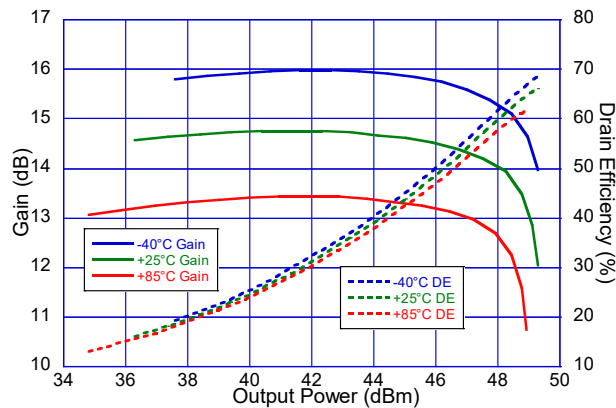

**Lead-Free TO-272S-2 Package Dimensions<sup>†</sup>**

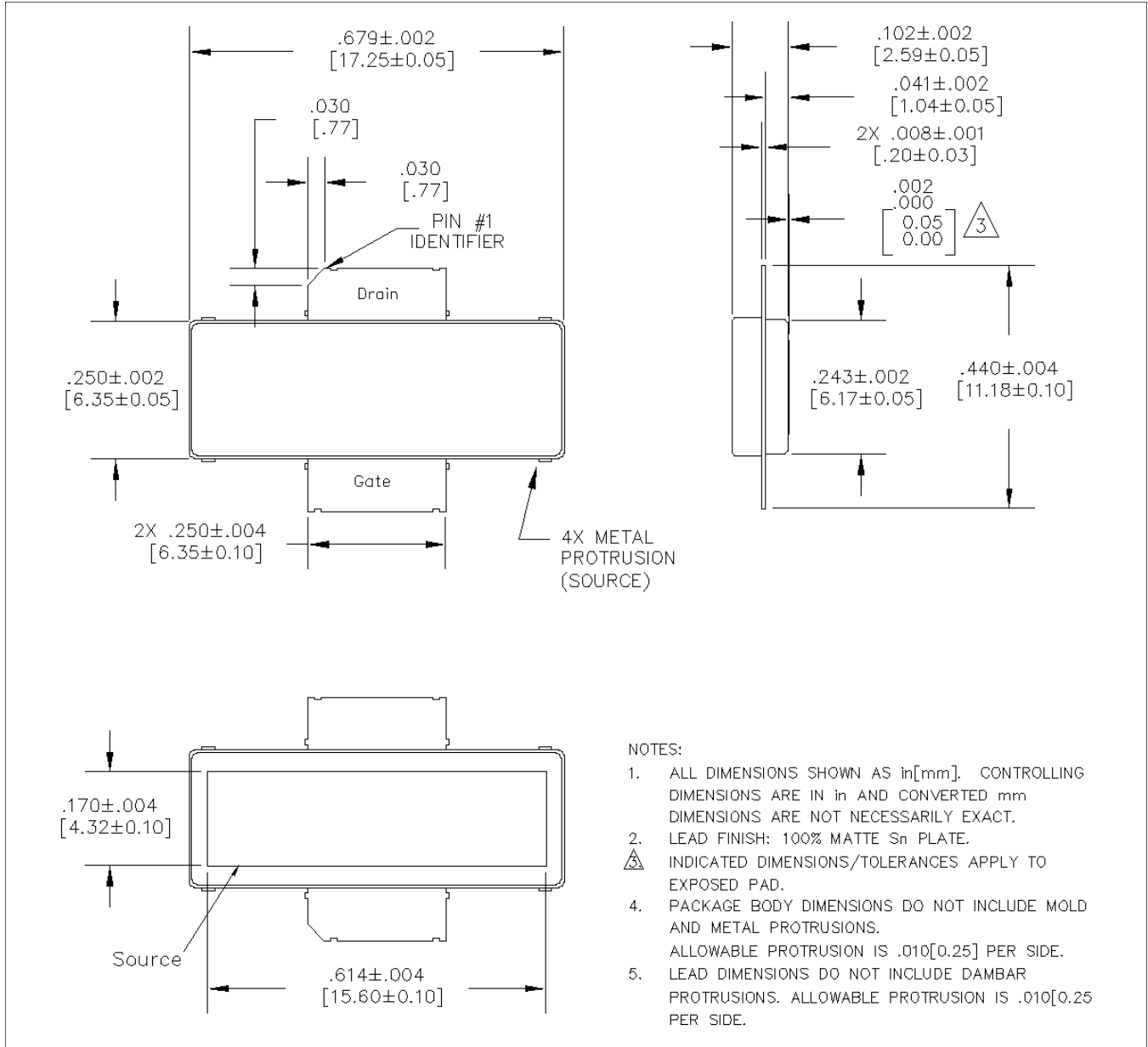

NOTES:

1. ALL DIMENSIONS SHOWN AS in[mm]. CONTROLLING DIMENSIONS ARE IN IN AND CONVERTED mm DIMENSIONS ARE NOT NECESSARILY EXACT.
2. LEAD FINISH: 100% MATTE Sn PLATE.
3.  $\triangle$  INDICATED DIMENSIONS/TOLERANCES APPLY TO EXPOSED PAD.
4. PACKAGE BODY DIMENSIONS DO NOT INCLUDE MOLD AND METAL PROTRUSIONS. ALLOWABLE PROTRUSION IS .010[0.25] PER SIDE.
5. LEAD DIMENSIONS DO NOT INCLUDE DAMBAR PROTRUSIONS. ALLOWABLE PROTRUSION IS .010[0.25] PER SIDE.

<sup>†</sup> Reference Application Note AN0004125 for lead-free solder reflow recommendations.  
Meets JEDEC moisture sensitivity level 3 requirements.  
Plating is Matte Sn.

MACOM Technology Solutions Inc. ("MACOM"). All rights reserved.

These materials are provided in connection with MACOM's products as a service to its customers and may be used for informational purposes only. Except as provided in its Terms and Conditions of Sale or any separate agreement, MACOM assumes no liability or responsibility whatsoever, including for (i) errors or omissions in these materials; (ii) failure to update these materials; or (iii) conflicts or incompatibilities arising from future changes to specifications and product descriptions, which MACOM may make at any time, without notice. These materials grant no license, express or implied, to any intellectual property rights.

THESE MATERIALS ARE PROVIDED "AS IS" WITH NO WARRANTY OR LIABILITY, EXPRESS OR IMPLIED, RELATING TO SALE AND/OR USE OF MACOM PRODUCTS INCLUDING FITNESS FOR A PARTICULAR PURPOSE, MERCHANTABILITY, INFRINGEMENT OF INTELLECTUAL PROPERTY RIGHT, ACCURACY OR COMPLETENESS, OR SPECIAL, INDIRECT, INCIDENTAL, OR CONSEQUENTIAL DAMAGES WHICH MAY RESULT FROM USE OF THESE MATERIALS.

MACOM products are not intended for use in medical, lifesaving or life sustaining applications. MACOM customers using or selling MACOM products for use in such applications do so at their own risk and agree to fully indemnify MACOM for any damages resulting from such improper use or sale.

## X-ON Electronics

Largest Supplier of Electrical and Electronic Components

*Click to view similar products for [RF Amplifier](#) category:*

*Click to view products by [MACOM](#) manufacturer:*

Other Similar products are found below :

[A82-1](#) [BGA622H6820XTSA1](#) [BGA 728L7 E6327](#) [BGB719N7ESDE6327XTMA1](#) [HMC397-SX](#) [HMC405](#) [HMC561-SX](#) [HMC8120-SX](#)  
[HMC8121-SX](#) [HMC-ALH382-SX](#) [HMC-ALH476-SX](#) [SE2433T-R](#) [SMA3101-TL-E](#) [SMA39](#) [A66-1](#) [A66-3](#) [A67-1](#) [LX5535LQ](#) [LX5540LL](#)  
[MAAM02350](#) [HMC3653LP3BETR](#) [HMC549MS8GETR](#) [HMC-ALH435-SX](#) [SMA101](#) [SMA32](#) [SMA411](#) [SMA531](#) [SST12LP17E-XX8E](#)  
[SST12LP19E-QX6E](#) [WPM0510A](#) [HMC5929LS6TR](#) [HMC5879LS7TR](#) [HMC1126](#) [HMC1087F10](#) [HMC1086](#) [HMC1016](#) [SMA1212](#)  
[MAX2689EWS+T](#) [MAAMSS0041TR](#) [MAAM37000-A1G](#) [LTC6430AIUF-15#PBF](#) [CHA5115-QDG](#) [SMA70-2](#) [SMA4011](#) [A231](#) [HMC-](#)  
[AUH232](#) [LX5511LQ](#) [LX5511LQ-TR](#) [HMC7441-SX](#) [HMC-ALH310](#)