

## The RF Line Controlled “Q” Broadband Power Transistor 100W, 30 to 500MHz, 28V

Rev. V1

Designed primarily for wideband large-signal output and driver amplifier stages in the 30 to 500 MHz frequency range.

- Specified 28 V, 500 MHz characteristics —  
Output power = 100 W  
Typical gain = 9.5 dB (Class AB); 8.5 dB (Class C)  
Efficiency = 55% (typ.)
- Built-in input impedance matching networks for broadband operation
- Push-pull configuration reduces even numbered harmonics
- Gold metallization system for high reliability
- 100% tested for load mismatch

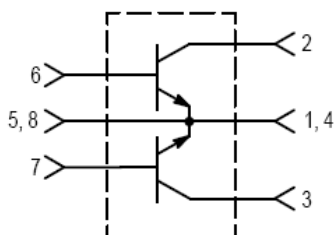

### Product Image

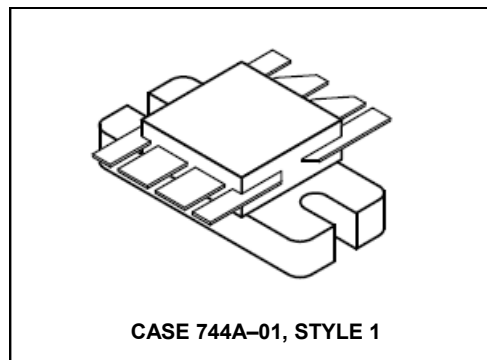

The MRF393 is two transistors in a single package with separate base and collector leads and emitters common. This arrangement provides the designer with a space saving device capable of operation in a push-pull configuration.

### PUSH-PULL TRANSISTORS

#### MAXIMUM RATINGS

Rating	Symbol	Value	Unit
Collector-Emitter Voltage	$V_{CEO}$	30	Vdc
Collector-Base Voltage	$V_{CBO}$	60	Vdc
Emitter-Base Voltage	$V_{EBO}$	4.0	Vdc
Collector Current — Continuous	$I_C$	16	Adc
Total Device Dissipation @ $T_C = 25^\circ\text{C}$ (1) Derate above $25^\circ\text{C}$	$P_D$	270 1.54	Watts W/ $^\circ\text{C}$
Storage Temperature Range	$T_{stg}$	-65 to +150	$^\circ\text{C}$
Junction Temperature	$T_J$	200	$^\circ\text{C}$

#### THERMAL CHARACTERISTICS

Characteristic	Symbol	Max	Unit
Thermal Resistance, Junction to Case	$R_{\theta JC}$	0.65	$^\circ\text{C/W}$

#### NOTE:

- This device is designed for RF operation. The total device dissipation rating applies only when the device is operated as an RF push-pull amplifier.

## The RF Line Controlled “Q” Broadband Power Transistor 100W, 30 to 500MHz, 28V

Rev. V1

### ELECTRICAL CHARACTERISTICS (T<sub>C</sub> = 25°C unless otherwise noted.)

Characteristic	Symbol	Min	Typ	Max	Unit
----------------	--------	-----	-----	-----	------

#### OFF CHARACTERISTICS (1)

Collector–Emitter Breakdown Voltage (I <sub>C</sub> = 50 mA <sub>dc</sub> , I <sub>B</sub> = 0)	V <sub>(BR)CEO</sub>	30	—	—	V <sub>dc</sub>
Collector–Emitter Breakdown Voltage (I <sub>C</sub> = 50 mA <sub>dc</sub> , V <sub>BE</sub> = 0)	V <sub>(BR)CES</sub>	60	—	—	V <sub>dc</sub>
Emitter–Base Breakdown Voltage (I <sub>E</sub> = 5.0 mA <sub>dc</sub> , I <sub>C</sub> = 0)	V <sub>(BR)EBO</sub>	4.0	—	—	V <sub>dc</sub>
Collector Cutoff Current (V <sub>CB</sub> = 30 V <sub>dc</sub> , I <sub>E</sub> = 0)	I <sub>CBO</sub>	—	—	5.0	mA <sub>dc</sub>

#### ON CHARACTERISTICS (1)

DC Current Gain (I <sub>C</sub> = 1.0 A <sub>dc</sub> , V <sub>CE</sub> = 5.0 V <sub>dc</sub> )	h <sub>FE</sub>	20	—	100	—
---	-----------------	----	---	-----	---

#### DYNAMIC CHARACTERISTICS (1)

Output Capacitance (V <sub>CB</sub> = 28 V <sub>dc</sub> , I <sub>E</sub> = 0, f = 1.0 MHz)	C <sub>ob</sub>	40	75	95	pF
---	-----------------	----	----	----	----

#### FUNCTIONAL TESTS (2) — See Figure 1

Common–Emitter Amplifier Power Gain (V <sub>CC</sub> = 28 V <sub>dc</sub> , P <sub>out</sub> = 100 W, f = 500 MHz)	G <sub>pe</sub>	7.5	8.5	—	dB
Collector Efficiency (V <sub>CC</sub> = 28 V <sub>dc</sub> , P <sub>out</sub> = 100 W, f = 500 MHz)	η	50	55	—	%
Load Mismatch (V <sub>CC</sub> = 28 V <sub>dc</sub> , P <sub>out</sub> = 100 W, f = 500 MHz, VSWR = 30:1, all phase angles)	ψ	No Degradation in Output Power			

#### NOTES:

- Each transistor chip measured separately.
- Both transistor chips operating in push–pull amplifier.

## The RF Line Controlled “Q” Broadband Power Transistor 100W, 30 to 500MHz, 28V

Rev. V1

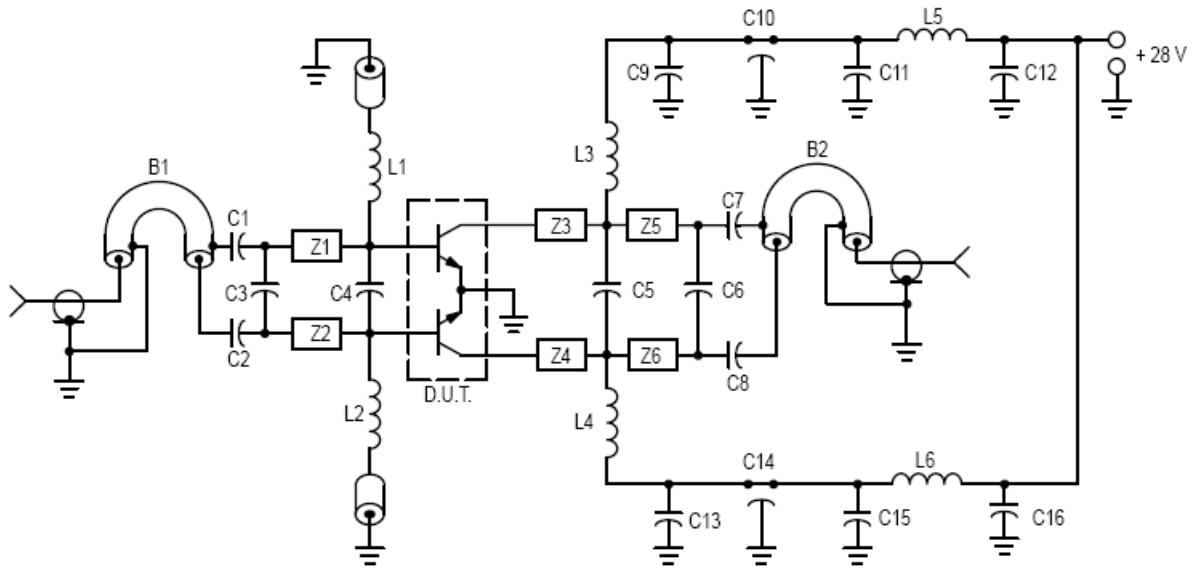

C1, C2, C7, C8 — 240 pF 100 mil Chip Cap  
 C3 — 15 pF 100 mil Chip Cap  
 C4 — 24 pF 100 mil Chip Cap  
 C5 — 33 pF 100 mil Chip Cap  
 C6 — 12 pF 100 mil Chip Cap  
 C9, C13 — 1000 pF 100 mil Chip Cap  
 C10, C14 — 680 pF Feedthru Cap  
 C11, C15 — 0.1  $\mu$ F Ceramic Disc Cap  
 C12, C16 — 50  $\mu$ F 50 V

L1, L2 — 0.15  $\mu$ H Molded Choke with Ferrite Bead  
 L3, L4 — 2-1/2 Turns #20 AWG 0.200" ID  
 L5, L6 — 3-1/2 Turns #18 AWG 0.200" ID  
 B1, B2 — Balun 50  $\Omega$  Semi Rigid Coax, 86 mil OD, 4" Long  
 Z1, Z2 — 850 mil Long x 125 mil W. Microstrip  
 Z3, Z4 — 200 mil Long x 125 mil W. Microstrip  
 Z5, Z6 — 800 mil Long x 125 mil W. Microstrip  
 Board Material — 0.0325" Teflon-Fiberglass,  $\epsilon_r = 2.56$ ,  
 1 oz. Copper Clad both sides.

Figure 1. 500 MHz Test Fixture

## The RF Line Controlled "Q" Broadband Power Transistor 100W, 30 to 500MHz, 28V

Rev. V1

### CLASS C

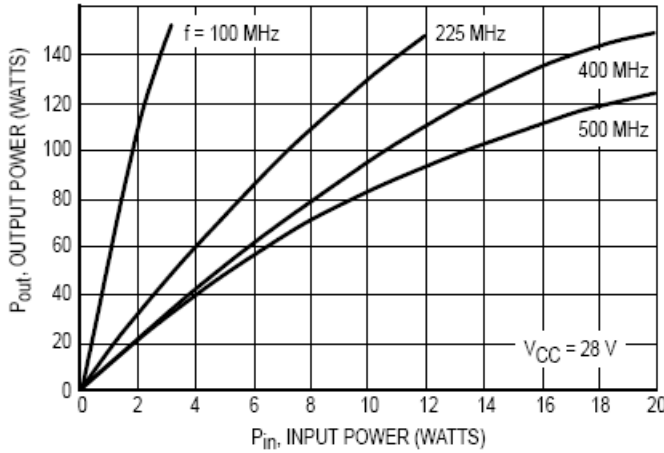

Figure 2. Output Power versus Input Power

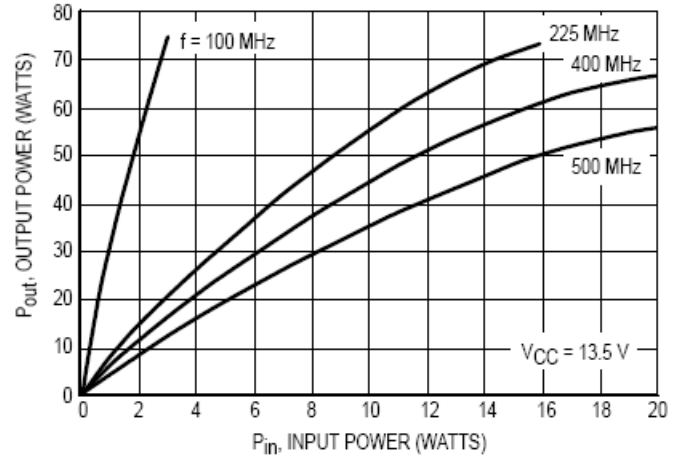

Figure 3. Output Power versus Input Power

### CLASS C

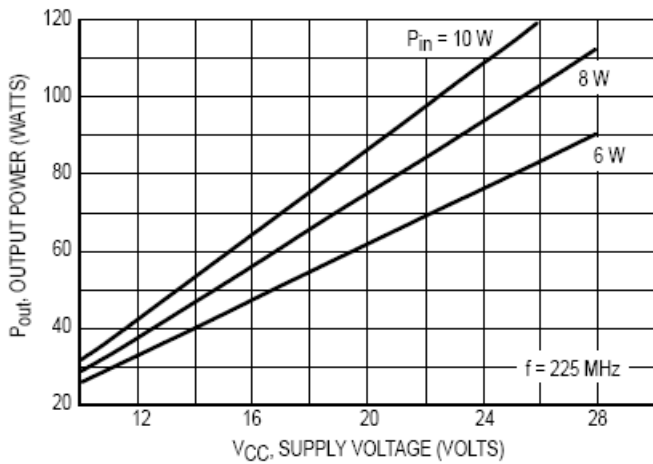

Figure 4. Output Power versus Supply Voltage

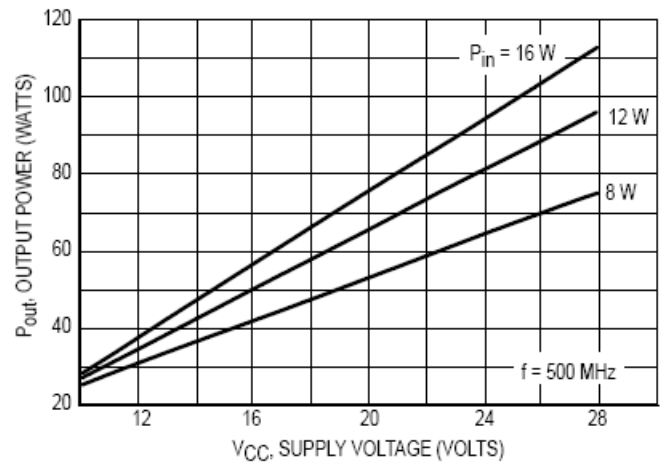

Figure 5. Output Power versus Supply Voltage

## The RF Line Controlled “Q” Broadband Power Transistor 100W, 30 to 500MHz, 28V

Rev. V1

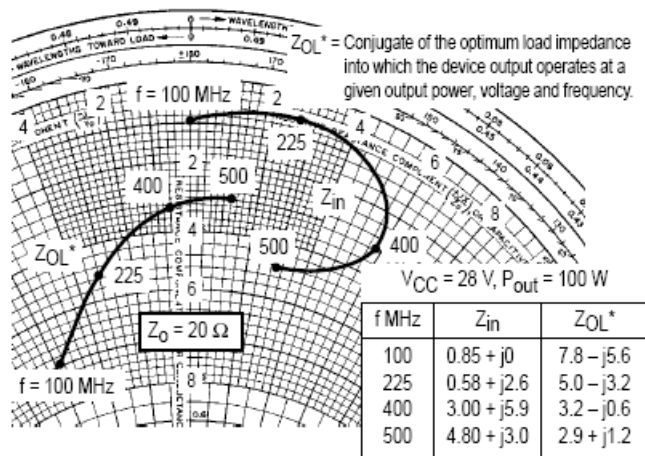

Figure 6. Series Equivalent Input/Output Impedance

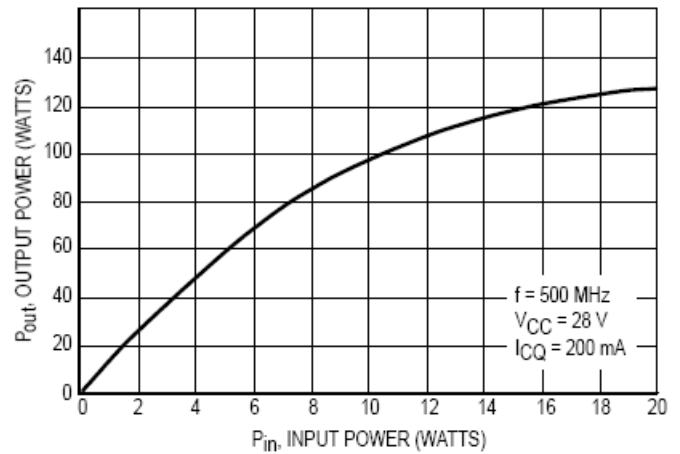
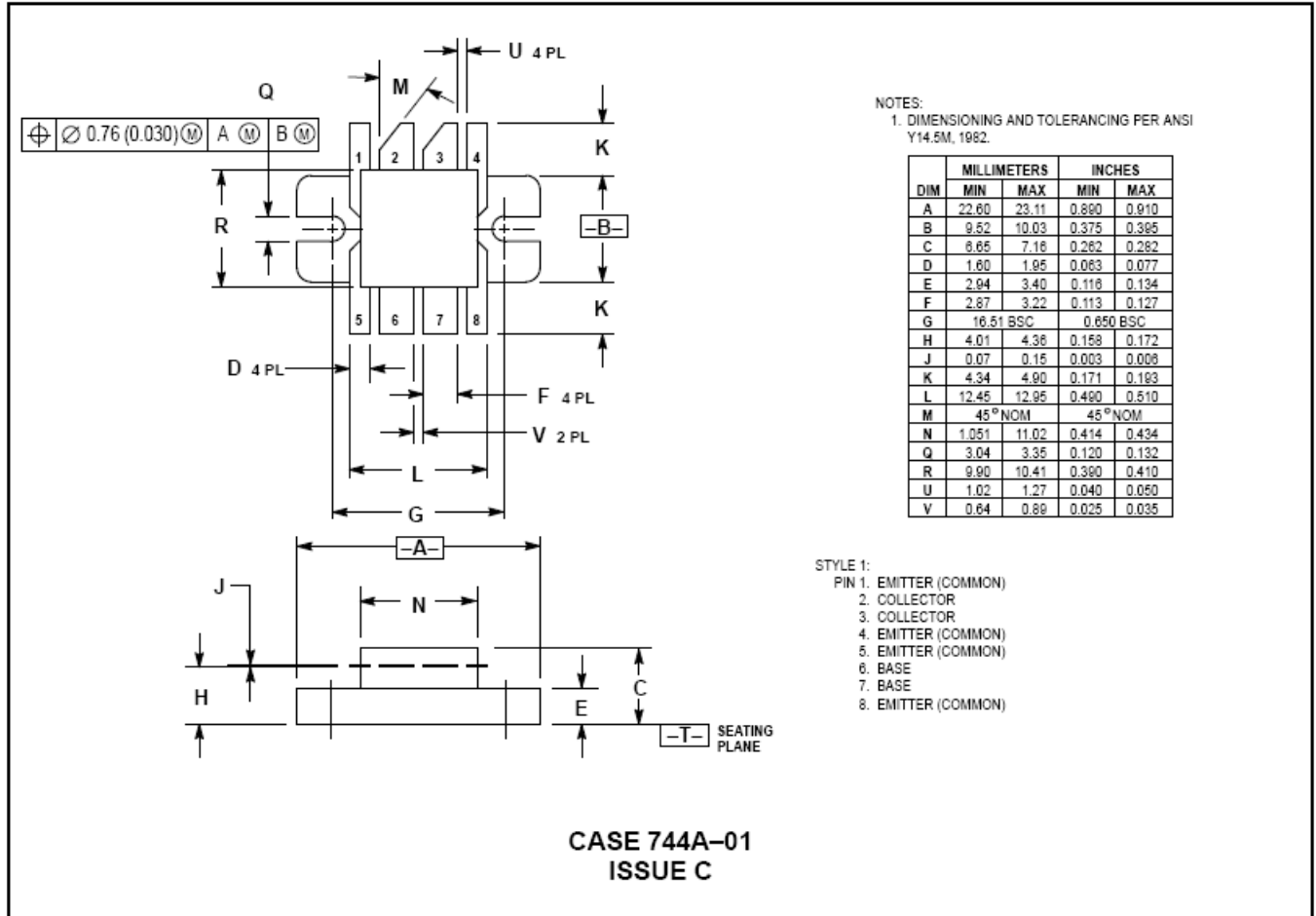

Figure 7. Class AB Output Power versus Input Power

The RF Line Controlled "Q" Broadband Power Transistor  
100W, 30 to 500MHz, 28V

Rev. V1

## PACKAGE DIMENSIONS



M/A-COM Technology Solutions Inc. All rights reserved.

Information in this document is provided in connection with M/A-COM Technology Solutions Inc ("MACOM") products. These materials are provided by MACOM as a service to its customers and may be used for informational purposes only. Except as provided in MACOM's Terms and Conditions of Sale for such products or in any separate agreement related to this document, MACOM assumes no liability whatsoever. MACOM assumes no responsibility for errors or omissions in these materials. MACOM may make changes to specifications and product descriptions at any time, without notice. MACOM makes no commitment to update the information and shall have no responsibility whatsoever for conflicts or incompatibilities arising from future changes to its specifications and product descriptions. No license, express or implied, by estoppel or otherwise, to any intellectual property rights is granted by this document.

THESE MATERIALS ARE PROVIDED "AS IS" WITHOUT WARRANTY OF ANY KIND, EITHER EXPRESS OR IMPLIED, RELATING TO SALE AND/OR USE OF MACOM PRODUCTS INCLUDING LIABILITY OR WARRANTIES RELATING TO FITNESS FOR A PARTICULAR PURPOSE, CONSEQUENTIAL OR INCIDENTAL DAMAGES, MERCHANTABILITY, OR INFRINGEMENT OF ANY PATENT, COPYRIGHT OR OTHER INTELLECTUAL PROPERTY RIGHT. MACOM FURTHER DOES NOT WARRANT THE ACCURACY OR COMPLETENESS OF THE INFORMATION, TEXT, GRAPHICS OR OTHER ITEMS CONTAINED WITHIN THESE MATERIALS. MACOM SHALL NOT BE LIABLE FOR ANY SPECIAL, INDIRECT, INCIDENTAL, OR CONSEQUENTIAL DAMAGES, INCLUDING WITHOUT LIMITATION, LOST REVENUES OR LOST PROFITS, WHICH MAY RESULT FROM THE USE OF THESE MATERIALS.

MACOM products are not intended for use in medical, lifesaving or life sustaining applications. MACOM customers using or selling MACOM products for use in such applications do so at their own risk and agree to fully indemnify MACOM for any damages resulting from such improper use or sale.

## X-ON Electronics

Largest Supplier of Electrical and Electronic Components

*Click to view similar products for [RF Bipolar Transistors](#) category:*

*Click to view products by [MACOM](#) manufacturer:*

Other Similar products are found below :

[MAPRST0912-50](#) [MCH4016-TL-H](#) [MMBT5551-G](#) [MRF10120](#) [15GN01CA-TB-E](#) [PH1214-25M](#) [MAPRST0912-350](#) [MMBTH10-TP](#) [BFP640F H6327](#) [BFR 360F H6765](#) [MRF10031](#) [NSVF4009SG4T1G](#) [BFP 182R E7764](#) [BFP405H6740XTSA1](#) [MRF10350](#) [ASMA201](#) [BFR360FH6765XTSA1](#) [BFP410H6327XTSA1](#) [BFP620FH7764XTSA1](#) [BFP720ESDH6327XTSA1](#) [BFP720FH6327XTSA1](#) [BFR360L3E6765XTMA1](#) [BFP420H6433XTMA1](#) [BFP420H6740XTSA1](#) [BFP420H6801XTSA1](#) [MCH4015-TL-H](#) [BF888H6327XTSA1](#) [MMBT2222A-G](#) [BFP196WH6327XTSA1](#) [BFP405FH6327XTSA1](#) [BFP640ESDH6327XTSA1](#) [BFR193L3E6327XTMA1](#) [BFS483H6327XTSA1](#) [NSVF4020SG4T1G](#) [NSVF6003SB6T1G](#) [MRF10005](#) [BFP420FH6327XTSA1](#) [BFP740FESDH6327XTSA1](#) [BFR181E6327HTSA1](#) [BFR181WH6327XTSA1](#) [BFR182E6327HTSA1](#) [BFR193E6327HTSA1](#) [BFP181E7764HTSA1](#) [BFP183WH6327XTSA1](#) [BFP720H6327XTSA1](#) [BFR182WH6327XTSA1](#) [BFU590GX](#) [MAPR-000912-500S00](#) [BFR340FH6327XTSA1](#) [STGWT30HP65FB](#)