

Features

- Very Low 1/f Noise
- Detector Applications up to 40 GHz
- Chip Beam Lead and Packaged Devices

Description

The MSS39-xxx-x Series of Schottky diodes is fabricated on P-Type epitaxial substrates for superior 1/f noise performance in microwave biased-detector applications up to 40 GHz.



Chip

Electrical Specifications: $T_A = 25^\circ\text{C}$

Model	V_{BR} Min. V	V_F Typ. V	C_J Max. pF	T_{SS} Ttp. dBm	γ Typ. mV / mW	Frequency Max. GHz	Outline
MSS39-045-C15	5	0.40	0.10	-58	5,000	18	C15
MSS39-048-C15	5	0.39	0.15	-58	5,000	12	C15
Test Conditions	$I_R = 10 \mu\text{A}$	$I_F = 1 \text{ mA}$	$V_R = 0 \text{ V},$ $F = 1 \text{ MHz}$	DC Bias = 10 mA, F = 10 GHz $R_L = 100 \text{ K}\Omega$ Video BW = 2 MHz			

Beam Lead

Electrical Specifications: $T_A = 25^\circ\text{C}$

Model	V_{BR} Min. V	V_F Typ. V	C_J Max. pF	T_{SS} Ttp. dBm	γ Typ. mV / mW	Frequency Max. GHz	Outline
MSS39-144-B10B	3.5	0.38	0.08	-58	5,000	40	B10B
MSS39-146-B10B	3.5	0.38	0.10	-58	5,000	26	B10B
MSS39-148-B10B	3.5	0.39	0.12	-58	5,000	18	B10B
MSS39-152-B10B	3.5	0.38	0.18	-58	5,000	12	B10B
Test Conditions	$I_R = 10 \mu\text{A}$	$I_F = 1 \text{ mA}$	$V_R = 0 \text{ V},$ $F = 1 \text{ MHz}$	DC Bias = 10 mA, F = 10 GHz $R_L = 100 \text{ K}\Omega$ Video BW = 2 MHz			

(Continued next page)

Packaged

Electrical Specifications: $T_A = 25^\circ\text{C}$

Model	V_{BR} Min. V	V_F Typ. V	C_J Max. pF	T_{SS} Ttp. dBm	γ Typ. mV / mW	Frequency Max. GHz	Outline
MSS39-045-P55	5.0	0.40	0.25	-58	5000	18	P55
MSS39-045-P86	5.0	0.40	0.27	-58	5000	18	P86
MSS39-048-P55	5.0	0.39	0.30	-58	5000	12	P55
MSS39-048-P86	5.0	0.39	0.32	-58	5000	12	P86
MSS39-148-E25	3.5	0.39	0.22	-58	5000	18	E25
MSS39-148-H20	3.5	0.39	0.30	-58	5000	12	H20
MSS39-152-E25	3.5	0.38	0.28	-58	5000	12	E25
MSS39-152-H20	3.5	0.38	0.36	-58	5000	18	H20
Test Conditions	$I_R = 10 \mu\text{A}$	$I_F = 1 \text{ mA}$	$V_R = 0 \text{ V},$ $F = 1 \text{ MHz}$	DC Bias = 10 mA, F = 10 GHz $R_L = 100 \text{ K}\Omega$ Video BW = 2 MHz			

Absolute Maximum Ratings

Parameters	Rating
Reverse Voltage	1 V
Forward Current	50 mA
CW Power Dissipation	100 mW, derated linearly to 0 @ $T_A = +150^\circ\text{C}$
Operating Temperature	-65°C to $+150^\circ\text{C}$
Storage Temperature	-65°C to $+150^\circ\text{C}$
Soldering Temperature (packaged)	$+230^\circ\text{C}$ for 5 seconds

Typical Performance Curves: $T_A = 25^\circ\text{C}$

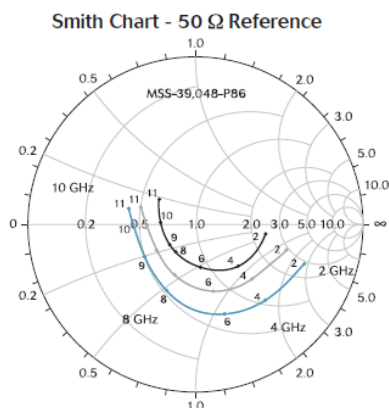
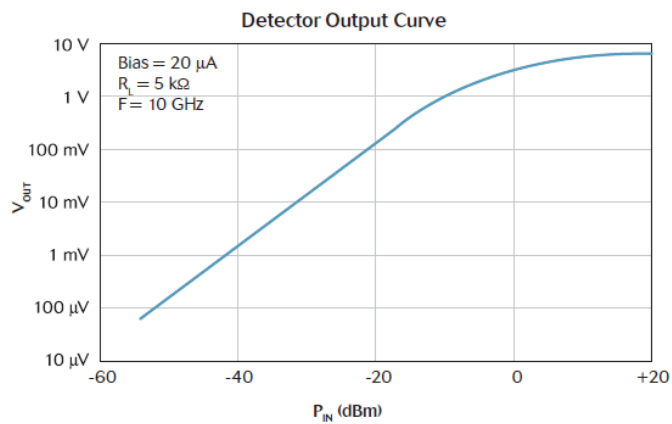
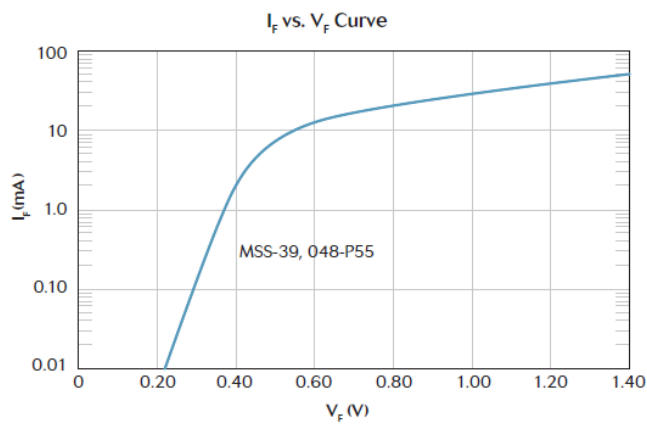

MSS39-xxx-x Series



P-Type Silicon Schottky Diodes

Rev. V1

Outline Drawings

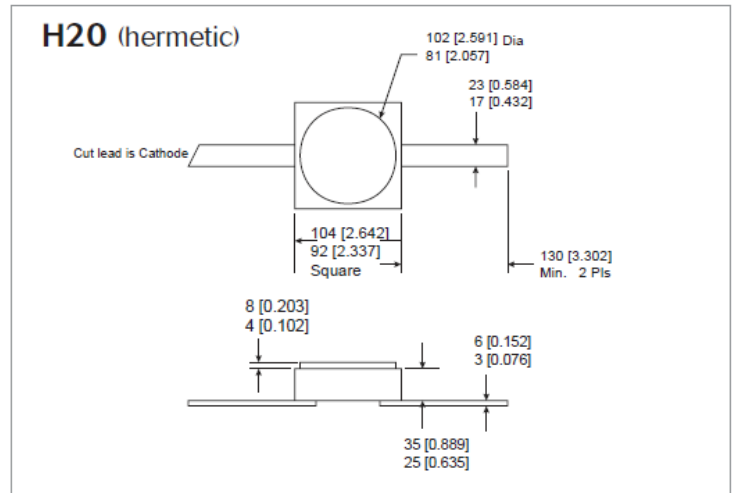
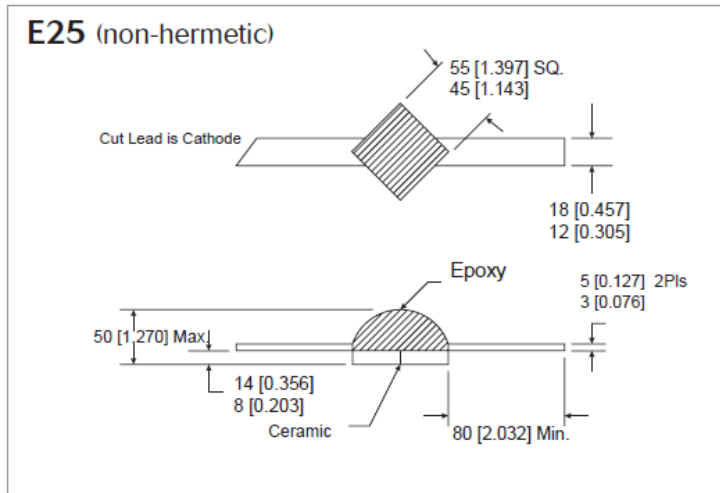
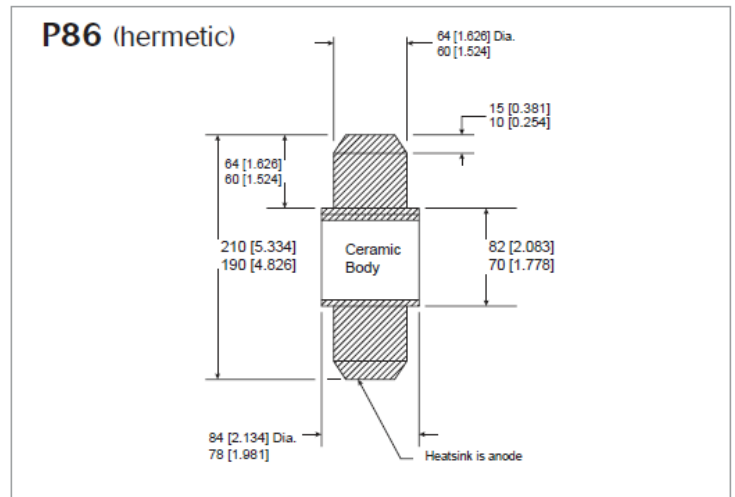
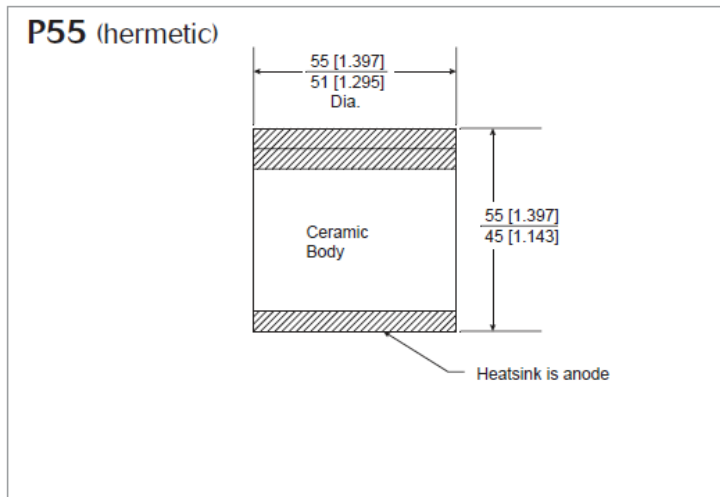
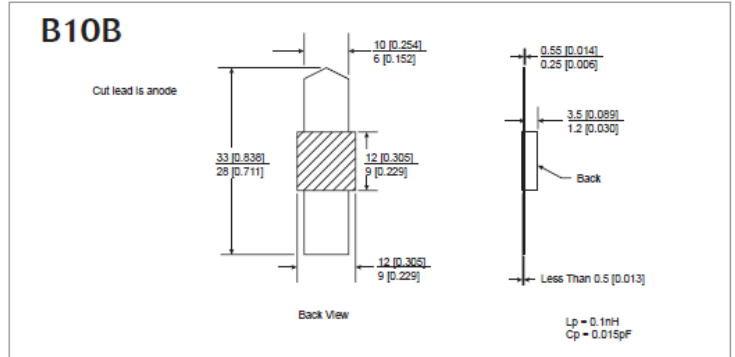
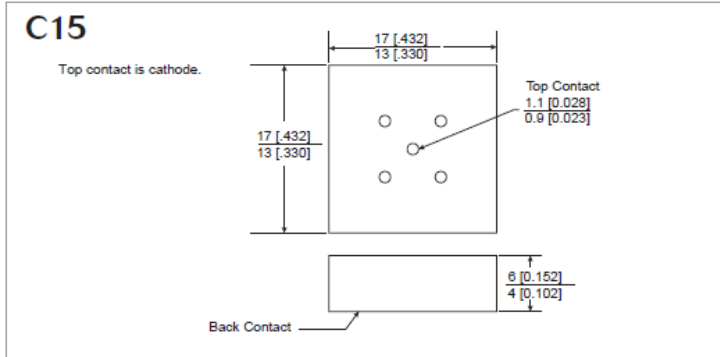

MACOM Technology Solutions Inc. All rights reserved.

Information in this document is provided in connection with MACOM Technology Solutions Inc ("MACOM") products. These materials are provided by MACOM as a service to its customers and may be used for informational purposes only. Except as provided in MACOM's Terms and Conditions of Sale for such products or in any separate agreement related to this document, MACOM assumes no liability whatsoever. MACOM assumes no responsibility for errors or omissions in these materials. MACOM may make changes to specifications and product descriptions at any time, without notice. MACOM makes no commitment to update the information and shall have no responsibility whatsoever for conflicts or incompatibilities arising from future changes to its specifications and product descriptions. No license, express or implied, by estoppel or otherwise, to any intellectual property rights is granted by this document.

THESE MATERIALS ARE PROVIDED "AS IS" WITHOUT WARRANTY OF ANY KIND, EITHER EXPRESS OR IMPLIED, RELATING TO SALE AND/OR USE OF MACOM PRODUCTS INCLUDING LIABILITY OR WARRANTIES RELATING TO FITNESS FOR A PARTICULAR PURPOSE, CONSEQUENTIAL OR INCIDENTAL DAMAGES, MERCHANTABILITY, OR INFRINGEMENT OF ANY PATENT, COPYRIGHT OR OTHER INTELLECTUAL PROPERTY RIGHT. MACOM FURTHER DOES NOT WARRANT THE ACCURACY OR COMPLETENESS OF THE INFORMATION, TEXT, GRAPHICS OR OTHER ITEMS CONTAINED WITHIN THESE MATERIALS. MACOM SHALL NOT BE LIABLE FOR ANY SPECIAL, INDIRECT, INCIDENTAL, OR CONSEQUENTIAL DAMAGES, INCLUDING WITHOUT LIMITATION, LOST REVENUES OR LOST PROFITS, WHICH MAY RESULT FROM THE USE OF THESE MATERIALS.

MACOM products are not intended for use in medical, lifesaving or life sustaining applications. MACOM customers using or selling MACOM products for use in such applications do so at their own risk and agree to fully indemnify MACOM for any damages resulting from such improper use or sale.

X-ON Electronics

Largest Supplier of Electrical and Electronic Components

Click to view similar products for [Schottky Diodes & Rectifiers](#) category:

Click to view products by [MACOM](#) manufacturer:

Other Similar products are found below :

[MA4E2039](#) [D1FH3-5063](#) [MBR10100CT-BP](#) [MBR1545CT](#) [MMBD301M3T5G](#) [RB160M-50TR](#) [RB551V-30](#) [BAS16E6433HTMA1](#) [BAT](#)
[54-02LRH E6327](#) [NSR05F40QNXT5G](#) [NTE555](#) [JANS1N6640](#) [SB07-03C-TB-H](#) [SB1003M3-TL-W](#) [SK310-T](#) [SK32A-LTP](#) [SK34B-TP](#)
[SS3003CH-TL-E](#) [GA01SHT18](#) [CRS10I30A\(TE85L,QM](#) [MA4E2501L-1290](#) [MBRB30H30CT-1G](#) [SB007-03C-TB-E](#) [SK32A-TP](#) [SK33B-TP](#)
[SK38B-TP](#) [NRVBM120LT1G](#) [NTE505](#) [NTSB30U100CT-1G](#) [SS15E-TP](#) [VS-6CWQ10FNHM3](#) [ACDBA1100LR-HF](#) [ACDBA1200-HF](#)
[ACDBA140-HF](#) [ACDBA2100-HF](#) [ACDBA3100-HF](#) [CDBQC0530L-HF](#) [CDBQC0240LR-HF](#) [ACDBA260LR-HF](#) [ACDBA1100-HF](#)
[SK310B-TP](#) [MA4E2502L-1246](#) [MA4E2502H-1246](#) [NRVBM120ET1G](#) [NSR01L30MXT5G](#) [NTE573](#) [NTE6081](#) [SB560](#) [PMAD1108-LF](#)
[SD103ATW-TP](#)