

# GaN Amplifier 28 V, 5 W 20 - 2700 MHz



**NPA1008**

Rev. V5

## Features

- GaN on Si HEMT D-Mode Integrated Amplifier
- Suitable for Linear & Saturated Applications
- Broadband Operation from 20 - 2700 MHz
- 50  $\Omega$  Input Matched
- 28 V Operation
- 45% Drain Efficiency
- 100% RF Tested
- Lead-Free 4 mm 24-lead PQFN Package
- Halogen-Free “Green” Mold Compound
- RoHS\* Compliant



## Description

The NPA1008 is an integrated GaN on silicon power amplifier optimized for 20 - 2700 MHz operation. This amplifier has been designed for saturated and linear operation with output levels to 5 W (37 dBm) assembled in a lead-free 4 x 4 mm 24-lead QFN plastic package.

The NPA1008 is ideally suited for general purpose narrowband to broadband applications in test and measurement, defense communications, land mobile radio and wireless infrastructure.

## Functional Schematic

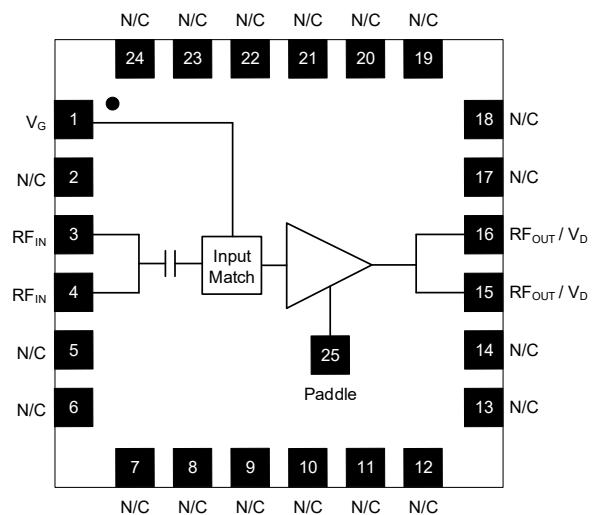

## Pin Designations

Pin #	Pin Name	Function
1	V <sub>G</sub>	Gate - DC Bias
2	N/C <sup>1</sup>	No Connection
3,4	RF <sub>IN</sub>	RF Input
5-14	N/C <sup>1</sup>	No Connection
15,16	RF <sub>OUT</sub> / V <sub>D</sub>	RF Output / Drain
17-24	N/C <sup>1</sup>	No Connection
25	Paddle <sup>2</sup>	Ground / Source

1. All no connection pins may be left floating or grounded.
2. The exposed pad centered on the package bottom must be connected to RF and DC ground. This path must also provide a low thermal resistance heat path.

## Ordering Information

Part Number	Package
NPA1008	Bulk Quantity
NPA1008-SMB	Sample Board

\* Restrictions on Hazardous Substances, compliant to current RoHS EU directive.

# GaN Amplifier 28 V, 5 W 20 - 2700 MHz



**NPA1008**

Rev. V5

## RF Electrical Specifications: $T_C = 25^\circ\text{C}$ , $V_{DS} = 28\text{ V}$ , $I_{DQ} = 88\text{ mA}$

Parameter	Test Conditions	Symbol	Min.	Typ.	Max.	Units
Small Signal Gain	CW, 1900 MHz	$G_{SS}$	-	15.6	-	dB
Gain	CW, $P_{OUT} = 37\text{ dBm}$ , 1900 MHz	$G_P$	10.5	12.0	-	dB
Saturated Output Power	CW, 1900 MHz	$P_{SAT}$	-	38.9	-	dBm
Drain Efficiency	CW, 1900 MHz	$\eta_{SAT}$	44	47.0	-	%
Power Added Efficiency	CW, $P_{OUT} = 37\text{ dBm}$ , 1900 MHz	PAE	-	44.7	-	%
Ruggedness	All phase angles	$\Psi$	VSWR = 15:1, No Device Damage			

## DC Electrical Specifications: $T_C = 25^\circ\text{C}$

Parameter	Test Conditions	Symbol	Min.	Typ.	Max.	Units
Drain-Source Leakage Current	$V_{GS} = -8\text{ V}$ , $V_{DS} = 100\text{ V}$	$I_{DLK}$	-	4	-	mA
Gate-Source Leakage Current	$V_{GS} = -8\text{ V}$ , $V_{DS} = 0\text{ V}$	$I_{GLK}$	-	2	-	mA
Gate Threshold Voltage	$V_{DS} = 28\text{ V}$ , $I_D = 4\text{ mA}$	$V_T$	-2.5	-1.5	-0.5	V
Gate Quiescent Voltage	$V_{DS} = 28\text{ V}$ , $I_D = 88\text{ mA}$	$V_{GSQ}$	-2.1	-1.2	-0.3	V
On Resistance	$V_{DS} = 2\text{ V}$ , $I_D = 45\text{ mA}$	$R_{ON}$	-	1.2	-	$\Omega$
Saturated Drain Current	$V_{DS} = 7\text{ V}$ pulsed, pulse width 300 $\mu\text{s}$	$I_{D(SAT)}$	-	2.3	-	A

# GaN Amplifier 28 V, 5 W 20 - 2700 MHz



NPA1008

Rev. V5

## Absolute Maximum Ratings<sup>3,4,5</sup>

Parameter	Absolute Maximum
Drain Source Voltage, $V_{DS}$	100 V
Gate Source Voltage, $V_{GS}$	-10 to 3 V
Gate Current, $I_G$	12 mA
Junction Temperature, $T_J$	+200°C
Operating Temperature	-40°C to +85°C
Storage Temperature	-65°C to +150°C
ESD Min. - Human Body Model (HBM)	+350 V

- Exceeding any one or combination of these limits may cause permanent damage to this device.
- MACOM does not recommend sustained operation near these survivability limits.
- Operating at nominal conditions with  $T_J \leq 200^\circ\text{C}$  will ensure  $\text{MTTF} > 1 \times 10^6$  hours.

## Thermal Characteristics<sup>6,7</sup>

Parameter	Test Conditions	Symbol	Typical	Units
Thermal Resistance	$V_{DS} = 28 \text{ V}, T_J = 200^\circ\text{C}$	$\Theta_{JC}$	12.1	°C/W

- Junction temperature ( $T_J$ ) measured using IR Microscopy. Case temperature measured using thermocouple embedded in heat-sink.
- The thermal resistance of the mounting configuration must be added to the device  $\Theta_{JC}$ , for proper  $T_J$  calculation during operation. The recommended via pattern, shown on page 4, on a 20 mil thick, 1 oz plated copper, PCB adds an additional 4 °C/W to the typical value.

## Handling Procedures

Please observe the following precautions to avoid damage:

## Static Sensitivity

Gallium Nitride Circuits are sensitive to electrostatic discharge (ESD) and can be damaged by static electricity. Proper ESD control techniques should be used when handling these HBM Class 1B devices.

# GaN Amplifier 28 V, 5 W 20 - 2700 MHz



**NPA1008**  
Rev. V5

## Evaluation Board and Recommended Tuning Solution 20 - 2700 MHz Broadband Circuit

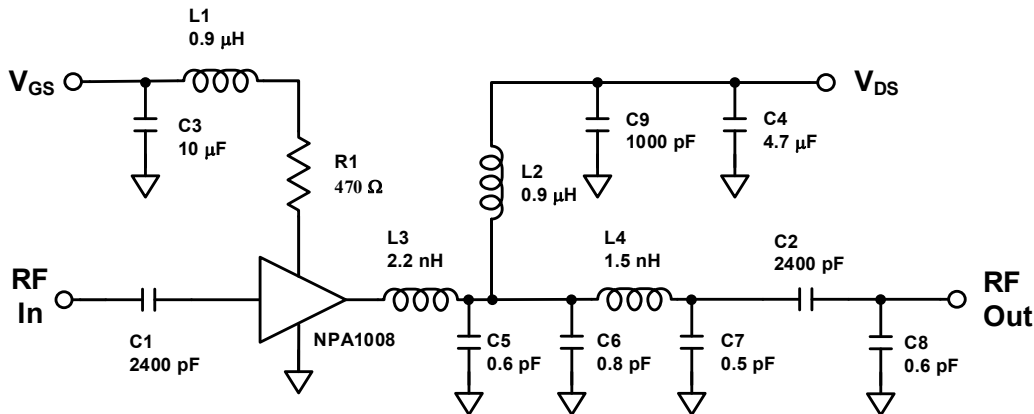

### Description

Parts measured on evaluation board (20-mil thick RO4350). The PCB's electrical and thermal ground is provided using a standard-plated densely packed via hole array (see recommended via pattern).

Matching is provided using a combination of lumped elements and transmission lines as shown in the simplified schematic above. Recommended tuning solution component placement, transmission lines, and details are shown on the next page.

### Bias Sequencing

#### Turning the device ON

1. Set  $V_{GS}$  to the pinch-off ( $V_P$ ), typically -5 V.
2. Turn on  $V_{DS}$  to nominal voltage (28 V).
3. Increase  $V_{GS}$  until the  $I_{DS}$  current is reached.
4. Apply RF power to desired level.

#### Turning the device OFF

1. Turn the RF power off.
2. Decrease  $V_{GS}$  down to  $V_P$ .
3. Decrease  $V_{DS}$  down to 0 V.
4. Turn off  $V_{GS}$ .

### Recommended Via Pattern (All dimensions shown as inches)

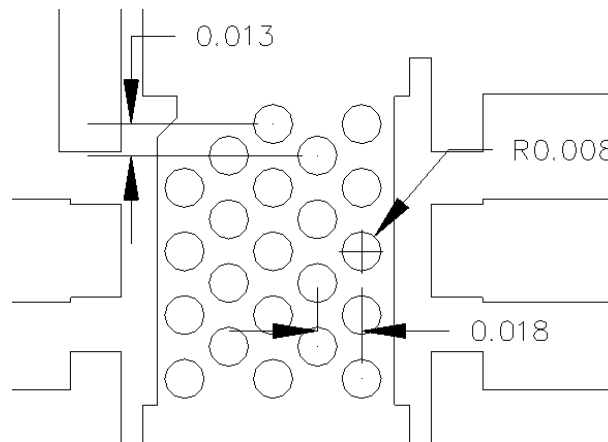

# GaN Amplifier 28 V, 5 W 20 - 2700 MHz



NPA1008

Rev. V5

## Evaluation Board and Recommended Tuning Solution

### 20 - 2700 MHz Broadband Circuit

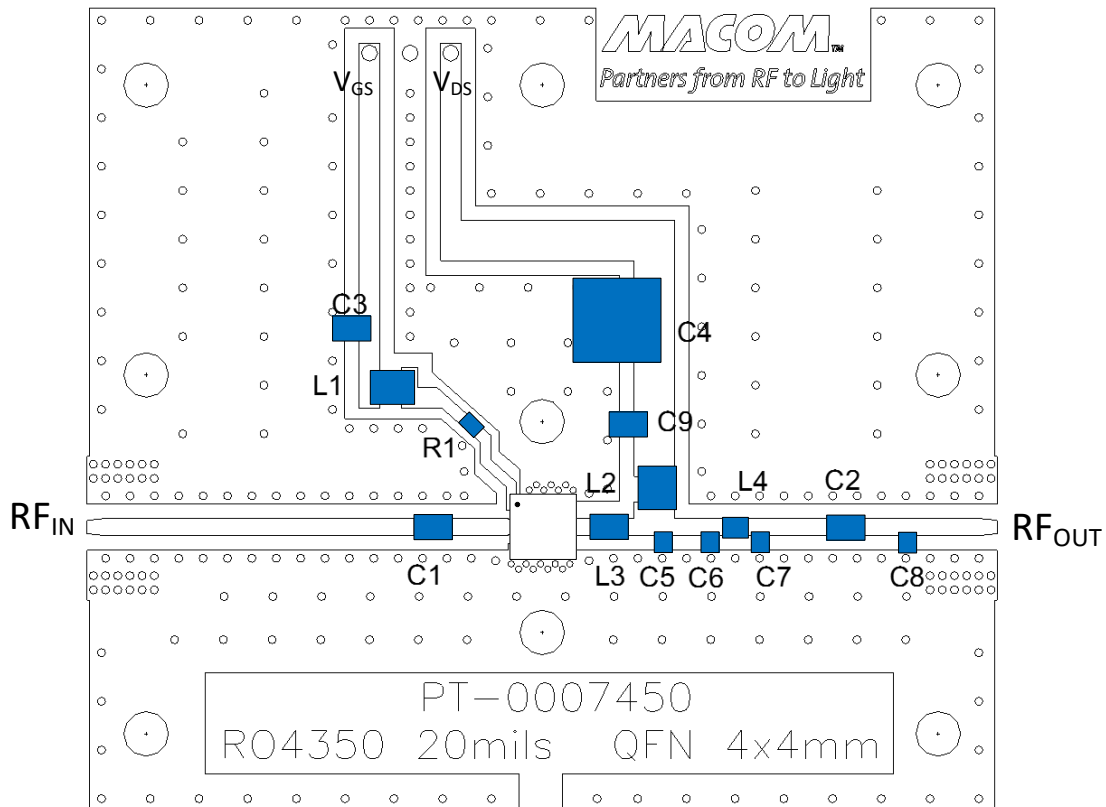

### Parts list

Reference	Value	Tolerance	Manufacturer	Part Number
C1, C2	2400 pF	-	Dielectric Labs, Inc.	C08BL242X-5UN-X0
C3	10 $\mu$ F	10%	TDK	C2012XR1C106M085AC
C4	4.7 $\mu$ F	10%	TDK	C5750X7R2A475K230KA
C5, C8	0.6 pF	0.1 pF	ATC	800A0R6BT250X
C6	0.8 pF	0.1 pF	ATC	800A0R8BT250X
C7	0.5 pF	0.1 pF	ATC	800A0R5BT250X
C9	1000 pF	10%	Kemet	C0805C102K1RACTU
R1	470 $\Omega$	10%	Panasonic	ERJ-P03F4700V
L1, L2	0.9 $\mu$ H	10%	Coilcraft	1008AF-901XJLC
L3	2.2 nH	$\pm 0.2$ nH	AVX	L08052R2CEW
L4	1.5 nH	$\pm 0.2$ nH	AVX	L06031R5CGS
PCB	Rogers RO4350, $\epsilon_r=3.5$ , 0.020"			

# GaN Amplifier 28 V, 5 W 20 - 2700 MHz



NPA1008

Rev. V5

Typical Performance as measured in the Broadband Evaluation Board:  
CW,  $V_{DS} = 28\text{ V}$ ,  $I_{DQ} = 88\text{ mA}$ ,  $T_C = 25^\circ\text{C}$  (unless noted)

Device s-parameters (Deembedded)

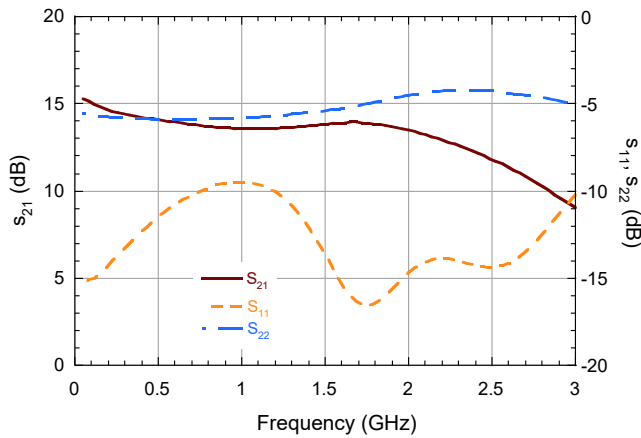

Broadband Circuit s-Parameters

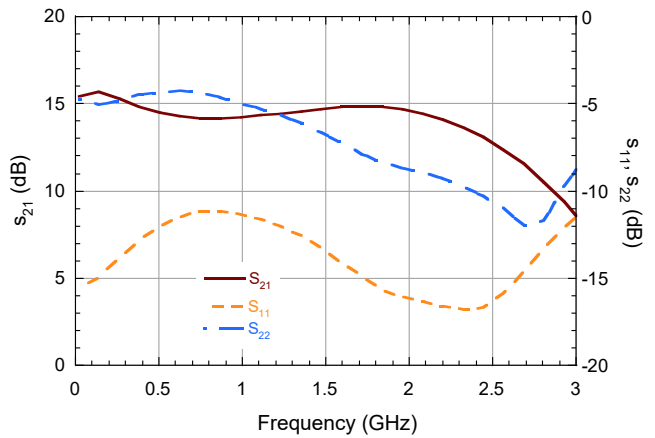

Performance vs. Frequency at  $P_{OUT} = 37\text{ dBm}$

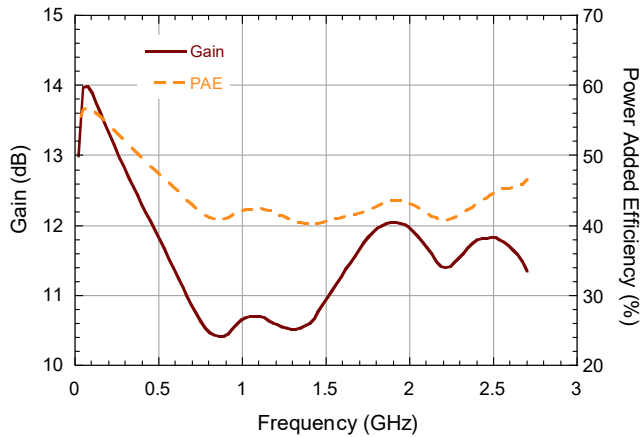

Performance vs. Input Return Loss at  $P_{OUT} = 37\text{ dBm}$

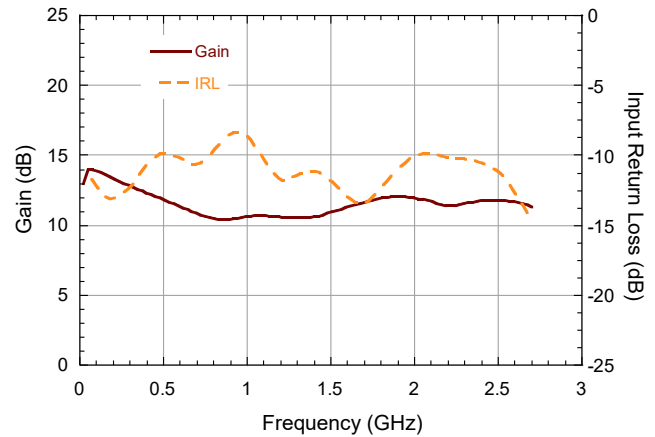

# GaN Amplifier 28 V, 5 W 20 - 2700 MHz



NPA1008

Rev. V5

**Typical Performance as measured in the Broadband Evaluation Board:  
CW,  $V_{DS} = 28$  V,  $I_{DQ} = 88$  mA,  $T_C = 25^\circ\text{C}$  (unless noted)**

**Gain vs. Frequency**

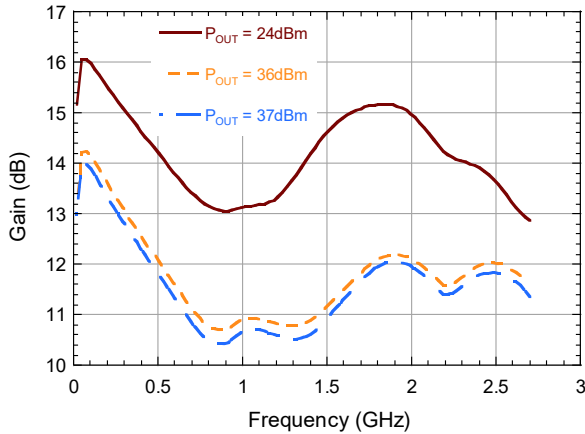

**Gain vs. Frequency at  $P_{OUT} = 37$  dBm**

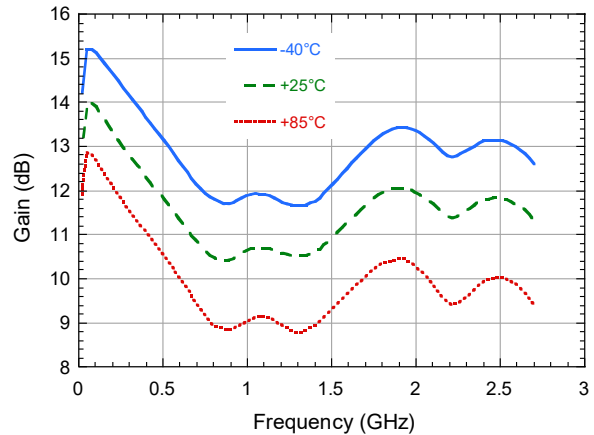

**Input Return Loss vs. Frequency**

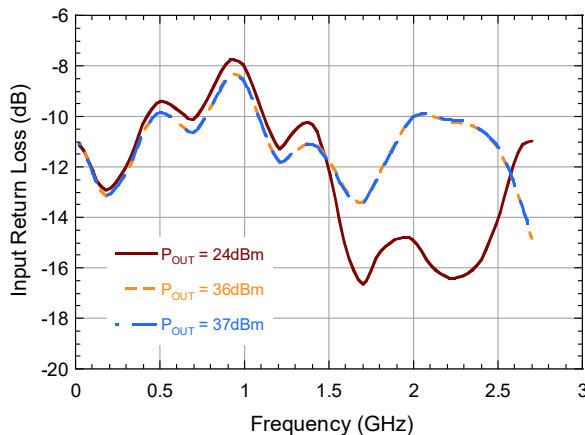

**Input Return Loss at  $P_{OUT} = 37$  dBm vs. Frequency**

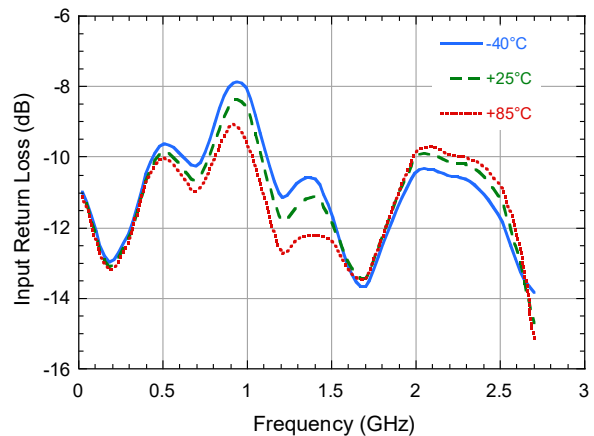

**Power Added Efficiency vs. Frequency**

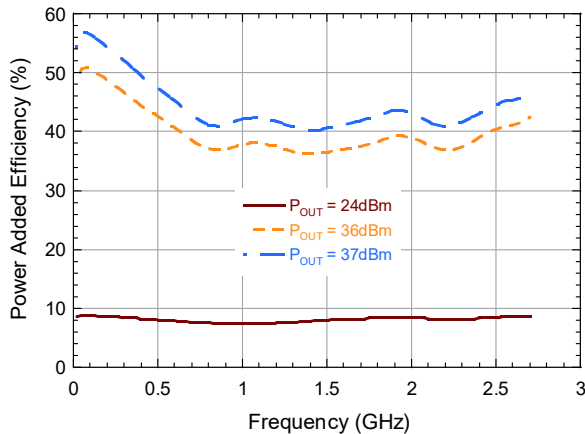

**Power Added Efficiency at  $P_{OUT} = 37$  dBm vs. Frequency**

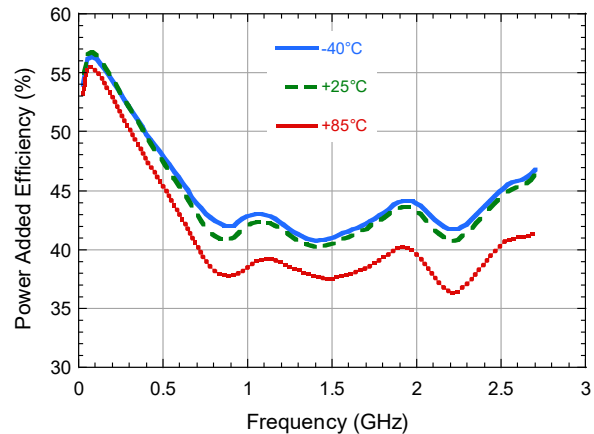

# GaN Amplifier 28 V, 5 W 20 - 2700 MHz



NPA1008

Rev. V5

**Typical Performance as measured in the Broadband Evaluation Board:  
CW,  $V_{DS} = 28\text{ V}$ ,  $I_{DQ} = 88\text{ mA}$ ,  $T_C = 25^\circ\text{C}$  (unless noted)**

**Gain vs.  $P_{OUT}$**

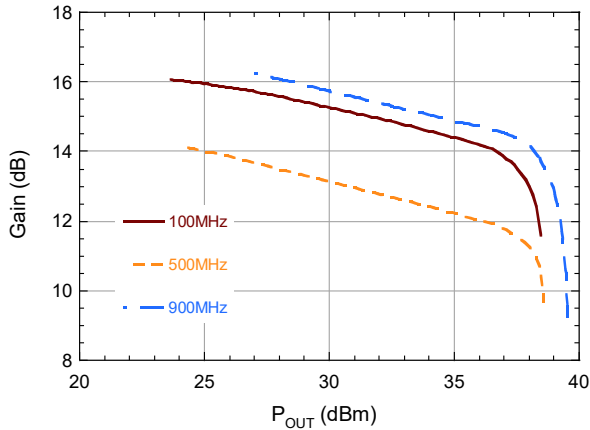

**Gain vs.  $P_{OUT}$**

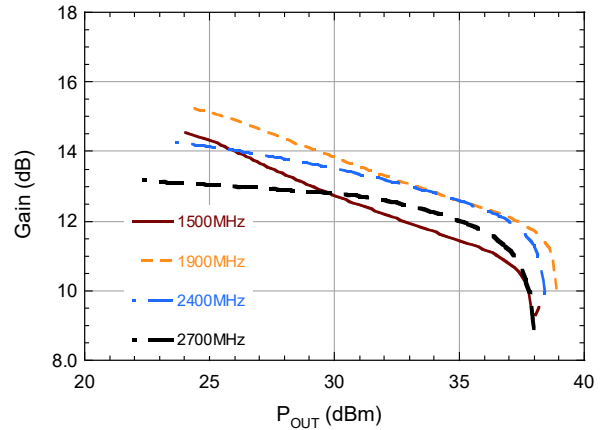

**Input Return Loss vs.  $P_{OUT}$**

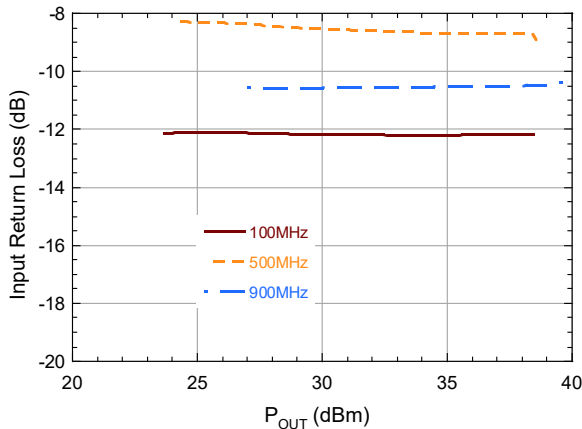

**Input Return Loss vs.  $P_{OUT}$**

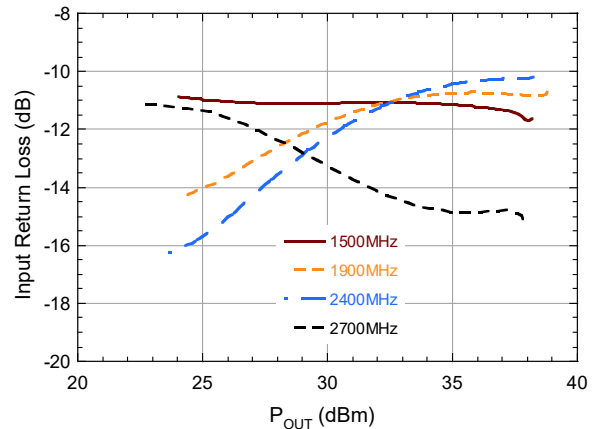

**Power Added Efficiency vs.  $P_{OUT}$**

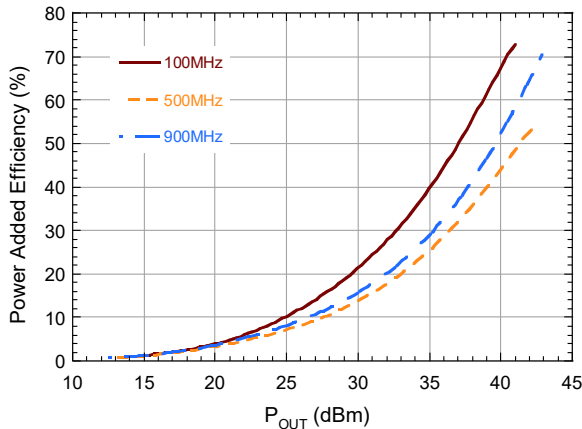

**Power Added Efficiency vs.  $P_{OUT}$**

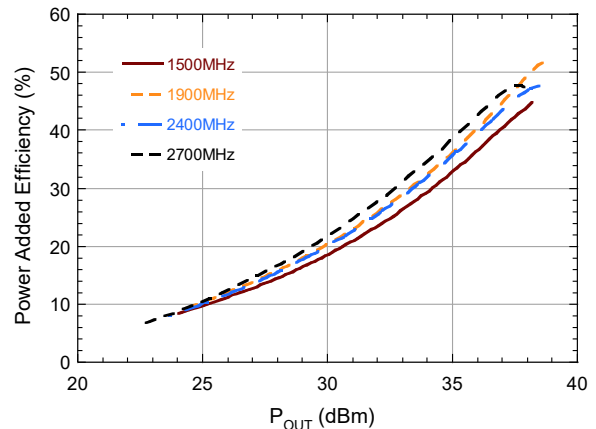



# GaN Amplifier 28 V, 5 W 20 - 2700 MHz



NPA1008

Rev. V5

**Typical 2-Tone Performance as measured in the Broadband Evaluation Board  
1 MHz Tone Spacing, Freq = 1900 MHz,  $V_{DS} = 28$  V,  $I_{DQ} = 88$  mA,  $T_C = 25^\circ\text{C}$  (unless noted)**

**2-Tone IMD vs. Output Power vs.  $I_{DQ}$**

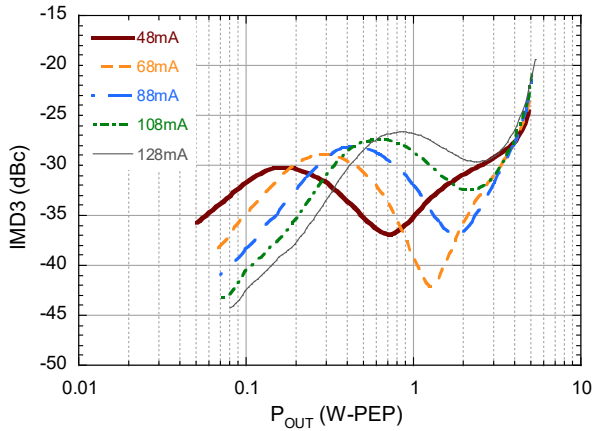

**2-Tone Gain vs. Output Power vs.  $I_{DQ}$**

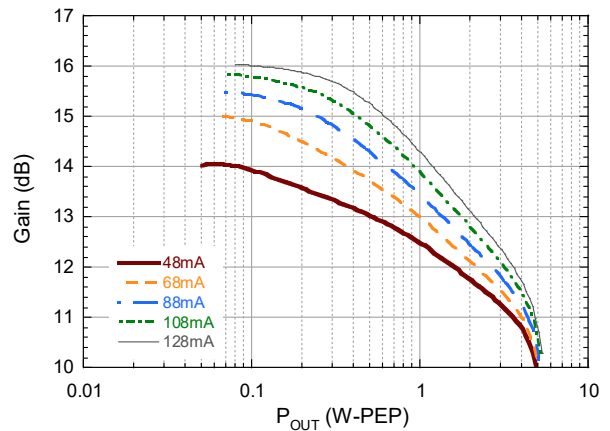

**2-Tone IMD vs. Output Power**

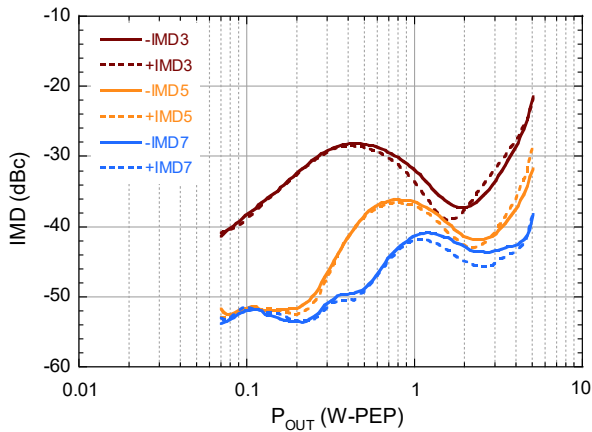

**2-Tone IMD vs. Tone Spacing ( $P_{OUT} = 37$  dBm-PEP)**

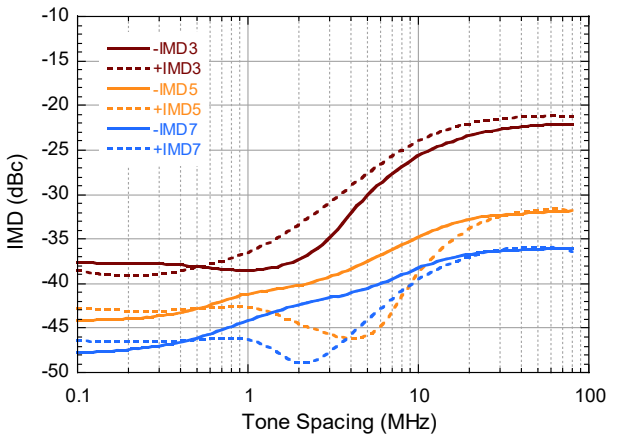

**Quiescent  $V_{GS}$  vs. Temperature**

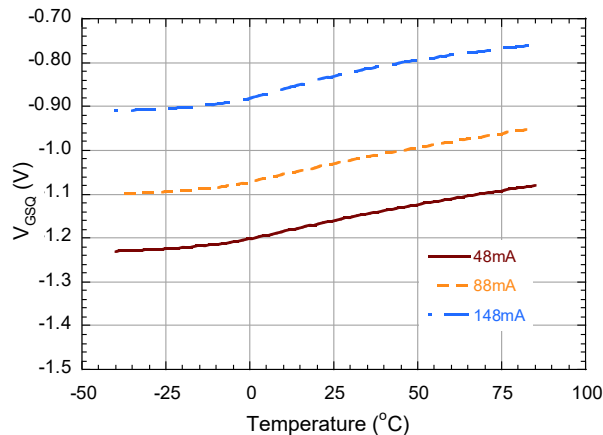

# GaN Amplifier 28 V, 5 W 20 - 2700 MHz



**NPA1008**

Rev. V5

## Lead-Free 4 mm 24-Lead QFN Plastic Package†

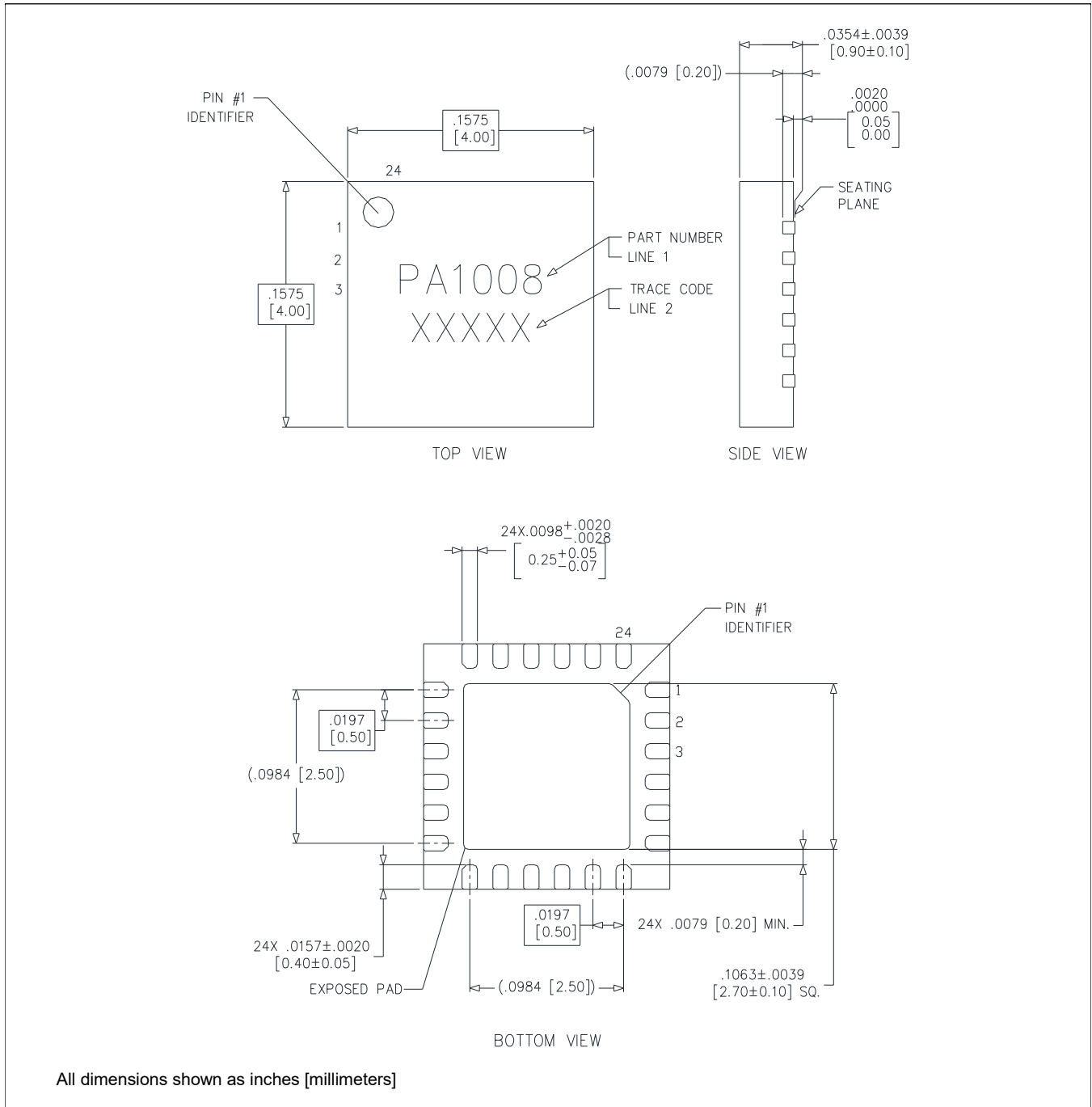

All dimensions shown as inches [millimeters]

† Meets JEDEC moisture sensitivity level 3 requirements.  
Plating is Matte Tin.

# GaN Amplifier 28 V, 5 W 20 - 2700 MHz



**NPA1008**

Rev. V5

MACOM Technology Solutions Inc. ("MACOM"). All rights reserved.

These materials are provided in connection with MACOM's products as a service to its customers and may be used for informational purposes only. Except as provided in its Terms and Conditions of Sale or any separate agreement, MACOM assumes no liability or responsibility whatsoever, including for (i) errors or omissions in these materials; (ii) failure to update these materials; or (iii) conflicts or incompatibilities arising from future changes to specifications and product descriptions, which MACOM may make at any time, without notice. These materials grant no license, express or implied, to any intellectual property rights.

THESE MATERIALS ARE PROVIDED "AS IS" WITH NO WARRANTY OR LIABILITY, EXPRESS OR IMPLIED, RELATING TO SALE AND/OR USE OF MACOM PRODUCTS INCLUDING FITNESS FOR A PARTICULAR PURPOSE, MERCHANTABILITY, INFRINGEMENT OF INTELLECTUAL PROPERTY RIGHT, ACCURACY OR COMPLETENESS, OR SPECIAL, INDIRECT, INCIDENTAL, OR CONSEQUENTIAL DAMAGES WHICH MAY RESULT FROM USE OF THESE MATERIALS.

MACOM products are not intended for use in medical, lifesaving or life sustaining applications. MACOM customers using or selling MACOM products for use in such applications do so at their own risk and agree to fully indemnify MACOM for any damages resulting from such improper use or sale.

## X-ON Electronics

Largest Supplier of Electrical and Electronic Components

*Click to view similar products for [RF Amplifier](#) category:*

*Click to view products by [MACOM](#) manufacturer:*

Other Similar products are found below :

[A82-1](#) [BGA622H6820XTSA1](#) [BGA 728L7 E6327](#) [BGB719N7ESDE6327XTMA1](#) [HMC397-SX](#) [HMC405](#) [HMC561-SX](#) [HMC8120-SX](#)  
[HMC8121-SX](#) [HMC-ALH382-SX](#) [HMC-ALH476-SX](#) [SE2433T-R](#) [SMA3101-TL-E](#) [SMA39](#) [A66-1](#) [A66-3](#) [A67-1](#) [LX5535LQ](#) [LX5540LL](#)  
[MAAM02350](#) [HMC3653LP3BETR](#) [HMC549MS8GETR](#) [HMC-ALH435-SX](#) [SMA101](#) [SMA32](#) [SMA411](#) [SMA531](#) [SST12LP17E-XX8E](#)  
[SST12LP19E-QX6E](#) [WPM0510A](#) [HMC5929LS6TR](#) [HMC5879LS7TR](#) [HMC1126](#) [HMC1087F10](#) [HMC1086](#) [HMC1016](#) [SMA1212](#)  
[MAX2689EWS+T](#) [MAAMSS0041TR](#) [MAAM37000-A1G](#) [LTC6430AIUF-15#PBF](#) [CHA5115-QDG](#) [SMA70-2](#) [SMA4011](#) [A231](#) [HMC-](#)  
[AUH232](#) [LX5511LQ](#) [LX5511LQ-TR](#) [HMC7441-SX](#) [HMC-ALH310](#)