

GaN Power Amplifier, 28 V, 125 W 2.1 - 2.7 GHz



NPT25100

Rev. V1

Features

- GaN on Si HEMT D-Mode Power Amplifier
- Suitable for Linear & Saturated Applications
- Broadband Operation from 2.1 - 2.7 GHz
- 125 W P3dB Peak Envelope Power
- 90 W P3dB CW Power
- 10 W Linear Power @ 2% EVM for Single Carrier OFDM, 10.3 dB peak/avg., 10 MHz channel bandwidth
- 16.5 dB Gain
- 26% Efficiency
- Characterized for Operation up to 32 V
- 100% RF Tested
- Thermally Enhanced Industry Standard Package
- High Reliability Gold Metallization Process
- RoHS* Compliant

Applications

- Defense Communications
- Land Mobile Radio
- Avionics
- Wireless Infrastructure
- ISM
- VHF/UHF/L/S-Band Radar

Description

The NPT25100 GaN on silicon HEMT D-Mode amplifier optimized for 2.1 - 2.7 GHz operation. This device supports CW, pulsed, and linear operation with output power levels to 125 W in an industry standard plastic package with bolt down flange.

NPT25100B



NPT25100P



Ordering Information

Part Number	Package
NPT25100B	Standard Flange
NPT25100P	Earless Flange

RF Specifications (CW)¹: Freq: = 2500 MHz, V_{DS} = 28 V, I_{DQ} = 60 mA, T_C = 25°C

Parameter	Test Conditions	Symbol	Min.	Typ.	Max.	Units
Average Output Power	3 dB Gain Compression	P _{3dB}	80	90	—	W
Small Signal Gain	—	G _{SS}	14.0	16.5	—	dB
Drain Efficiency	3 dB Gain Compression	η	55	62	—	%

1. Measured in test fixture.

* Restrictions on Hazardous Substances, compliant to current RoHS EU directive.

MACOM Technology Solutions Inc. (MACOM) and its affiliates reserve the right to make changes to the product(s) or information contained herein without notice. Visit www.macom.com for additional data sheets and product information.

For further information and support please visit:
<https://www.macom.com/support>

DC-0008204

GaN Power Amplifier, 28 V, 125 W

2.1 - 2.7 GHz



NPT25100

Rev. V1

Typical 2-Tone Performance²:

Freq. = 2500 MHz, $V_{DS} = 28$ V, $I_{DQ} = 600$ mA, Tone spacing = 1 MHz, $T_C = 25^\circ\text{C}$

Parameter	Test Conditions	Symbol	Min.	Typ.	Max.	Units
Peak Envelope Power	3 dB Gain Compression 1 dB Gain Compression -35 dB Gain Compression	$P_{3dB,PEP}$ $P_{1dB,PEP}$ P_{IMD3}	—	125 90 80	—	W

2. Measured in Load Pull System (Refer to Table 1 and Figure 1).

Typical OFDM Performance:

Freq. = 2500 - 2700 MHz, $V_{DS} = 28$ V, $I_{DQ} = 600$ mA, $P_{OUT}/\text{Avg.} = 10$ W, $T_C = 25^\circ\text{C}$

Single carrier OFDM waveform 64-QAM 3/4, 8 burst, continuous frame data, 10 MHz channel bandwidth.
Peak/Avg = 10.3 dB @ 0.01% probability on CCDF.

Parameter	Test Conditions	Symbol	Min.	Typ.	Max.	Units
Power Gain	—	G_P	—	16.5	—	dB
Drain Efficiency	—	η	—	26.0	—	%
Error Vector Magnitude	—	EVM	—	2.0	—	%

DC Electrical Characteristics: $T_A = 25^\circ\text{C}$

Parameter	Test Conditions	Symbol	Min.	Typ.	Max.	Units
Off Characteristics						
Drain Source Breakdown Voltage	$V_{GS} = -8$ V, $I_D = 36$ mA	V_{BDS}	100	—	—	V
Drain Source Leakage Current	$V_{GS} = -8$ V, $V_{DS} = 60$ V	I_{DLK}	—	9	18	mA
On Characteristics						
Gate Threshold Voltage	$V_{DS} = 28$ V, $I_D = 36$ mA	V_T	-2.3	-1.8	-1.3	V
Gate Quiescent Voltage	$V_{DS} = 28$ V, $I_D = 70$ mA	V_{GSQ}	-2.0	-1.5	-1.0	V
On Resistance	$V_{GS} = 2$ V, $I_D = 270$ mA	R_{ON}	—	0.13	0.14	Ω
Drain Current	$V_{DS} = 7$ V pulsed, 300 μs pulse width, 0.2% duty cycle	$I_{D,MAX}$	—	21.0	—	A

Absolute Maximum Ratings^{3,4,5}

Parameter	Absolute Maximum
Drain Source Voltage, V_{DS}	100 V
Gate Source Voltage, V_{GS}	-10 V to +3 V
Gate Current, I_G	180 mA
Total Power Dissipation, P_T	100 W
Junction Temperature, T_J	+200°C
Operating Temperature	-40°C to +85°C
Storage Temperature	-65°C to +150°C

3. Exceeding any one or combination of these limits may cause permanent damage to this device.
4. MACOM does not recommend sustained operation near these survivability limits.
5. Operating at nominal conditions with $T_J \leq 200^\circ\text{C}$ will ensure $\text{MTTF} > 1 \times 10^6$ hours.

Thermal Characteristics⁶

Parameter	Test Conditions	Symbol	Typical	Units
Thermal Resistance	$V_{DS} = 48 \text{ V}, T_J = 145^\circ\text{C}$	$R_{\theta JC}$	1.75	°C/W

6. Junction temperature (T_J) measured using IR Microscopy. Case temperature measured using thermocouple embedded in heat-sink.

Handling Procedures

Please observe the following precautions to avoid damage:

Static Sensitivity

Gallium Nitride Circuits are sensitive to electrostatic discharge (ESD) and can be damaged by static electricity. Proper ESD control techniques should be used when handling these HBM (>2000 V), MM (>100 V) Class 1B devices.

GaN Power Amplifier, 28 V, 125 W

2.1 - 2.7 GHz



NPT25100
Rev. V1

Load-Pull Performance: $V_{DS} = 48\text{ V}$, $I_{DQ} = 600\text{ mA}$, $T_C = 25^\circ\text{C}$
Reference Plane at Device Leads, CW Drain Efficiency and Output Power Tradeoff Impedance

Frequency (MHz)	$Z_S (\Omega)$	$Z_L (\Omega)$
2140	12.1 - j20.0	2.6 - j2.6
2300	10.0 - j3.0	2.5 - j2.3
2400	9.5 - j3.0	2.5 - j2.5
2500	9.0 - j3.0	2.5 - j2.7
2600	8.5 - j3.0	2.5 - j3.1
2700	8.0 - j3.0	2.5 - j3.3

Impedance Reference

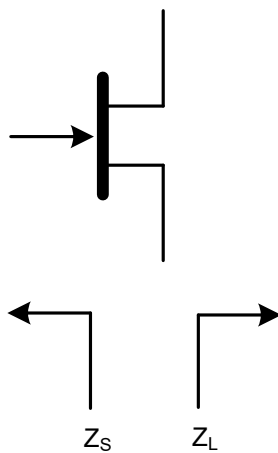

Z_S is the source impedance presented to the device.
 Z_L is the load impedance presented to the device.

Z_S and Z_L vs. Frequency

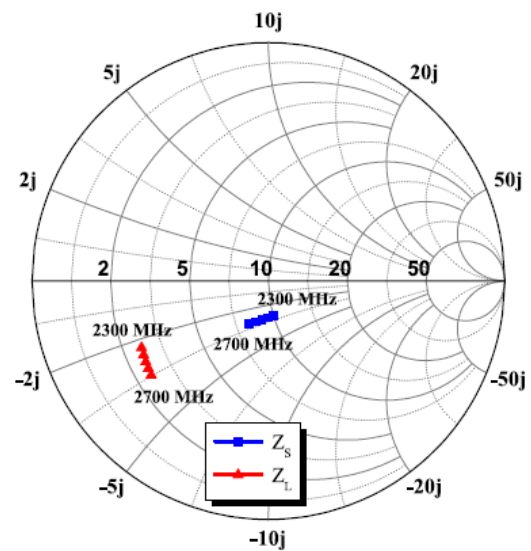
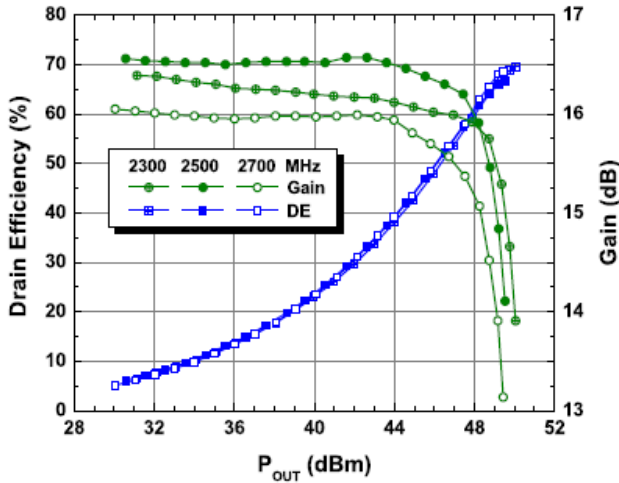

Figure 1 - Optimal impedance for CW performance, $V_{DS} = 28\text{ V}$, $I_{DQ} = 600\text{ mA}$.

Typical CW Performance in Loadpull System:

Drain Efficiency & Gain
28 V, 600 mA, 2300 - 2700 MHz



Drain Efficiency & Gain
28 V & 32 V, 600 mA, 2500 MHz

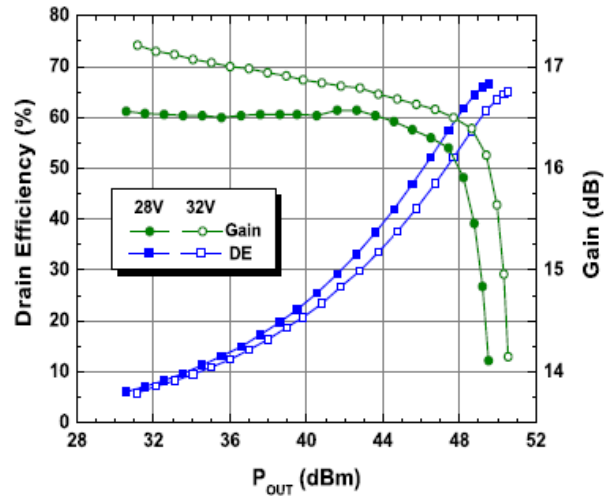

P_{3dB}, Drain Efficiency & Gain
28 V, 600 mA

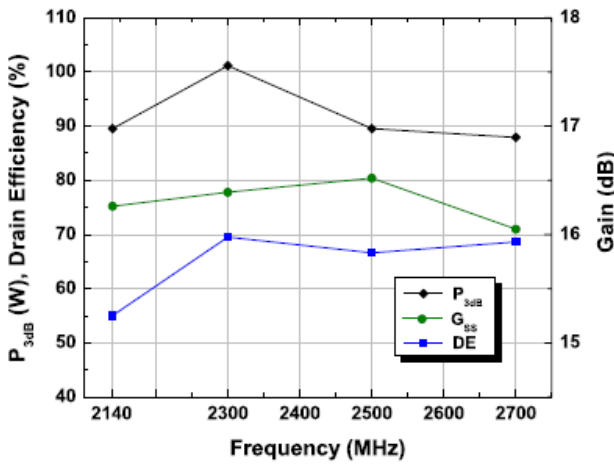

Drain Efficiency & Gain
28 V & 32 V, 600 mA, 2500 MHz, Tone Spacing = 1 MHz

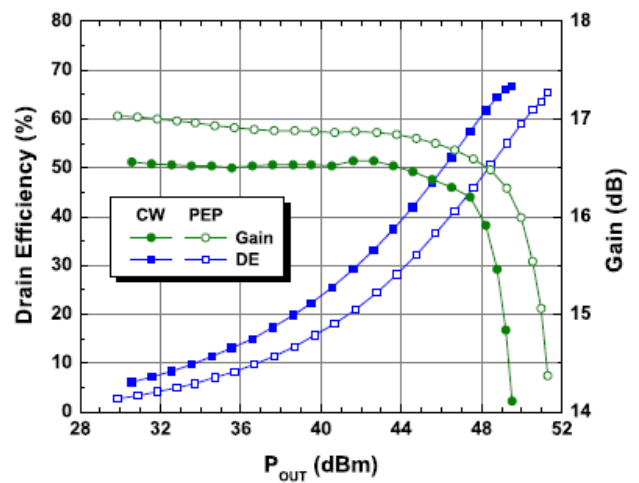

Typical CW Performance in Loadpull System:

Drain Efficiency, Gain, & IMD3
28 V, 600 mA, 2500 MHz, Tone Spacing = 1 MHz

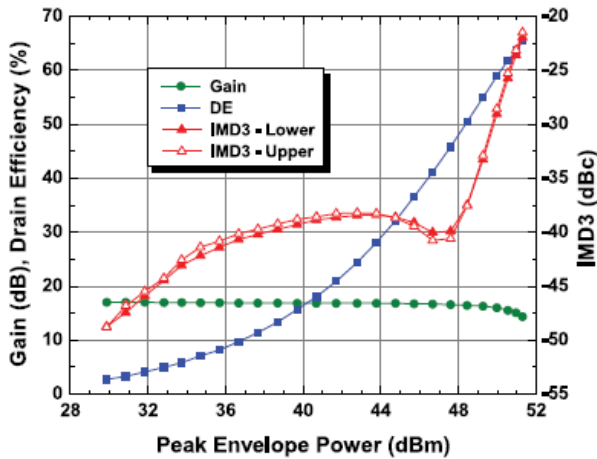

Drain Efficiency, Gain, & IMD3
28 V, 600 mA, 2500 MHz, Tone Spacing = 1 MHz
10 μs Pulse Width, 1% Duty Cycle

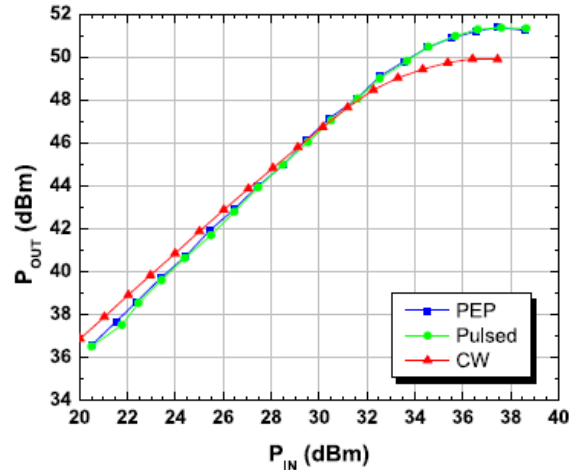

Power
28 V, 600 mA, 2500 MHz, 1% Duty Cycle

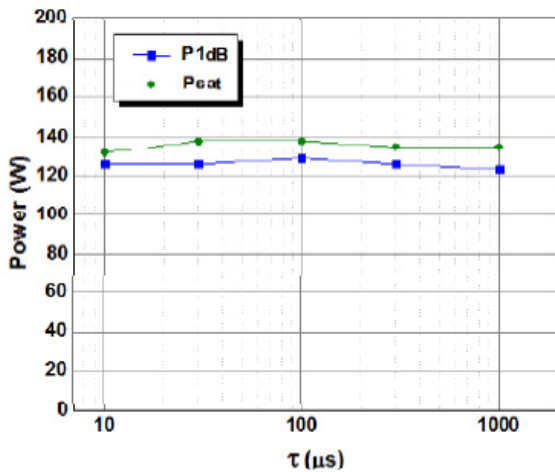

Drain Efficiency, Gain, & EVM
28 V & 32 V, 600 mA, 2500 MHz

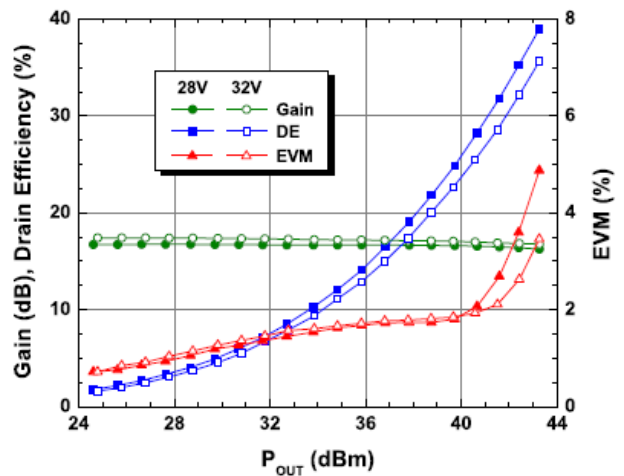

Typical CW Performance in Loadpull System:

Drain Efficiency, Gain, & EVM
28 V & 32 V, 600 mA, 2500 MHz
 $P_{OUT,AVG} = 10\text{ W}$

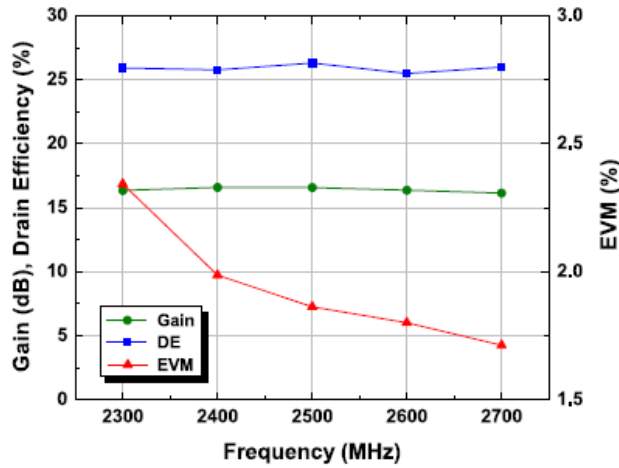

Typical Performance:

Power Derating

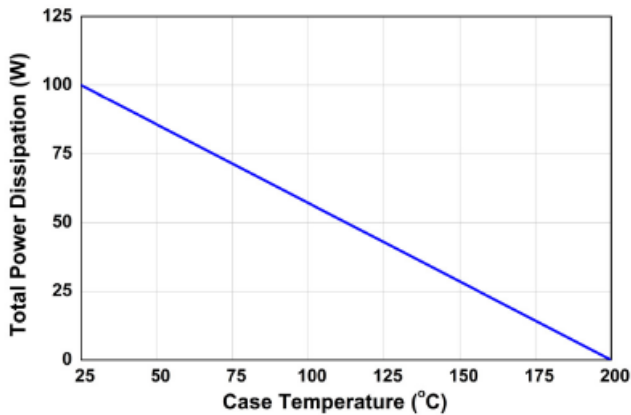

MTTF

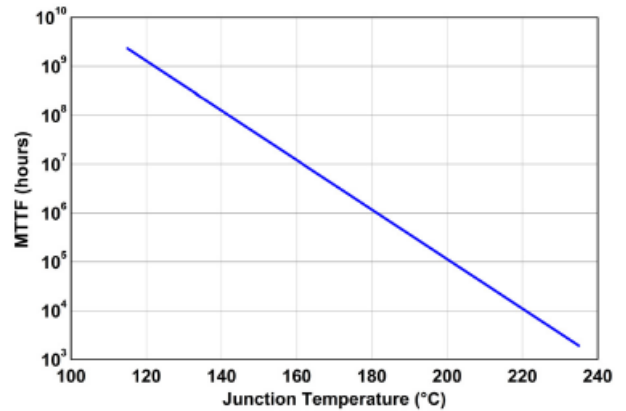

Typical Performance in MACOM Evaluation Circuit:

Drain Efficiency, Gain, & EVM
28 V, 600 mA, 2600 MHz
LTE = 20 MHz

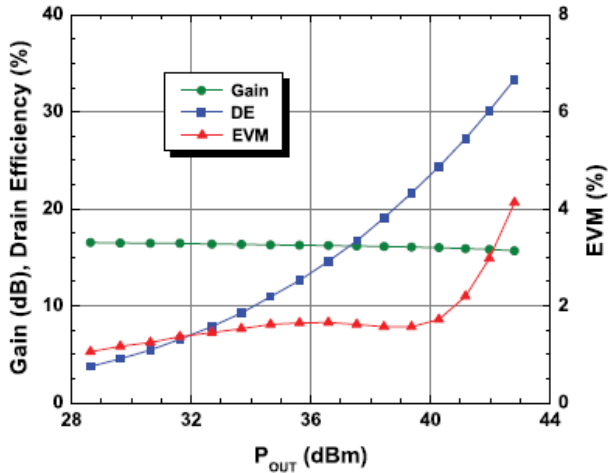

Drain Efficiency, Gain, & EVM
28 V, 600 mA, 2110 - 2170 MHz

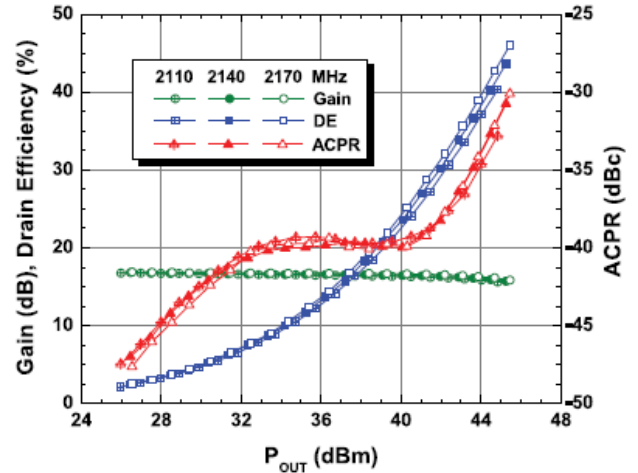

Drain Efficiency & EVM
28 V, 500 - 1000 mA, 2500 MHz

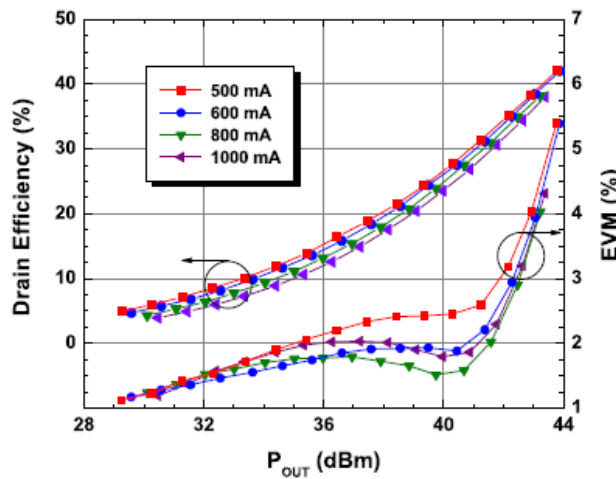

GaN Power Amplifier, 28 V, 125 W 2.1 - 2.7 GHz



NPT25100

Rev. V1

Typical Performance in MACOM Evaluation Circuit:

Gain
28 V, 500 - 1000 mA, 2500 MHz

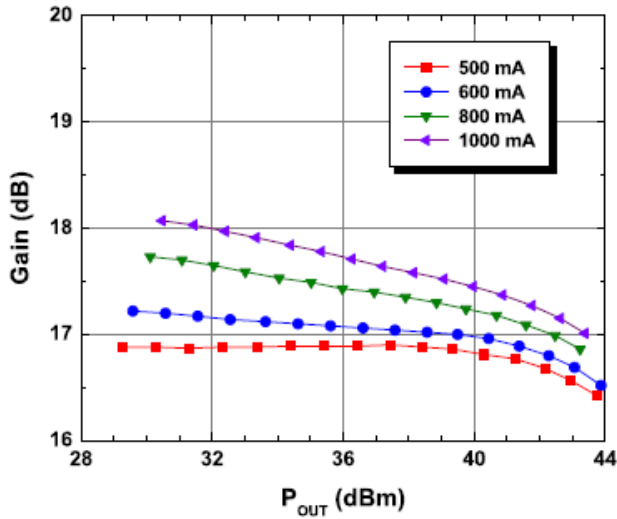

Drain Efficiency, Gain, & EVM
28 V, 600 mA, 2500 MHz

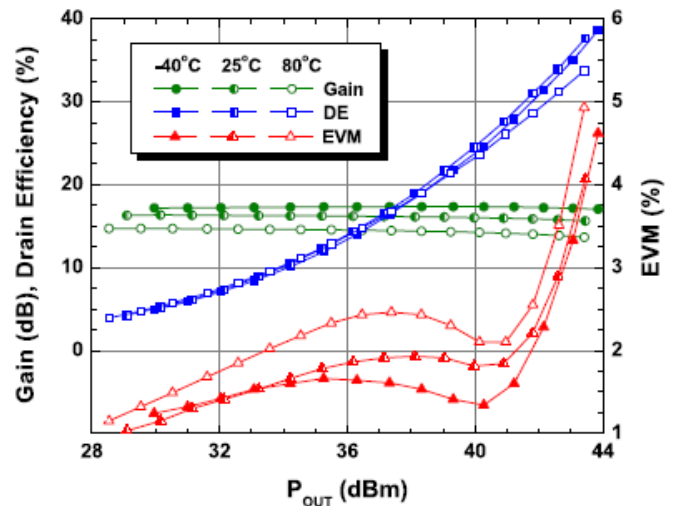

S-Parameters
28 V, 600 mA

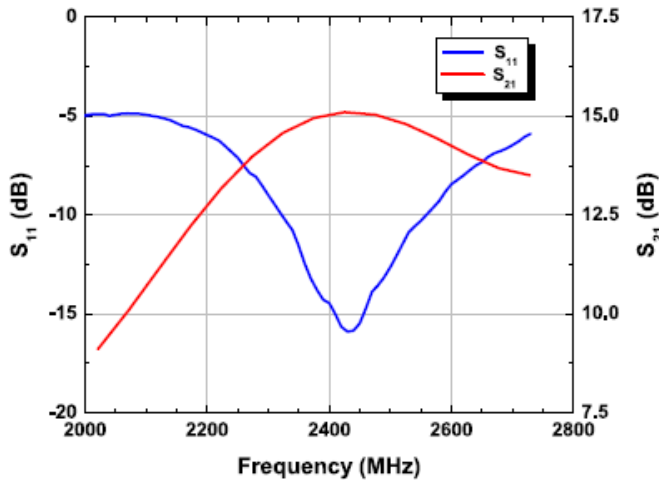

Quiescent Gate Voltage
28 V

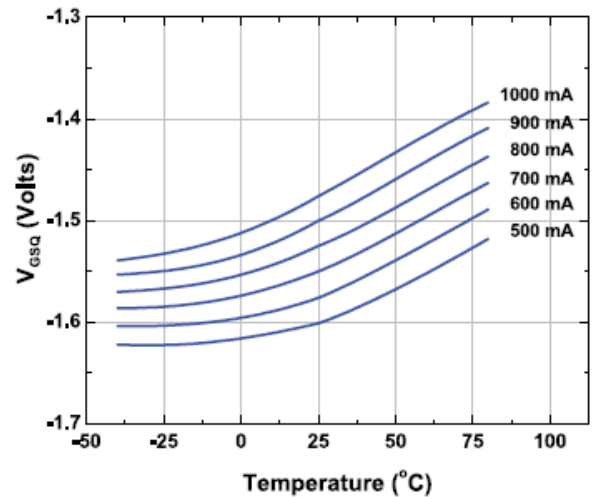

Evaluation Board and Recommended Tuning Solution
2500 MHz Narrowband Circuit

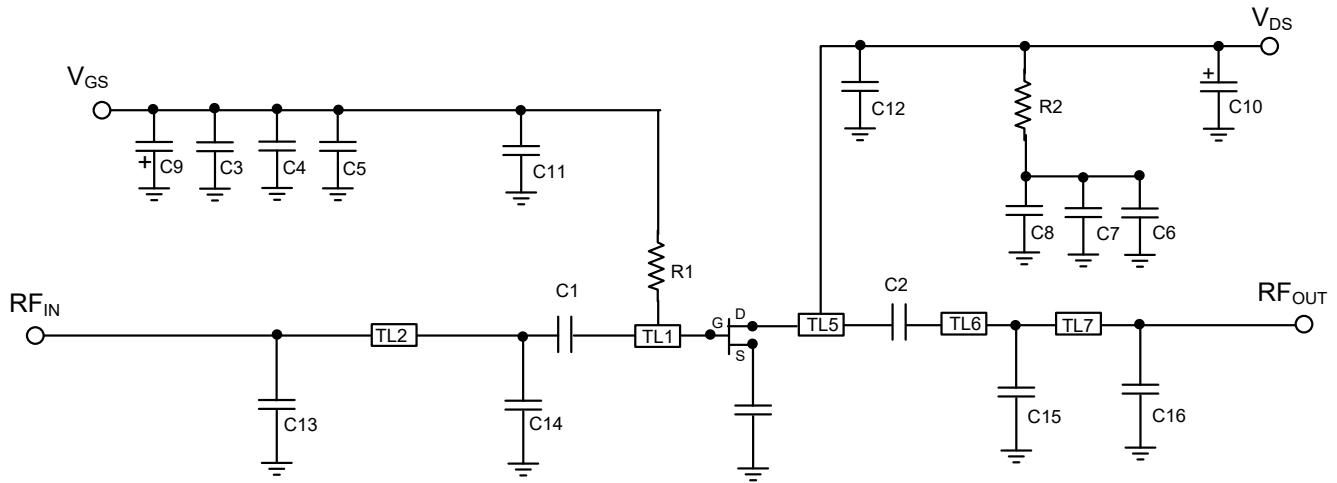

Description

Parts measured on evaluation board (30-mil thick RO4350). The PCB's electrical and thermal ground is provided using a standard-plated densely packed via hole array (see recommended via pattern).

Matching is provided using a combination of lumped elements and transmission lines as shown in the simplified schematic above. Recommended tuning solution component placement, transmission lines, and details are shown on the next page.

Bias Sequencing

Turning the device ON

1. Set V_{GS} to the pinch-off (V_P), typically -5 V.
2. Turn on V_{DS} to nominal voltage (48 V).
3. Increase V_{GS} until the I_{DS} current is reached.
4. Apply RF power to desired level.

Turning the device OFF

1. Turn the RF power off.
2. Decrease V_{GS} down to V_P .
3. Decrease V_{DS} down to 0 V.
4. Turn off V_{GS} .

Evaluation Board and Recommended Tuning Solution
2500 MHz Circuit

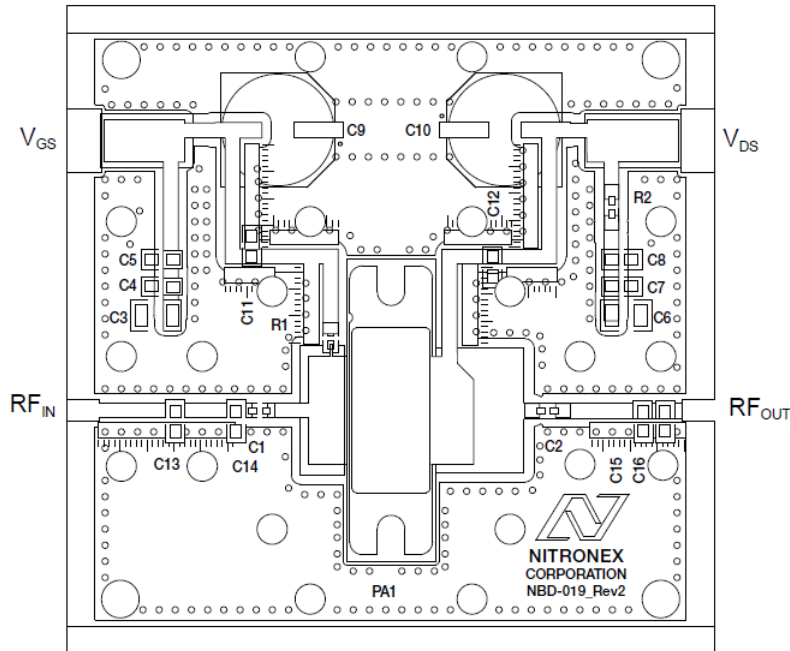

Parts list

Reference	Value	Tolerance	Manufacturer	Part Number
C1	3.3 pF	±0.1 pF	ATC	ATC600F3R3B
C2	1.2 pF	±0.1 pF	ATC	ATC100B1R2BT
C3	1 µF	20%	Panasonic	ECJ-5YB2A105M
C4, C7	0.1 µF	10%	Kemet	C1206C104K1RACTU
C5, C8	0.01 µF	10%	AVX	12061C103KAT2A
C6	1 µF	10%	Panasonic	ECJ-5YB2A105M
C9	150 µF	20%	Nichicon	UPW1C151MED
C10	270 µF	20%	United Chmi-Con	ELXY630ELL271MK25S
C11, C12	33 pF	5%	ATC	ATC600F330B
C13	0.9 pF	±0.1 pF	ATC	ATC600F0R9B
C14	1.8 pF	±0.1 pF	ATC	ATC600F1R8B
C15	Do Not Place	—	—	—
C16	0.8 pF	±0.1 pF	ATC	ATC600F0R8B
PA1	—	—	MACOM	NPT25100B
R1	10 Ω	1%	Panasonic	ERJ-2RKF10R0X
R2	0.033 Ω	5%	Coilcraft	ERJ-6RQFR33V
NBD-019_Rev2	—	—	Alberta Printed Circuits	NBD-019_Rev2
PCB	Rogers RO4350, $\epsilon_r=3.5$, 30 mil			

Outline Drawing NPT25100B†

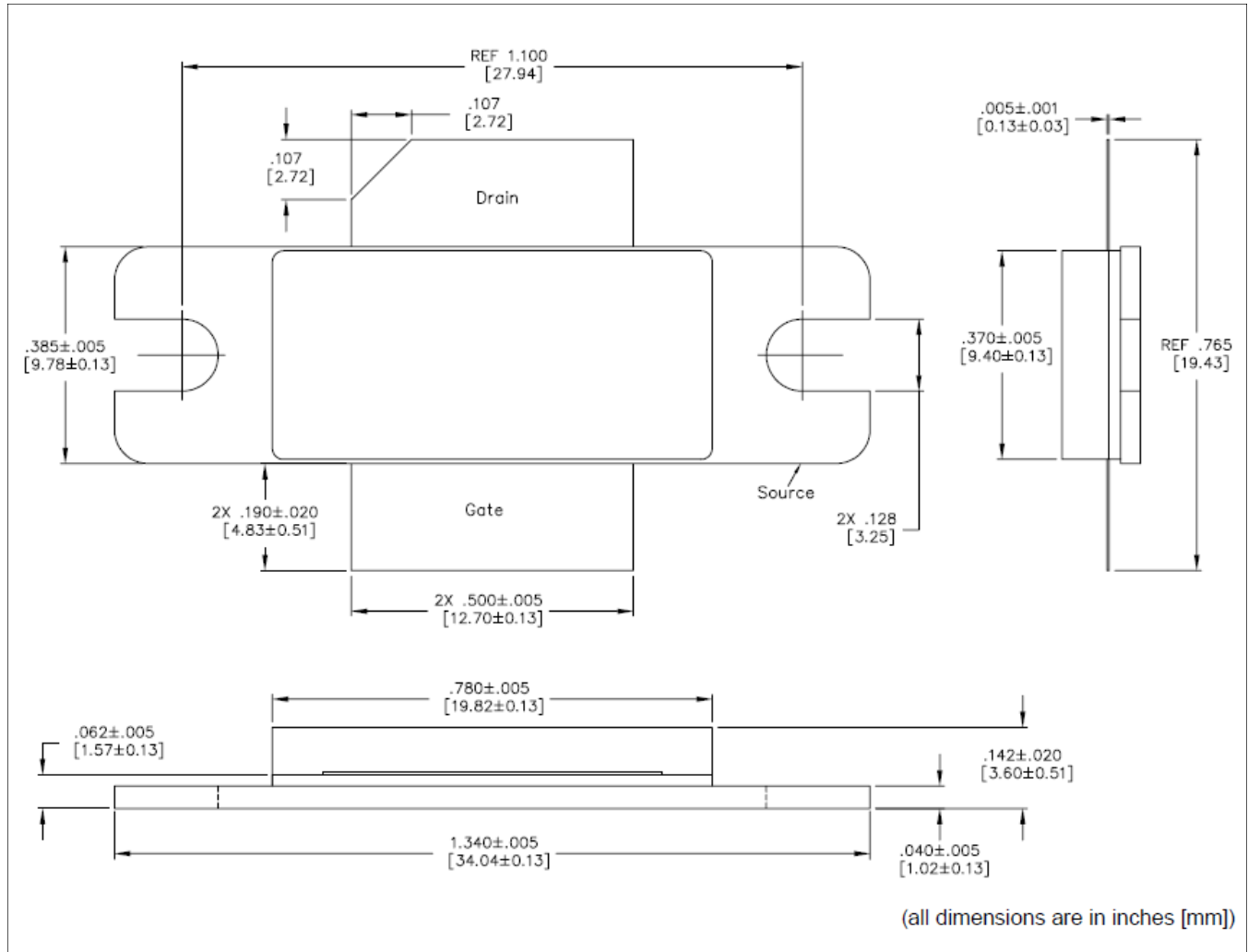

† Reference Application Note AN3025 for mounting/soldering recommendations.
Meets JEDEC moisture sensitivity level 1 requirements.
Plating is Ni/Au.

GaN Power Amplifier, 28 V, 125 W
2.1 - 2.7 GHz



NPT25100
Rev. V1

Outline Drawing NPT25100P†

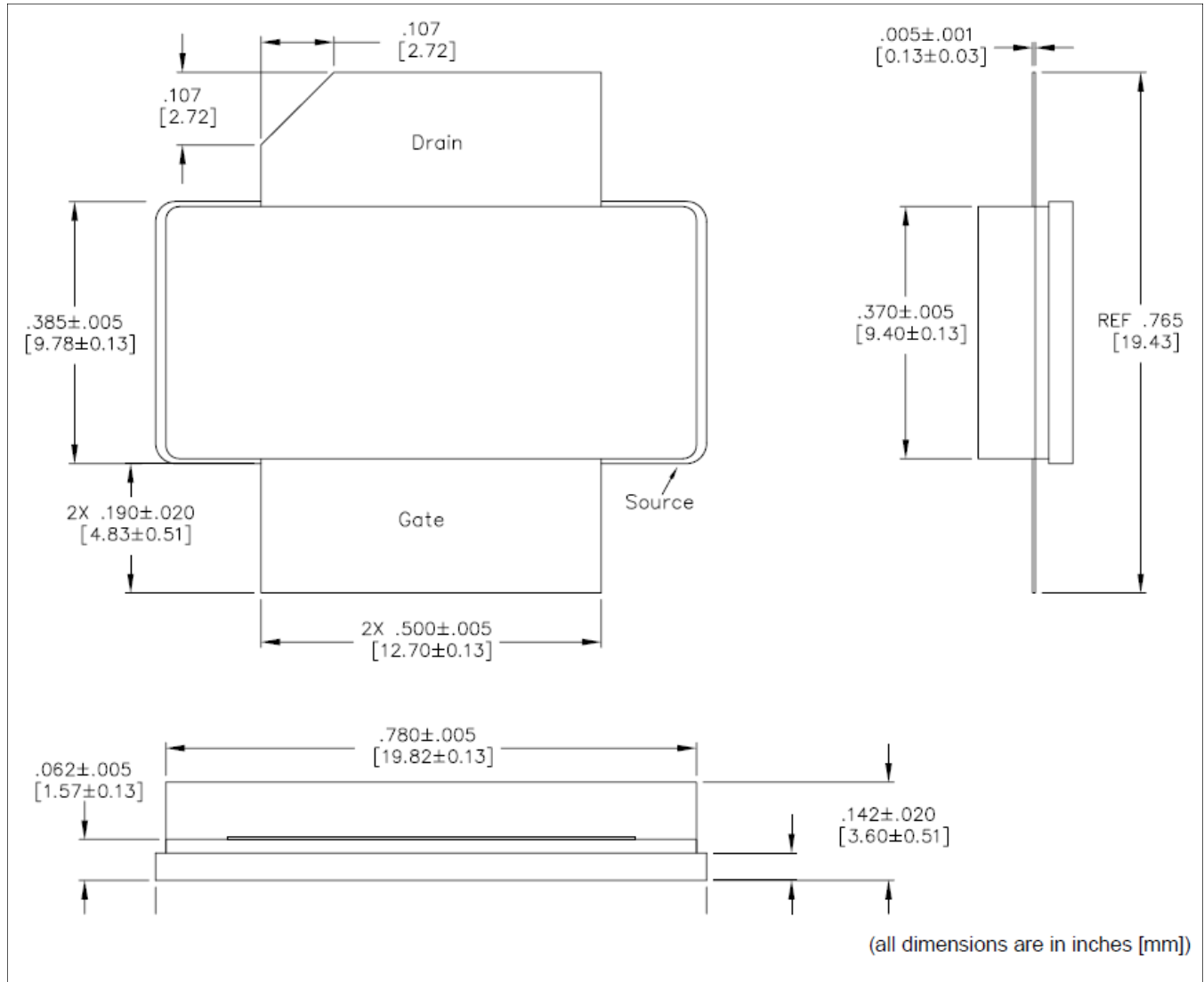

† Reference Application Note AN3025 for mounting/soldering recommendations.
Meets JEDEC moisture sensitivity level 1 requirements.
Plating is Ni/Au.

MACOM Technology Solutions Inc. ("MACOM"). All rights reserved.

These materials are provided in connection with MACOM's products as a service to its customers and may be used for informational purposes only. Except as provided in its Terms and Conditions of Sale or any separate agreement, MACOM assumes no liability or responsibility whatsoever, including for (i) errors or omissions in these materials; (ii) failure to update these materials; or (iii) conflicts or incompatibilities arising from future changes to specifications and product descriptions, which MACOM may make at any time, without notice. These materials grant no license, express or implied, to any intellectual property rights.

THESE MATERIALS ARE PROVIDED "AS IS" WITH NO WARRANTY OR LIABILITY, EXPRESS OR IMPLIED, RELATING TO SALE AND/OR USE OF MACOM PRODUCTS INCLUDING FITNESS FOR A PARTICULAR PURPOSE, MERCHANTABILITY, INFRINGEMENT OF INTELLECTUAL PROPERTY RIGHT, ACCURACY OR COMPLETENESS, OR SPECIAL, INDIRECT, INCIDENTAL, OR CONSEQUENTIAL DAMAGES WHICH MAY RESULT FROM USE OF THESE MATERIALS.

MACOM products are not intended for use in medical, lifesaving or life sustaining applications. MACOM customers using or selling MACOM products for use in such applications do so at their own risk and agree to fully indemnify MACOM for any damages resulting from such improper use or sale.

X-ON Electronics

Largest Supplier of Electrical and Electronic Components

Click to view similar products for [RF JFET Transistors](#) category:

Click to view products by [MACOM](#) manufacturer:

Other Similar products are found below :

[CE3514M4](#) [CE3514M4-C2](#) [CE3520K3-C1](#) [CE3521M4](#) [CE3521M4-C2](#) [CE3512K2-C1](#) [CE3520K3](#) [CG2H80030D-GP4](#) [TGF2023-2-02](#)
[NPT1004D](#) [MAGX-011086](#) [NPT25015D](#) [JANTXV2N4858](#) [CGHV27015S](#) [NPT2021](#) [NPTB00025B](#) [TGF2965-SM](#) [QPD1009](#) [QPD1010](#)
[2SK3557-6-TB-E](#) [J211_D74Z](#) [NPTB00004A](#) [MMBFJ211](#) [QPD0005TR13](#) [QPD0020](#) [QPD1006](#) [QPD1016](#) [QPD1025L](#) [QPD1029L](#)
[QPD1881L](#) [T2G6001528-Q3](#) [SKY65050-372LF](#) [J304](#) [CGH27015F](#) [CGH27060F](#) [CGH55015F1](#) [CMPA801B030F](#) [GTVA262711FA-V2-R0](#)
[GTVA262701FA-V2-R0](#) [CGH40006S](#) [CGH40010F](#) [CGH40025F](#) [CGH40045F](#) [CGH40120F](#) [CGH40180PP](#) [CGH55015F2](#) [CGH60008D](#)
[CGH60030D](#) [CGHV14500F](#) [CGHV1F006S](#)