

# 3 W Power Amplifier

## 4.0 - 5.9 GHz



XP1044-QL

Rev. V6

### Features

- P<sub>1dB</sub> = 34 dBm
- P<sub>OUT</sub> 26 dBm @ EVM = 2.5% (PAR = 9.17 dB)
- OIP3 = 46 dBm
- Gain = 18.5 dB
- Voltage Supply = 8 V
- Input Internally Matched
- 7 mm Surface Mount Package
- RoHS\* Compliant

### Applications

- Wireless Networking & Communications
- ISM

### Description

The XP1044 is a highly linear 2-stage power amplifier capable of 18.5 dB of gain, 34 dBm of power at 1 dB compression and is housed in an RoHS compliant 7 mm package. The XP1044 provides less than 2.5% EVM at 26 dBm output power with 802.16 OFDM signal and peak to average ratio 9.17 dB. The input and output of the device are internally pre-matched facilitating a simplified input and output match. This product operates off an 8 V voltage supply and requires negative voltage which is used for current control.

The XP1044-QL is specifically designed for WiMAX applications between 4.9 GHz and 5.9 GHz, and the performance can be shifted by adding external matching components to cover applications between 4 GHz and 5 GHz.

### Ordering Information

Part Number	Package
XP1044-QL-0N00	bulk quantity
XP1044-QL-EV1	evaluation module for 4.9 GHz ~ 5.9 GHz
XP1044-QL-EV2	evaluation module for 4.0 GHz ~ 5.0 GHz

### Functional Block Diagram

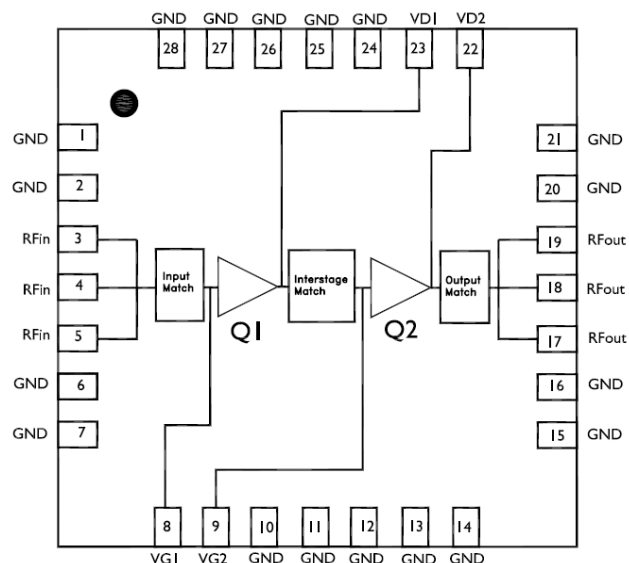

### Pin Configuration

Pin #	Function
1,2,6,7,10,11,12,13,14,15,16,20,21,24,25,26,27,28	Ground
3,4,5	RF Input
8	Gate Voltage1
9	Gate Voltage2
17,18,19	RF Output
23	Drain Voltage1
22	Drain Voltage2

# 3 W Power Amplifier

## 4.0 - 5.9 GHz



XP1044-QL

Rev. V6

### Electrical Specifications: 4.9 - 5.9 GHz (5.8 GHz Typ.), $T_A = 25^\circ\text{C}^1$

Parameter	Units	Min.	Typ.	Max.
Power Gain	dB	16.5	18.5	—
Linear Power (@ EVM = 2.5%, OFDM, 802.16 PAR = 9.17 dB)	dBm	—	26	—
Input Return Loss (S11)	dB	—	-10	—
Output IP3 @ 22 dBm/Tone	dBm	44	46	—
Noise Figure	dB	—	5	—
Output P1dB	dBm	32.5	34.0	—
Supply Current Stage 1 ( $I_{DD1}$ ) Stage 2 ( $I_{DD2}$ )	mA	—	300 600	—
Gate Voltage Stage 1 ( $V_{G1}$ ) Stage 2 ( $V_{G2}$ )	V	-1.2 -1.2	-0.85 -0.85	-0.5 -0.5
Supply Voltage ( $V_{D1}$ & $V_{D2}$ )	V	—	8	—

1. Unless otherwise specified, the following specifications are guaranteed at room temperature in a MACOM test fixture.

### Absolute Maximum Ratings<sup>2,3</sup>

Parameter	Absolute Maximum
Drain Supply Voltage ( $V_D$ )	+9 V
Gate Supply Voltage ( $V_G$ )	0 V ~ -5 V
RF Input Power ( $RF_{IN}$ )	23 dBm
Stage 1 Current ( $I_{DD1}$ )	375 mA
Stage 2 Current ( $I_{DD2}$ )	750 mA
Power Dissipation ( $P_{DISS}$ )	9 W
Storage Temperature	-55°C to +150°C
Junctions Temperature	+175°C
Operating Temperature <sup>4</sup> ( $T_A$ )	-40°C
ESD (HBM)	Class 1A
Moisture Sensitivity Level (MSL)	MSL3
Thermal Resistance <sup>5</sup> ( $R_{TH}$ )	+15.6°C

2. Exceeding any one or combination of these limits may cause permanent damage to this device.

3. MACOM does not recommend sustained operation near these survivability limits.

4. Calculate maximum operating backside temperature using:  $T_{max} = 167^\circ\text{C} - [V_D * I_{DD2} * R_{TH}]$ . Thermal resistance of the 1st stage is  $2x R_{TH}$  of the output stage, and therefore  $I_{DD1}$  must not exceed  $\frac{1}{2} I_{DD2}$  for a specific maximum temperature.

5. Thermal resistance of stage 2 only.

# 3 W Power Amplifier 4.0 - 5.9 GHz



**XP1044-QL**  
Rev. V6

## Evaluation Board Layout (4.9 GHz ~ 5.9 GHz)

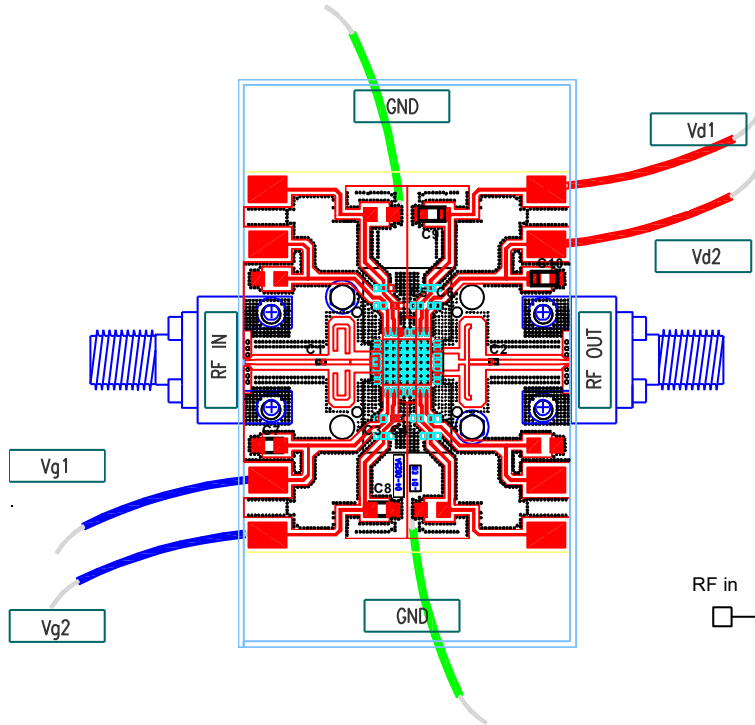

Ref Designator	Description	QTY
C1, C2	10.0 pF 0402 Capacitor	1
C3, C4, C5, C6	1000 pF 0402 Capacitor	4
C7, C8, C9, C10	1 uF A-Case Capacitor	4

Material: Rogers 4003  
Thickness: 8mil

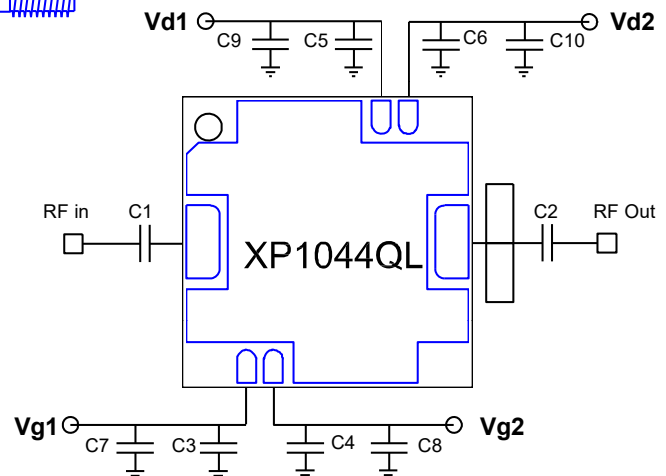

Dimensions are in inches.

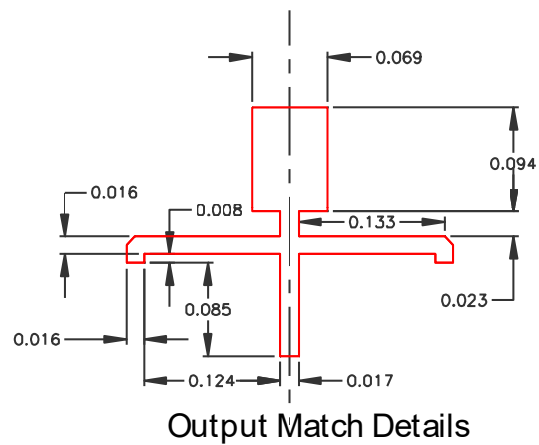
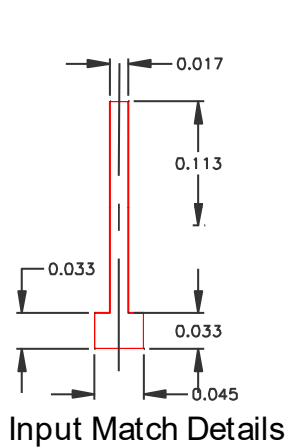

For improved performance at 6 GHz the thick transmission line ( $W = 0.069$ " ) on the output can be extended to touch the two open stubs.

# 3 W Power Amplifier

## 4.0 - 5.9 GHz



XP1044-QL

Rev. V6

### Typical Performance Curves (EV1, $I_{DQ1} = 300\text{ mA}$ , $I_{DQ2} = 600\text{ mA}$ )

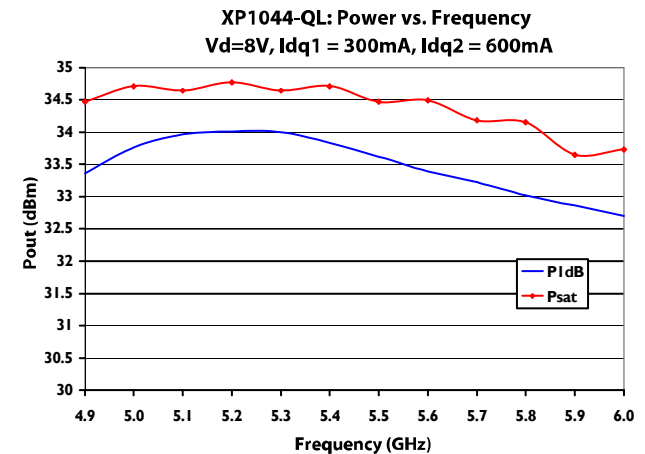
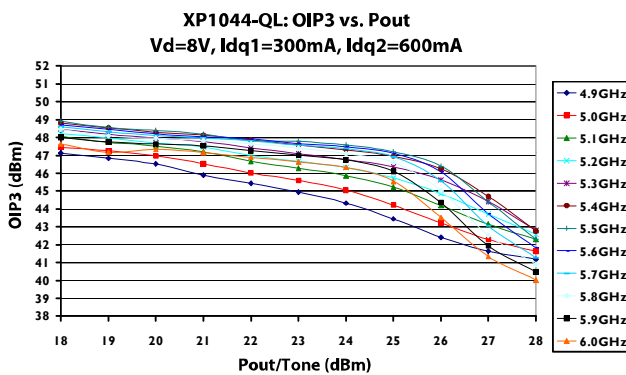
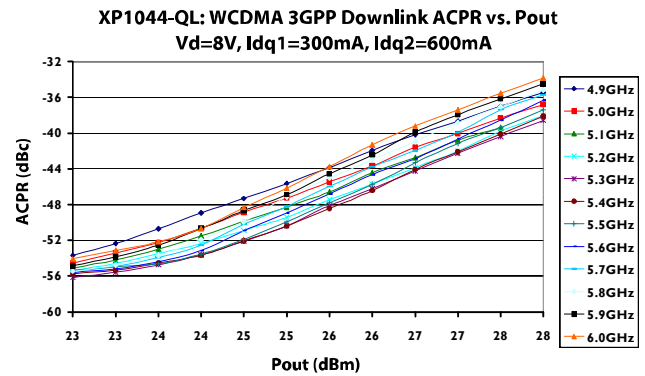
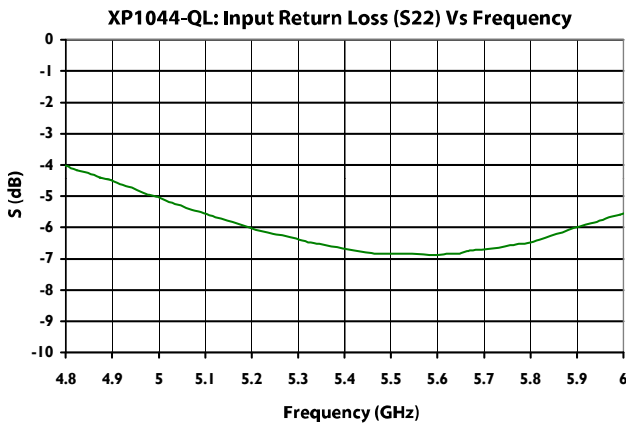
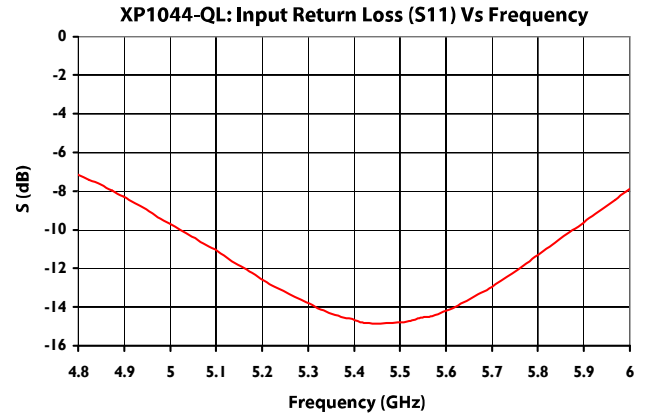
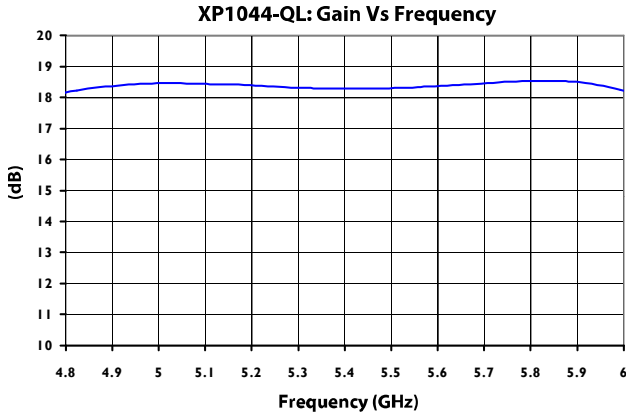

# 3 W Power Amplifier 4.0 - 5.9 GHz



XP1044-QL

Rev. V6

## Typical Performance Curves (EV1, $I_{DQ1} = 300$ mA, $I_{DQ2} = 600$ mA, Over Temp)

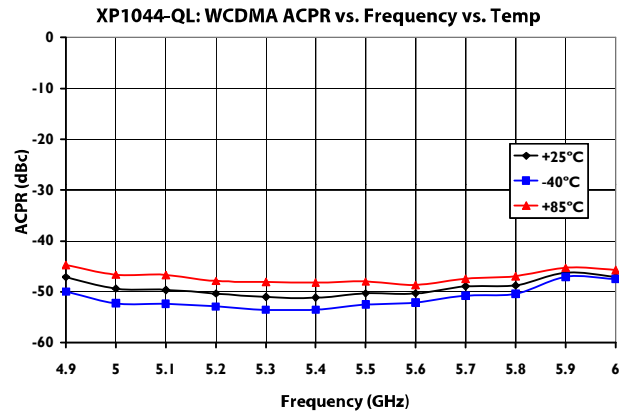
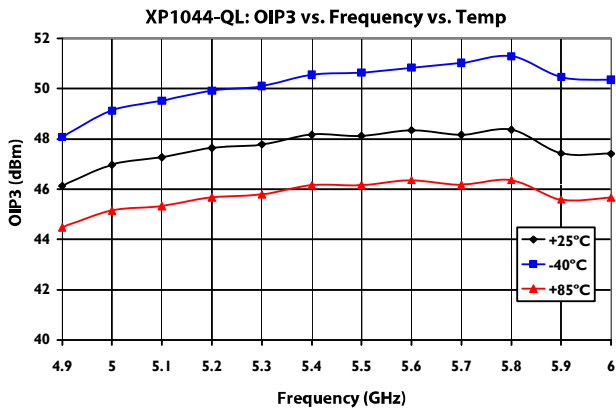
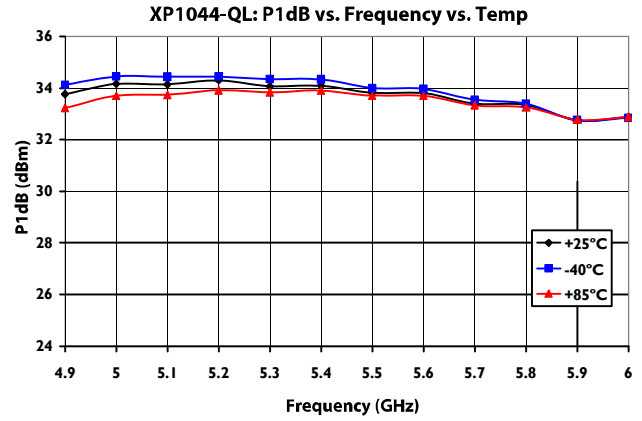
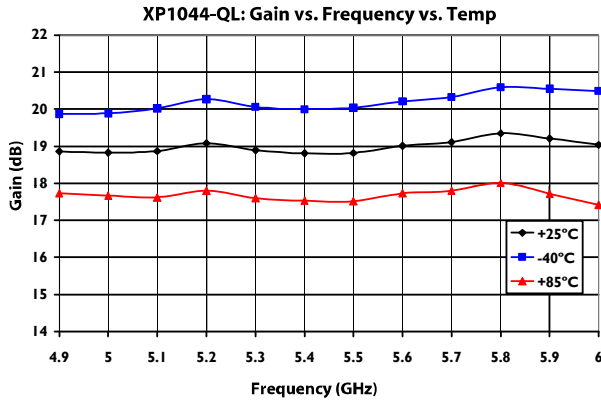

# 3 W Power Amplifier 4.0 - 5.9 GHz



XP1044-QL

Rev. V6

## Typical Performance Curves (EV1, $I_{DQ1} = 330\text{ mA}$ , $I_{DQ2} = 660\text{ mA}$ )

XP1044-QL: P1dB vs. Frequency  
Vd=8V, Idq1=330mA, Idq2=660mA

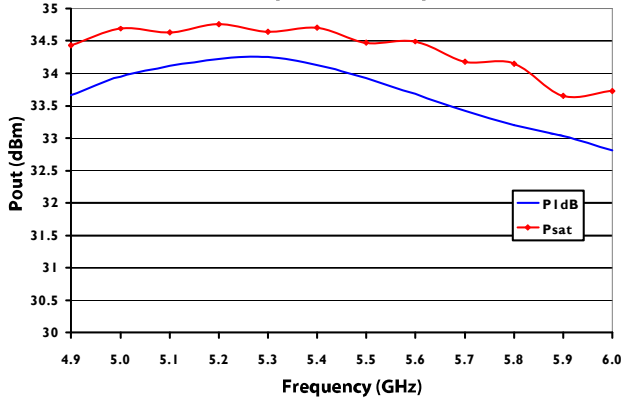

XP1044-QL: WCDMA 3GPP Downlink ACPR vs. Pout  
Vd=8V, Idq1=330mA, Idq2=660mA

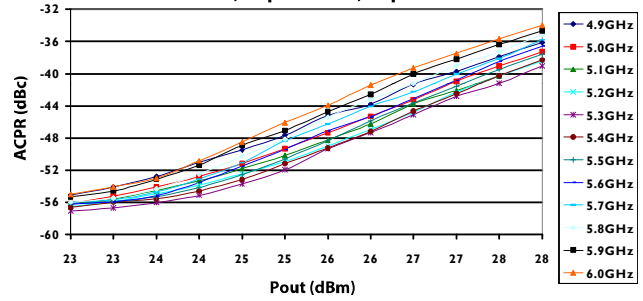

XP1044-QL: OIP3 vs. Pout  
Vd=8V, Idq1=330mA, Idq2=660mA

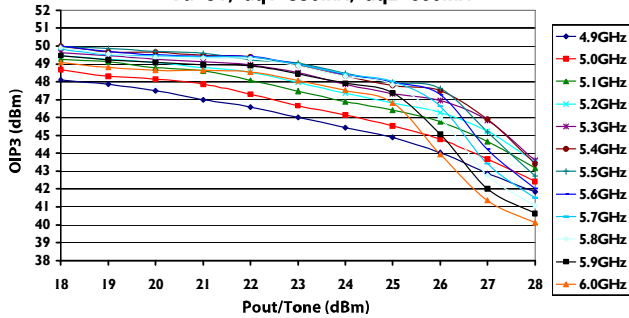

# 3 W Power Amplifier 4.0 - 5.9 GHz



XP1044-QL

Rev. V6

## Evaluation Board Layout: EV2 (4.0 GHz ~ 5.0 GHz)

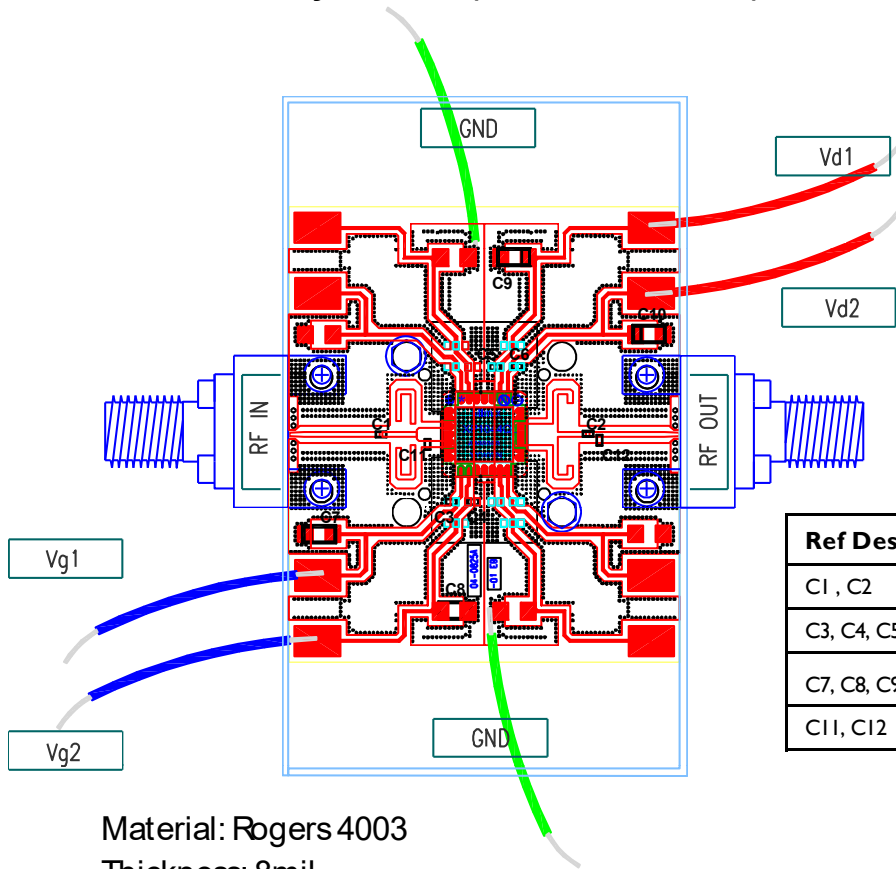

Ref Designator	Description	QTY
C1 , C2	10.0 pF 0402 Capacitor	1
C3, C4, C5, C6	1000 pF 0402 Capacitor	4
C7, C8, C9, C10	1 uF A-Case Capacitor	4
C11, C12	0.5 pF 0402 Capacitor	2

Material: Rogers 4003  
Thickness: 8mil

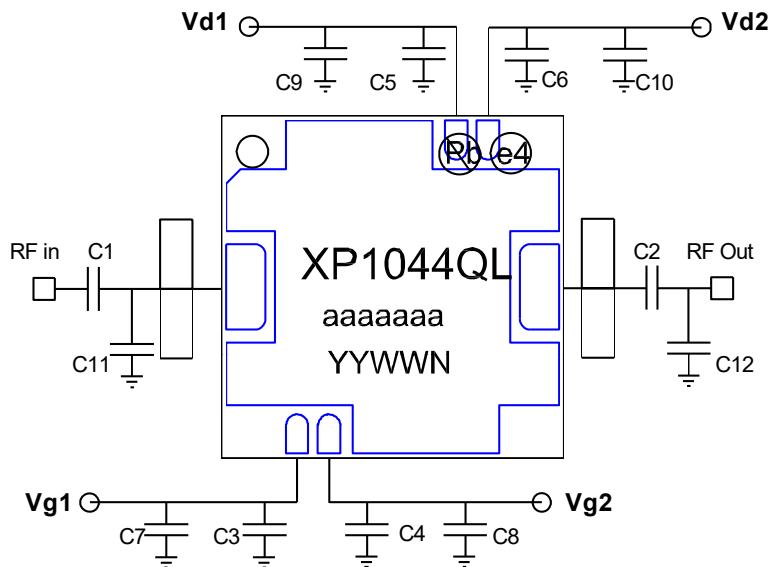

# 3 W Power Amplifier 4.0 - 5.9 GHz



XP1044-QL

Rev. V6

## Typical Performance Curves (EV2, $I_{DQ1} = 300\text{ mA}$ , $I_{DQ2} = 600\text{ mA}$ )

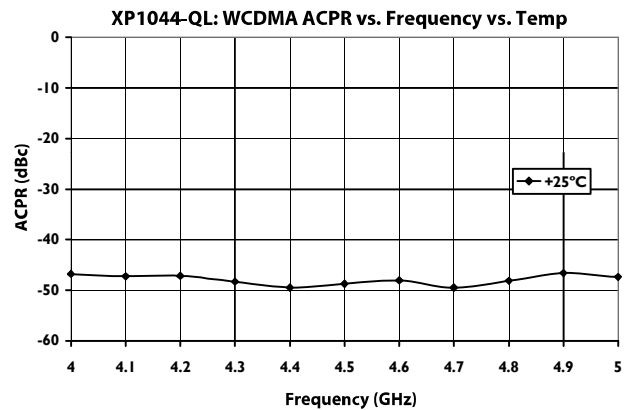
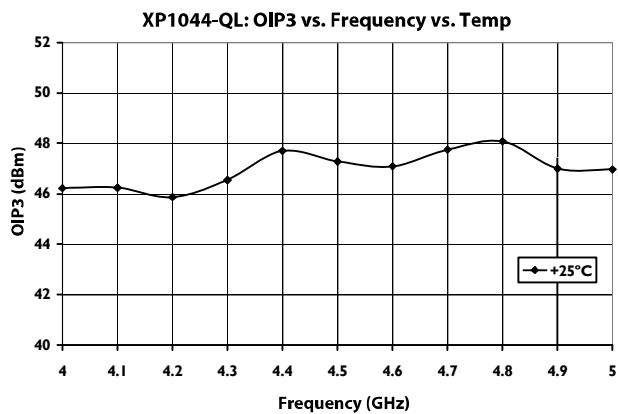
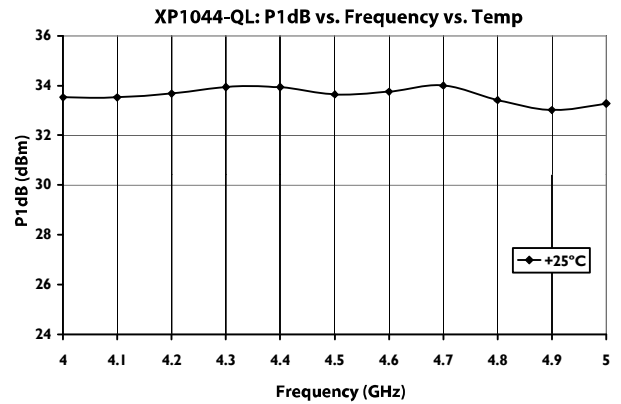
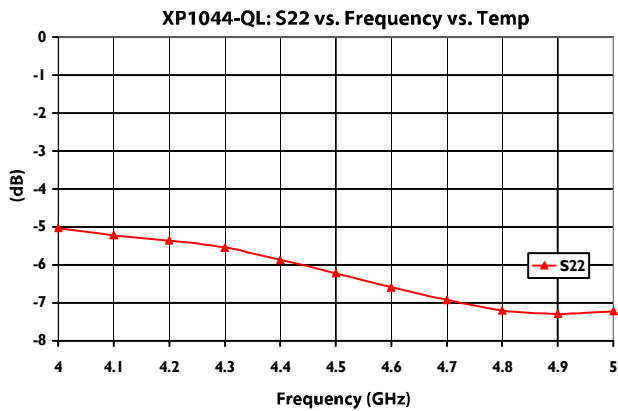
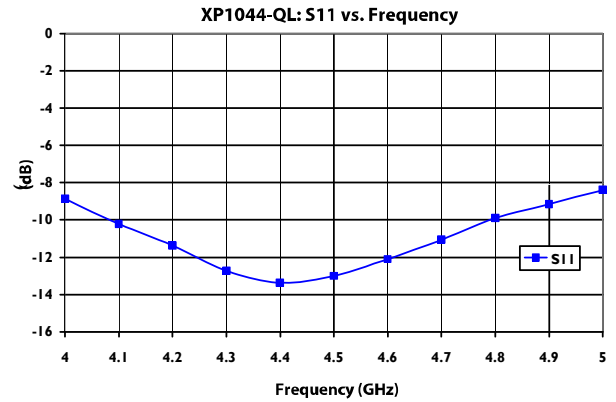
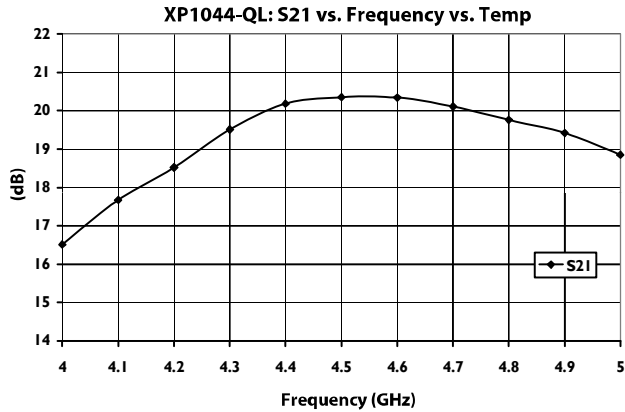



### App Note [1] Biasing -

The XP1044-QL requires power supply sequencing. Negative voltage supply ( $V_G$ ) needs to be turned on first and then positive voltage can be applied to the drain ( $V_D$ ). When turning off the device, the positive supply ( $V_D$ ) should be turned off first and then negative voltage ( $V_G$ ) can be removed.

The gate voltage is adjusted in order to set the drain current to the desired level. The gate voltage required to achieve a certain current can vary over temperature and from one device to another due to pinch-off voltage variation. Constant drain current can be achieved by implementing an active bias circuit which allows for temperature compensation and eliminates the effect of pinch off voltage variation.

The input stage transistor periphery is half of the output stage transistor periphery and therefore the gate voltages needed to set the first stage current to 300 mA and the second stage current to 600 mA are the same. The gate voltages can be connected together and a single active bias circuit can be implemented adding a total of 6 components.

### Handling Procedures

Please observe the following precautions to avoid damage:

### Static Sensitivity

Gallium Arsenide Integrated Circuits are sensitive to electrostatic discharge (ESD) and can be damaged by static electricity. Proper ESD control techniques should be used when handling these class 2 devices.

Lead-Free Package Dimensions/Layout

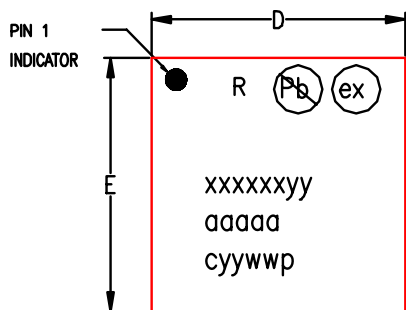

TOP VIEW

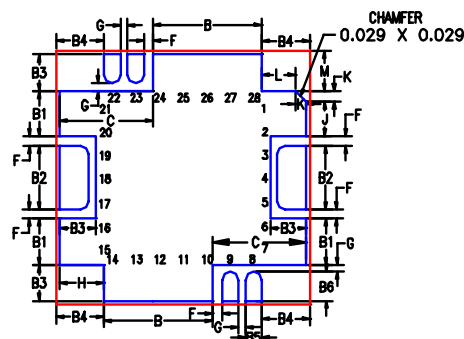
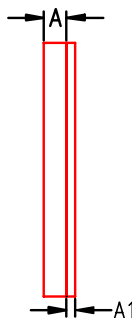

BOTTOM VIEW

Markings:  
Pin 1/BOM Rev/Pb Free Sym  
MACOM Co. Name  
MACOM Part / Model No.  
Wafer Lot Number  
Date Code / Plating

NOTE:  
1. ALL DIMENSIONS ARE IN MM AND INCHES.

	MIN	TYP	MAX	MIN	TYP	MAX
A	0.61	0.66	0.71	0.021	0.026	0.031
A1	—	0.20	—	—	0.008	—
B	0.40	3.00	0.50	0.113	0.118	0.023
B1	1.21	1.26	1.31	0.045	0.050	0.055
B2	1.70	1.75	1.80	0.064	0.069	0.074
B3	0.94	0.99	1.04	0.034	0.039	0.044
B4	1.27	1.32	1.37	0.047	0.052	0.057
B5	0.41	0.46	0.51	0.013	0.018	0.023
B6	0.75	0.80	0.85	0.026	0.031	0.036
C	2.47	2.52	2.57	0.094	0.099	0.104
D	7.00 BSC			0.276		
E	7.00 BSC			0.276		
F	0.20	0.25	0.30	0.005	0.010	0.015
G	0.14	0.19	0.24	0.002	0.007	0.012
H	1.17	1.22	1.27	0.043	0.048	0.053
J	0.92	0.97	1.02	0.033	0.038	0.043
K	0.24	0.29	0.34	0.006	0.011	0.016
L	0.88	0.93	0.97	0.031	0.036	0.041
M	1.05	1.10	1.15	0.038	0.043	0.048

RECOMMENDED SOLDER PAD PITCH AND DIMENSIONS  
DIMENSIONS ARE IN MM [INCHES]

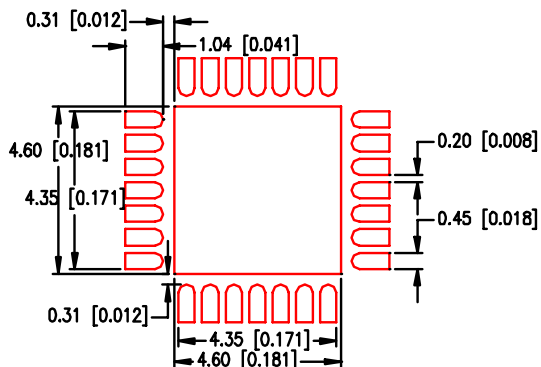

1. VIEWS ARE NOT TO SCALE: USE DIMENSIONS AND TABLE.

MACOM Technology Solutions Inc. ("MACOM"). All rights reserved.

These materials are provided in connection with MACOM's products as a service to its customers and may be used for informational purposes only. Except as provided in its Terms and Conditions of Sale or any separate agreement, MACOM assumes no liability or responsibility whatsoever, including for (i) errors or omissions in these materials; (ii) failure to update these materials; or (iii) conflicts or incompatibilities arising from future changes to specifications and product descriptions, which MACOM may make at any time, without notice. These materials grant no license, express or implied, to any intellectual property rights.

THESE MATERIALS ARE PROVIDED "AS IS" WITH NO WARRANTY OR LIABILITY, EXPRESS OR IMPLIED, RELATING TO SALE AND/OR USE OF MACOM PRODUCTS INCLUDING FITNESS FOR A PARTICULAR PURPOSE, MERCHANTABILITY, INFRINGEMENT OF INTELLECTUAL PROPERTY RIGHT, ACCURACY OR COMPLETENESS, OR SPECIAL, INDIRECT, INCIDENTAL, OR CONSEQUENTIAL DAMAGES WHICH MAY RESULT FROM USE OF THESE MATERIALS.

MACOM products are not intended for use in medical, lifesaving or life sustaining applications. MACOM customers using or selling MACOM products for use in such applications do so at their own risk and agree to fully indemnify MACOM for any damages resulting from such improper use or sale.

## X-ON Electronics

Largest Supplier of Electrical and Electronic Components

*Click to view similar products for [RF Development Tools](#) category:*

*Click to view products by [MACOM](#) manufacturer:*

Other Similar products are found below :

[MAAM-011117](#) [MAAP-015036-DIEEV2](#) [EV1HMC1113LP5](#) [EV1HMC6146BLC5A](#) [EV1HMC637ALP5](#) [122410-HMC686LP4E](#) [ADL5363-EVALZ](#) [130437-HMC1010LP4E](#) [EKIT01-HMC1197LP7F](#) [SKYA21001-EVB](#) [SMP1331-085-EVB](#) [EVAL01-HMC1041LC4](#) [MAAL-011111-000SMB](#) [MAAM-009633-001SMB](#) [107712-HMC369LP3](#) [107780-HMC322ALP4](#) [SP000416870](#) [EV1HMC520ALC4](#) [EV1HMC244AG16](#) [EV1HMC539ALP3](#) [124694-HMC742ALP5](#) [SC20ASATEA-8GB-STD](#) [MAX2692EVKIT#](#) [SKY12343-364LF-EVB](#) [108703-HMC452QS16G](#) [119197-HMC658LP2](#) [EV1HMC647ALP6](#) [ADL5725-EVALZ](#) [106815-HMC441LM1](#) [UXN14M9PE](#) [SIMSA868-DKL](#) [SIMSA868C-DKL](#) [SKY65806-636EK1](#) [SKY68020-11EK1](#) [SKY67159-396EK1](#) [SKY66181-11-EK1](#) [SKY65804-696EK1](#) [SKY13396-397LF-EVB](#) [SKY13380-350LF-EVB](#) [SKY13322-375LF-EVB](#) [SKY12207-478LF-EVB](#) [SE5023L-EK1](#) [SE5004L-EK1](#) [SE2436L-EK1](#) [Se2435L-EK1](#) [SIMSA915C-DKL](#) [SIMSA915-DKL](#) [SIMSA433C-DKL](#) [SKY12211-478LF-EVB](#) [EVK-R202-00B](#)